

ISSUE 5

PARTS & ACCESSORIES FOR YOUR

# MX-5

including technical advice and detailed schematics

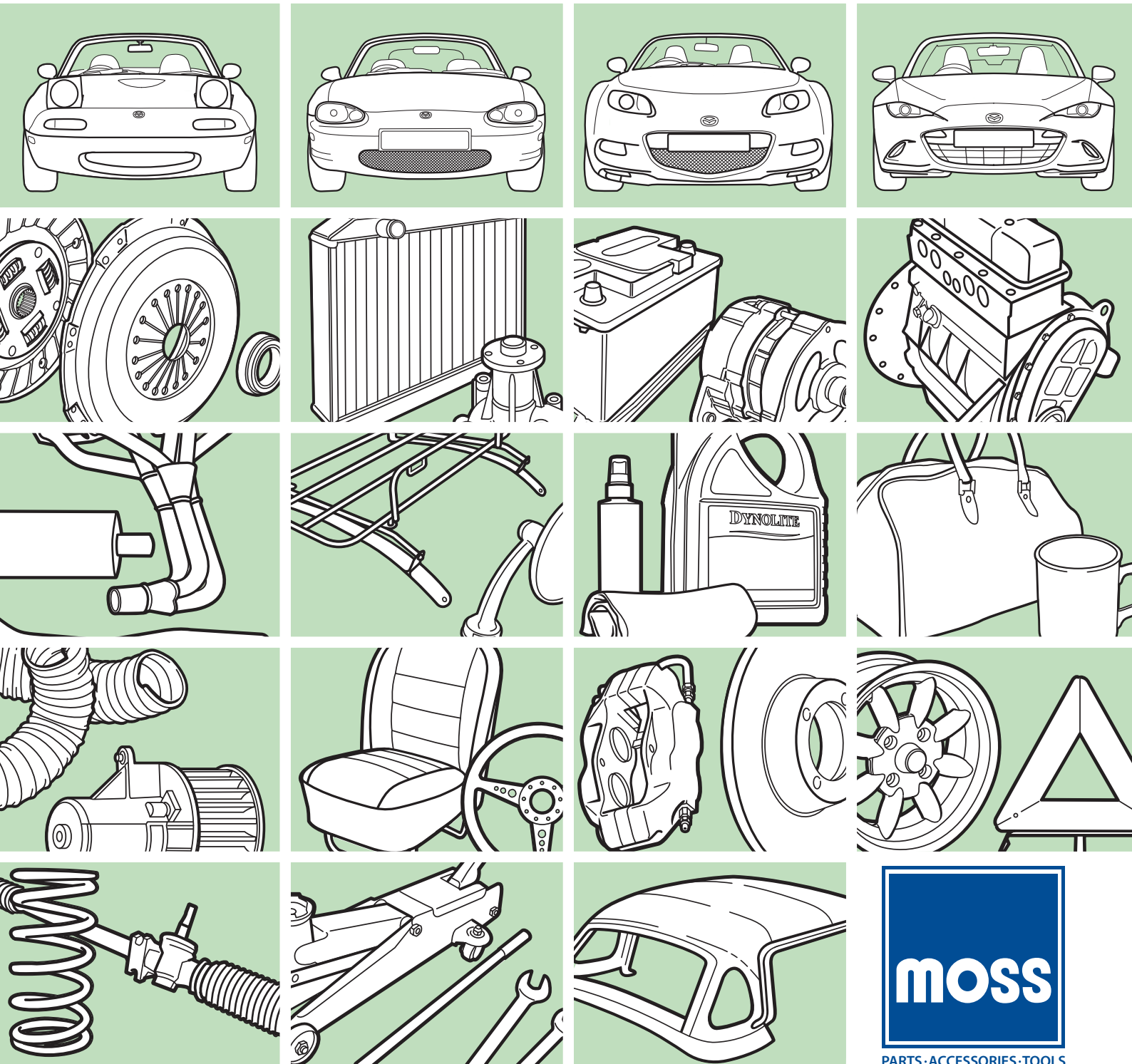

## HOW TO ORDER

### ORDER ONLINE

Ordering online is quick and straight forward. Simply search by part number or browse by model and component categories. Our site features detailed schematics so identifying the correct part is easy, right down to the last nut and bolt. Should you get stuck, our knowledgeable sales staff are ready to help using our live-chat feature.

Add the parts that you need to your basket and head to the checkout for delivery and payment options. Once checked out, you will receive a confirmation of your order via email, by which time your parts will be being picked and packed, ready to be sent to your door.

### ORDER THROUGH A BRANCH

Whether you are visiting, calling or emailing, our knowledgeable branch staff will be happy to help you get the parts that you need. They are car enthusiasts too and understand the challenges that sometimes come with identifying the right parts for rare and classic cars. Of course, the more information about your vehicle that you have to hand, the quicker and easier it will be for us to help.

Arranging to collect parts from our branches is easy, our teams will let you know once your order is ready. Alternatively, they can dispatch your order directly to you.

### PRICING

Due to constant variations of world markets and currency fluctuations the prices in this catalogue are subject to change. We make every attempt to keep prices competitive and stable, however in common with all other suppliers in our industry, we reserve the right to alter prices without prior notice. For the latest prices, please call or visit [moss-europe.co.uk](http://moss-europe.co.uk). All prices are per unit (unless otherwise stated).

Value Added Tax (VAT) at the current UK rate of 20% will be levied on all orders being dispatched to countries within the UK, including Northern Ireland. Shipments to countries outside the UK, including all EU countries, will not be charged VAT. Prices are correct at the time of going to print, postage & packaging is not included. E&OE.

### SHIPPING & DISPATCH

Orders for delivery in the UK may be dispatched by regular post for small/lightweight items, larger items may be dispatched via a courier. Please call us for the best delivery option for your order and the latest delivery prices.

For delivery outside the UK we offer the following services. Economy delivery (by road): 2 to 5 days (approximately). Express delivery (by air): 1 to 2 days (Guaranteed). For small and low value orders we also use airmail. For these services, please ask for prices and the best delivery option when you place your order. Most deliveries (except airmail) are 'trackable', (inc: e-mail updates and internet access for selected carriers). Please remember, all carriage charges are dependent on either gross weight or volumetric weight, whichever is greater. If a quotation is required prior to placing your order, please contact a member of the sales department. Alternatively, you can arrange your own collection.

### ORDERING FROM OUTSIDE THE UK

Export orders may be subject to local import duties, taxes and Customs clearance fees, which must be paid before receipt of the goods. These charges are NOT included in the price of the goods or the delivery. These charges are normally managed by our carrier & freight forwarder agents. If you use your own shipping agent, please consult them for details. All relevant Customs forms and documentation required to ensure the order arrives with the minimum of delay will be included with your shipment.

## 90 DAY MONEY BACK PEACE OF MIND WARRANTY

It's simple, if you change your mind for any reason, all uninstalled parts still in their original condition and packaging may be returned to us within 90 days from the date of purchase for a full refund. A copy of the original invoice or picking label must accompany the return. Return freight is paid by the customer, unless returned due to our error.

In the event of a part failing in use, all parts are warranted against defects in materials and workmanship for 12 months from the date of purchase. Please remember that all returns must be accompanied by the original invoice, return freight will be reimbursed. For more details see our website or contact your local branch.

**FIND US ONLINE FOR THE LATEST PRODUCTS, NEWS, FEATURES AND SALES.**

STAY IN TOUCH



Facebook  
[facebook.com/mosseurope](https://facebook.com/mosseurope)



Twitter  
[twitter.com/mosseurope](https://twitter.com/mosseurope)



Instagram  
[instagram.com/mosseuropeltd](https://instagram.com/mosseuropeltd)

### BUY ONLINE

Moss Websites

[moss-europe.co.uk](http://moss-europe.co.uk)

[moss-europe.fr](http://moss-europe.fr)



LONDON

### LONDON

Unit 16, Hampton Business Park  
Bolney Way, Feltham  
**TW13 6DB**

London Tel

**+44 (0)20 8867 2020**

Email

[sales@moss-europe.co.uk](mailto:sales@moss-europe.co.uk)

Fax

**+44 (0)20 8867 2030**



BRADFORD

### BRADFORD

Unit 12-13, Acorn Park Ind. Est.  
Otley Road, Shipley  
**BD17 7SW**

Bradford Tel

**+44 (0)1274 539 999**

Email

[bradford@moss-europe.co.uk](mailto:bradford@moss-europe.co.uk)

Fax

**+44 (0)1274 539 990**



BRISTOL

### BRISTOL

Unit 14 Avonside Ind. Park  
Avonside Road, Bristol  
**BS2 0UQ**

Bristol Tel

**+44 (0)117 923 2523**

Email

[bristol@moss-europe.co.uk](mailto:bristol@moss-europe.co.uk)

Fax

**+44 (0)117 300 9164**



MANCHESTER

### MANCHESTER

111-117 Stockport Road  
Stockport, Cheshire  
**SK3 0JE**

Manchester Tel

**+44 (0)161 480 6402**

Email

[manchester@moss-europe.co.uk](mailto:manchester@moss-europe.co.uk)

Fax

**+44 (0)161 429 0349**



PARIS MOTOR DREAM

### PARIS

7 rue Chaponval  
ZAC du Cornouiller  
78870 Bailly, France

Paris Tel

**+33 (0)1 30 80 20 30**

Email

[sales@moss-europe.fr](mailto:sales@moss-europe.fr)

Sav

**+33 (0)1 30 80 21 50**

<b>A</b>		Goodridge Brake Hoses . . . . . 9	Spark Plugs . . . . . 6
Aerials . . . . . 33			Steering Rack Bushes . . . . . 27
Air-Oil Separators . . . . . 28	<b>H</b>	Hawk Brake Pads . . . . . 8	Stubby Aerial . . . . . 33
Anti-Roll Bar Bushes . . . . . 27	Headlamps . . . . . 13	HT Leads . . . . . 6	Sunvisor Blanks . . . . . 38
<b>B</b>			SuperPro Suspension Products . 27
Badges . . . . . 34	<b>I</b>	I.L Motorsport Strut Braces . . . . 23	Suspension Bushes . . . . . 27
Bicycle Rack . . . . . 34	Instrument Cluster Panels . . . . . 16		<b>T</b>
Books . . . . . 12			Tow Hooks . . . . . 11
Boot Brace . . . . . 24	<b>J</b>	Jackson Racing Anti-Roll Bar . . . 22	Track Dog Splitters . . . . . 30
Boot Racks . . . . . 34	Japan Racing Wheels . . . . . 21		Trim Covers . . . . . 16
Boot Storage . . . . . 35	Jass Performance . . . . 14,15,16 &17		<b>U</b>
Brake Pads . . . . . 8	Jass Tow Hooks . . . . . 16		Upper Gear Lever Gaiter . . . . . 19
Bump Stop & Covers . . . . . 26	Jass TSI's . . . . . 14		<b>W</b>
<b>C</b>			Washer Bottle Relocation Kits . . . 7
Car Covers . . . . . 32	<b>K</b>	K&N Oil Filters . . . . . 28	Wilwood Big Brake Kits . . . . . 8
Carpet Sets . . . . . 37	Koyo Radiators . . . . . 10		Wind Deflector Brackets . . . . . 7
Chassic Jacking Bars . . . . . 7			Wing Repeaters . . . . . 13
Chrome Fuel Lids . . . . . 36	<b>L</b>	Low Pro lights . . . . . 15	
Clutch Kits . . . . . 18	Lower Gear Lever Gaiter . . . . . 19		
Clutch Master Cylinders . . . . . 18			
Clutch Slave Cylinders . . . . . 18	<b>M</b>	MazdaSpeed Engine Mounts . . . 26	
Cobalt Anti-Roll Bar . . . . . 22	Mazdaspeed Tow Hooks . . . . . 11		
Cobalt Anti-Roll Bar Links . . . . . 22	MesiterR Suspension Kits . . . . . 26		
Cobalt Extended Clutch Line . . . . 18	Mirrors . . . . . 31		
Cobalt Pedal Sets . . . . . 11	Mishimoto Fans . . . . . 10		
Cobalt Products . . . . . 24,25	Mishimoto Radiators . . . . . 10		
Cobalt Radiators . . . . . 11	Mk4 Upgrades . . . . . 29		
Cobalt Short Shifter . . . . . 19	Moss TSI's . . . . . 31		
Cobalt Skid Plates . . . . . 20			
Cobalt Style Bars . . . . . 12	<b>N</b>	Number Plate Kits . . . . . 33	
Cold Air Intake Kits . . . . . 6	Number Plate Offset Bracket . . . 14		
Coolant Expansion Tanks . . . . . 7	Number Plate Plints . . . . . 33		
Cup Holder . . . . . 38			
<b>D</b>	<b>O</b>	Oil Catch Can . . . . . 7	
DaveFab Products . . . . . 7	Oil Filter Removal Tool . . . . . 16		
DBA Brake Discs . . . . . 9			
Delrin Door Bushes . . . . . 25	<b>P</b>	Pedal Rubbers . . . . . 11	
Delrin Window Bushes . . . . . 38	Project M Spoilers . . . . . 31		
Door Pulls . . . . . 15			
Door Trim Panels . . . . . 37	<b>R</b>	R Speed Lips . . . . . 30	
Drift Button . . . . . 15	Racing Beat Anti-Roll Bar Links . 23		
<b>E</b>	Radiator Cowls . . . . . 7		
EBC Brake Pads . . . . . 8 & 9	Radiator Slam Panels . . . . . 10		
Engine Hooks . . . . . 14	Remote Filter Kit . . . . . 28		
Engine Strut Brace . . . . . 25	Retro Electric Window Switch . . 16		
Enkei Wheels . . . . . 30			
Exhaust Manifolds . . . . . 5	<b>S</b>	Seatbelt Tower Brace . . . . . 24	
Exhaust Silencers . . . . . 4	Servo Brake Stopper . . . . . 14		
<b>F</b>	Shifter Rebuilt Kits Standard . . . 19		
Fidanza Cam Gears . . . . . 19	Shifter Rebuilt Kits Upgraded . . 19		
Flyin Miata Anti-Roll Bars . . . . . 22	Side Reflectors . . . . . 13		
Frame Rails . . . . . 15			
Front Lower Braces . . . . . 25			
Fuse Box Lids . . . . . 14			
<b>G</b>			
Gauge Holders . . . . . 36			
Gear Knobs . . . . . 39 &40			
Gear Stick Extender . . . . . 15			

## Sections

Performance 04

Exterior 30

Interior 36

## BLACK & WHITE Restoration Section

Ordering  
Information 42

Restoration  
Parts 43



**Moss Europe Ltd are proud  
to support the FBHVC**

The Federation of British Historic Vehicle Clubs exists to uphold the freedom to use old vehicles on the road.

Where the price is replaced with NCA this part is Not Currently Available. Please visit our website ([moss-europe.co.uk](http://moss-europe.co.uk)) or call our sales staff for the latest availability information or to enquire if we can offer an alternative part.

MX5cat ©Copyright Moss Europe Ltd. August 2021. Printed in the U.K. All rights reserved. No part of this publication may be reproduced, stored in a retrieval system, or transmitted in any form by any means, electronic, photocopying, recording or otherwise without prior written consent of Moss Europe Ltd. Please note: Product colours may vary slightly to samples featured in this catalogue, due to the limitations of colour printing.



901-304



**COBALT EXHAUSTS**

Treat your MX-5 to one of the finest exhausts available exclusively from Moss. These beautifully finished mirror polished exhausts are packed with features usually only found on more expensive systems.

- 1.2mm thick 304 stainless steel used for silencer shell, tips, and piping
- Silencer packing is a combination of stainless steel wool and fibreglass for a perfect sportscar sound that is never intrusive
- CNC cut stainless steel flanges
- 409 stainless steel used for inner core and perforated tubing
- 60mm pipe diameter
- Beautifully shaped oval silencer
- All welds on silencer are ground smooth and polished
- Entire silencer completely polished to a mirror shine
- Polished tail pipe
- 5 year warranty

**Mk1 (1989-97)**

Cat-back, stainless steel, single exit . . . . . 901-304 . . . . .**£210.50**  
(Fits cars with 375 or 440mm cat only)

Cat-back, stainless steel, twin exit . . . . . 900-482 . . . . .**£255.50**  
(Will only fit with 375 or 440mm cat)

Blanking plug . . . . . WPE1104X . . . . .**£4.50**  
(May be required on 901-304 or 900-482)

**Mk2 (1998-05)**

Single exit stainless steel silencer, 1998-05 . . . . . 900-566 . . . . .**£190.00**

Dual exit stainless steel silencer, 1998-05 . . . . . 909-680 . . . . .**£285.00**

**Mk3 (2005-15)**

Dual exit stainless steel silencer, 2005-15 . . . . . 909-699 . . . . .**£210.20**  
(Will not fit with appearance package)

**Mk4 (2016 on)**

Twin exit stainless steel silencer . . . . . 910-620 . . . . .**£245.00**

910-620

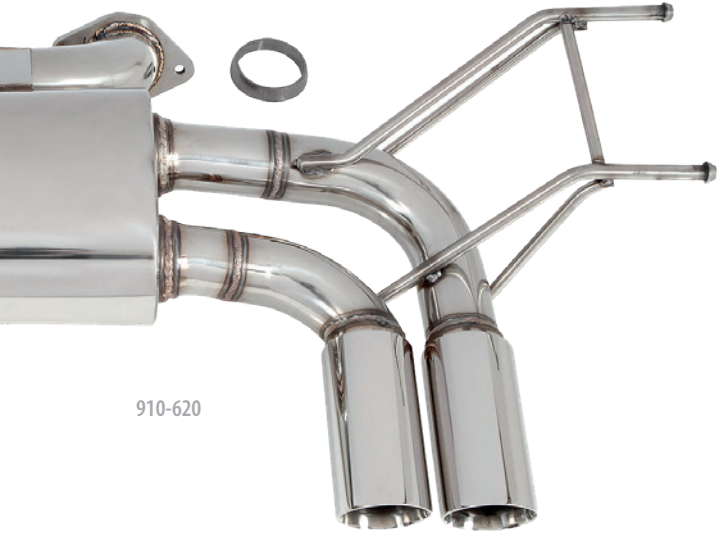

900-482

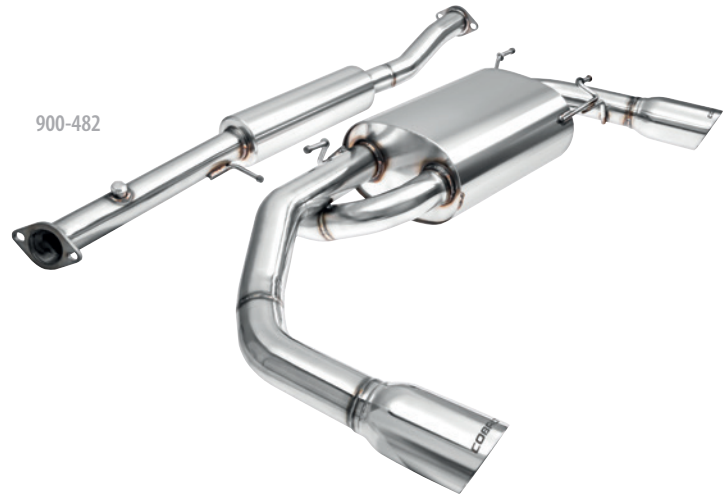

900-566

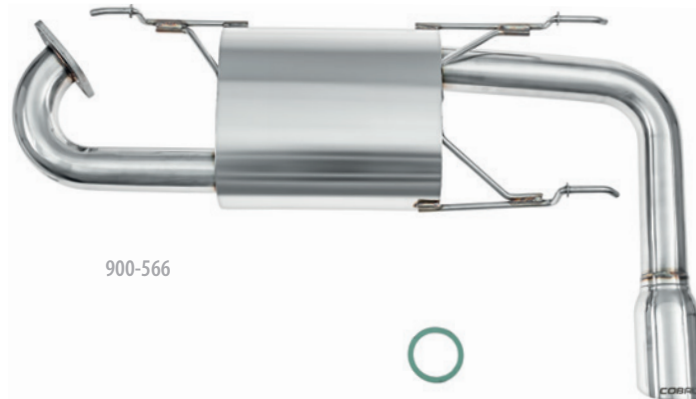

909-680





**COBALT MANIFOLDS**

The Cobalt manifold pulls hard through a wide power-band without that head-throbbing resonance often found in low-quality manifolds. Features include heavy gauge steel, mandrel bent tubes, CNC-machined flanges and ceramic coating. The result is a TIG-welded manifold that provides maximum performance, total precision and lifelong durability.

- Mk1 (1989-97)**  
4-2-1 Sports manifold, 1.6..... 903-110..... **£520.00**  
(Fits manual transmission only)
- 4-2-1 Sports manifold, 1.8..... 903-120..... **£520.00**  
(Fits manual transmission only)

- Mk2 (1998-05)**  
4-2-1 Sports manifold, 1.8..... 910-645..... **£348.00**

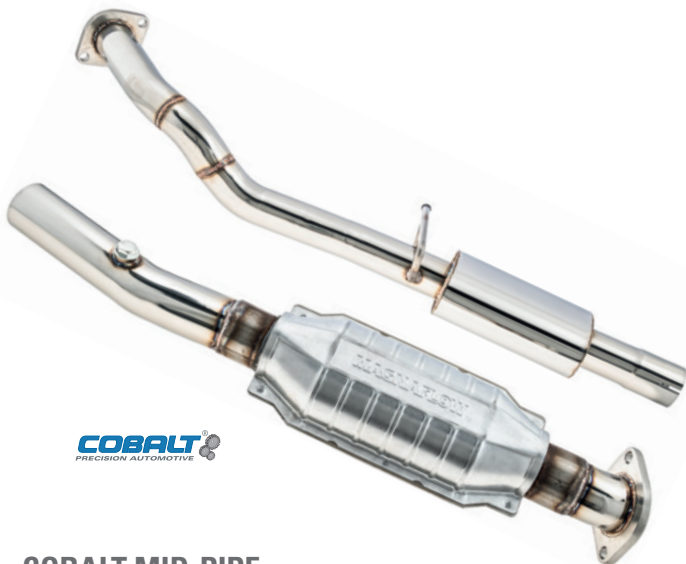

**COBALT MID-PIPE**

Full stainless steel 2.5" pipes and welded-in Magnaflow catalytic converter, this bolts to factory or Cobalt manifolds and silencers. Factory location O2 connection. Includes magnaflow catalyst converter.

Please note: This is a direct fit for 1998-99 MX-5 models. To fit 2000-05 MX-5's a performance manifold will need to be installed.

- Cobalt performance mid-pipe, 1989-05..... 909-960..... **£339.00**



**MANIFOLD HEAT SHIELD**

The exhaust manifold is the main source of heat under your MX-5's bonnet. By covering and isolating it with a Track Dog heat shield you will prolong the life of rubber engine parts. In addition, air entering your engine will be cooler allowing for maximum power to be generated from your MX-5. Can be fitted to all factory and aftermarket manifolds.

- Manifold blanket/heat shield..... 971-450..... **£134.20**



**RACING BEAT MANIFOLD**

Manufactured entirely from 304-stainless steel to provide both outstanding durability and appearance, the Racing Beat 4-to-1 configured header is sure to offer the MX-5 owner many years of performance. Their exclusive, cast stainless-steel engine-to-header flange features specially designed exhaust ports that transition smoothly to the primary tubing. Large diameter 1.7" O.D. tubing has been used for the primary tubing, collecting into a specially configured collector assembly. Exhaust gas exits the header through an OEM stainless-steel rear flange, mating to the factory connecting pipe section.

- Stainless steel manifold, 2005-15..... 904-955..... **£535.00**



**ROADSTERSPORT SUPERQ EXHAUST**

For those looking to change the look and exhaust tone of their Mk4 MX-5, but not wanting it to be over bearingly loud or obnoxious, RoadsterSport have created the SuperQ backbox. Designed to stay quiet, whilst changing the look of the rear end of the Mk4 MX-5. Comes with a lifetime warranty.

- Stainless steel silencer, 2016 on..... 910-710..... **£610.10**



**JACKSON RACING AIR INTAKE KIT**

The Jackson Racing cold air intake allows your car to breath clean, cool air for maximum horsepower, up to 14HP in most cases. If you are old enough to remember the old muscle cars with cowl-air induction and Ram-Air Induction, you know that cold air does help performance. Instead of adding one of those unsightly hoods that you can barely see over, the JR cold air induction system tucks neatly under the bonnet. A strategically placed scoop brings cold air into the throttle body with increased velocity. The combination of cool air and pressurised air (at speed) will increase your horsepower. Each system includes a high-velocity air filter for increased airflow and filtration.

- Cold air intake, 1989-97, 1.6 . . . . . MXV1176X. . .£343.90
- Replacement filter, 1989-97. . . . . 901-987. . . . .£36.80
- Up rated panel filter, 1989-05 . . . . . 901-975. . . . .£31.00  
(Fits factory air box)



971-510



971-108

**JACKSON RACING AND COBALT HT LEAD SETS**

Cobalt ignition wire sets are made precisely for your vehicle, and carry a Lifetime Warranty against defective materials or workmanship! The Cobalt wires feature:

- Compact silicone plug boots provide extra clearance
- EPDM layer provides more electrical insulation than silicone-over-silicone
- Conductive polymer coating protects the conductor and provides terminal contact
- Stainless steel conductor for maximum conductivity
- Aramid fibers provide superior tensile strength
- Spiral magnetic core suppresses RFI/EMI interference
- Fiberglass braid provides superior tensile strength
- 8mm silicone jacket resists high temperatures, fuels and oils
- Locking terminals stay connected under high vibration

- Cobalt HT lead set (set of four), 1989-00 . . . . . 971-108. . . . .£29.60
- Cobalt HT lead set (set of two), 2001-05 . . . . . 971-109. . . . .£14.80
- JR HT lead set (set of four), 1989-00 . . . . . 971-510. . . . .£26.60



909-605

**COBALT COLD AIR INTAKE**

Clean up the front of your engine; add a nice growl sound on acceleration, and a little more power too with this Air Intake System by Cobalt. Designed with a shield to keep intake air cool and protected from hot ambient engine temperatures, also features a reusable K&N brand filter. The arm is rotomolded and textured black plastic, and the heat shield is black painted steel. Includes all installation hardware and instructions.

- Cold air intake, 1998-05 . . . . . 909-605. . . . .£178.00
- Cold air intake, 2005-15 . . . . . 904-377. . . . .£54.70



BKR7EIX-11 BKR5E-11 971-116 BKR6E-11 BKR6EVX-11

**SPARK PLUGS FROM NGK**



Not all spark plugs are created equal! NGK plugs are constructed for longer life and optimum performance. Pick up an extra set for your toolbox. Plugs should arrive pre-gapped although it never hurts to double check! (Sold individually).

- NGK spark plug, 1989-93, 1.6 . . . . . BKR6E-11. . . . .£3.30
- NGK spark plug, 1989-93, 1.6 Platinum . . . . . BKR6EVX-11 . .£11.90
- NGK spark plug, 1989-93, 1.6 Supercharged . . . . . BKR7EIX-11. .£11.50
- NGK spark plug, 1994-97, 1.8 . . . . . BKR5E-11. . . . .£3.40
- NGK spark plug, 1994-05, 1.8 Iridium. . . . . 971-116. . . . .£11.60

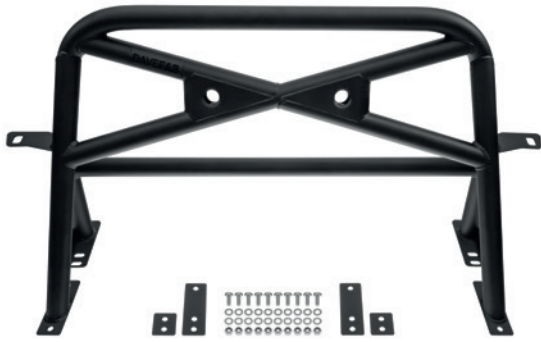

**ROLL BAR**

The roll bar is hand built in the UK from specifically chosen fully certified PTG700 tube which has a tensile strength between 700n/mm2 - 900n/mm2. The minimum yield strength (when metal starts to deform) of PTG700 (620N/mm2) is almost double that of its cold drawn seamless steel counterparts.

Roll Bar, 1989-05 . . . . . MXV155130 . **£392.00**



DAVEFAB

**CHASSIS JACKING BARS**

Add stiffness and functionality with the DaveFab rear chassis bar. Replacing the original 2 factory tow hooks and fabricated from CDS roll cage steel. Designed not only to be functional, but to look good, too.

Chassis jacking bars, 1989-97 . . . . . MXV155110 . **£140.00**

Chassis jacking bars, 1998-05 . . . . . MXV155111 . **£140.00**



DAVEFAB

**WASHER BOTTLE RELOCATION KITS**

Essential if you've fitted your 5 a turbo and don't want to melt the original plastic washer bottle, or if you just want to tidy the area under the bonnet for that 'clean' look. Includes all parts required to fit and utilises the original washer pump.

Washer bottle relocation kits, RHD, 1989-05 . . . MXV155210 . **£120.00**

Washer bottle relocation kits, LHD, 1989-05 . . . MXV155211 . **£120.00**

Washer bottle, 2005-15 . . . . . MXV155120 . **£155.00**

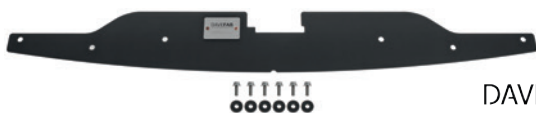

DAVEFAB

**RADIATOR COWLS**

Tidy up under the bonnet and increase cooling efficiency at the same time with these DaveFab radiator cowls. By ensuring any air going through the mouth of your MX-5 goes through the radiator instead of up and over it cooling efficiency is drastically improved both on track and in general driving conditions.

Radiator cowl, 1989-97 . . . . . MXV155112 . **£45.00**

Radiator cowl, 1998-05 . . . . . MXV155113 . **£45.70**



MXV155115

DAVEFAB

**COOLANT EXPANSION TANKS**

Factory tanks after many years of use and abuse tend to turn brittle and can break when you least expect it, so why not replace it with one from DaveFab. TIG welded, laser cut and beautifully made from Aluminium with a glass sight gauge to help you keep an eye on coolant levels, this is the perfect addition to your engine bay, and unlike the factory item, will never go brittle.

Coolant expansion tanks, 1989-97 . . . . . MXV155115 . **£160.00**

Coolant expansion tanks, 1998-05 . . . . . MXV155116 . **£144.90**

Coolant expansion tanks, 2005-15 . . . . . MXV155118 . **£190.00**



DAVEFAB

**OIL CATCH CAN**

Specifically designed for the MX-5 from the ground up comes DaveFab's fantastic oil catch can, by going in line with the PCV system of your MX-5 this removes and oil fumes and vapours from entering the combustion process, helping to keep fuel octane ratings up and at the same time, keeping your inlet tract clean. Internally baffled and totally leak free, we believe this is one of, if not the best oil catch can on the market for your MX-5 today.

Oil catch can, 1989-05 . . . . . MXV155117 . **£140.00**

Oil catch can, 2005-15 . . . . . MXV155120 . **£155.00**



**MK3 ENGINE ACCESSORIES**

MXV155124

Upgrade your engine bay appearance with these aluminium cover panels coated on DaveFab's signature texture black powdercoat. Simple and effective upgrades.

Engine cover, 2005-15 . . . . . MXV155121 . **£110.00**

Battery cover, 2005-15 . . . . . MXV155122 . **£22.00**

Fuse box cover, 2005-15 . . . . . MXV155123 . **£18.00**

ECU cover, 2005-15 . . . . . MXV155124 . **£45.00**



901-550

**HAWK BRAKE PADS**

Hawk brake pads are manufactured using the highest quality materials available for street-performance driving. For the serious performance driver, this is the best brake pad we offer.

Hawk Performance's HP Plus brake pad compound is ideal for Autocross and Track Day drivers looking for a high performance race compound that can take the heat of the track and get you home safely without having to change the pads. HP Plus utilises a unique Ferro-Carbon, high-tech friction material that was developed and manufactured for sport driving in autocross, Solo II and track day applications. The Ferro-Carbon formulation offers lower wear rates and higher torque values than other competitive materials. Extremely high coefficient of friction makes HP Plus the perfect upgrade over stock for high performance streetcars used in autocross competition or that experience repetitive, heavy braking.

**Mk1 1.6 (1989-97)**

Brake pads, front, set . . . . . 901-550 . . . . . **£132.00**

Brake pads, rear, set . . . . . 901-555 . . . . . **£133.20**

**Mk1 1.8 & Mk2-2.5 non-sport brake models (1989-05)**

Brake pads, front, set . . . . . 901-560 . . . . . **£137.30**  
(To fit 255mm brake discs.)

Brake pads, rear, set . . . . . 901-565 . . . . . **£143.20**  
(To fit 251mm brake discs.)



**WILWOOD BIG BRAKE KITS**

Trust the Wilwood name to get your high performance MX-5 to stop on a penny. Billet 4 piston calipers, huge 11" rotors and Wilwood's BP-10 pad material will help your MX-5 come to a stop like never before. Designed to be a direct fit to any Mk1, 2 or 2.5, with or without ABS. A Wilwood hose set will also need to be purchased (sold separately).

Big brake kit, front, vented, 1989-05 . . . . . 906-160 . . . . . **£760.60**

Big brake kit, front, drilled/slotted, 1989-05 . . . . . 906-162 . . . . . **£894.10**

Brake hose set, Wilwood . . . . . 906-170 . . . . . **£73.60**



901-565



MXV1270G



MXV1273G



MX51272G



**EBC BRAKES GREENSTUFF**

EBC's latest formulation for use on fast street or light duty race use. Good bite from cold and effective to 550°C. Reduced accumulation of brake dust and the improved thermal conductivity prevents disc warping. Asbestos free.

**Mk1 1.6 (1989-97)**

Brake pads, front, set . . . . . MXV1270G . . . **£61.80**

Brake pads, rear, set . . . . . MXV1271G . . . **£53.00**

**Mk1 1.8 & Mk2-2.5 non-sport brake models (1989-05)**

Brake pads, front, set . . . . . MXV1272G . . . **£70.30**  
(To fit 255mm brake discs.)

Brake pads, rear, set . . . . . MXV1270G . . . **£61.80**  
(To fit 251mm brake discs.)

**Mk2.5 sport brake models (2001-05)**

Brake pads, front, set . . . . . MX51272G . . . **£69.20**  
(To fit 270mm discs.)

Brake pads, rear, set . . . . . MX51273G . . . **£51.90**  
(To fit 276mm discs.)

**Mk3 (2005-15)**

Brake pads, front, set . . . . . MXV1274G . . . **£75.80**

Brake pads, rear, set . . . . . MXV1275G . . . **£70.30**



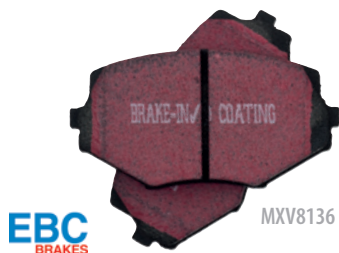

### EBC BRAKES ULTIMAX/BLACKSTUFF

Brake pads are a simple investment that can save you from costly repairs. EBC pads offer performance, without the need to build tremendous heat to make them work.

**Mk1 1.6 (1989-97)**

- Brake pads, front, set . . . . . MXV8135 . . . £23.80
- Brake pads, rear, set . . . . . MXV8138 . . . £17.40

**Mk1 1.8 & Mk2-2.5 non-sport brake models (1989-05)**

- Brake pads, front, set . . . . . MXV8136 . . . £25.90  
(To fit 255mm brake discs.)
- Brake pads, rear, set . . . . . MXV8137 . . . £23.80  
(To fit 251mm brake discs.)



### EBC BRAKES REDSTUFF

Redstuff pads are better suited for fast road driving and cars that are above 200bhp. RedStuff is a truly impressive fast road pad for repeated heavy braking. It emits far less dust than semi-metallic pads, and features EBC Brake-In™ surface coating which conditions the rotor surface and accelerates pad bed-in.

**Mk1 1.6 (1989-97)**

- Brake pads, front, set . . . . . MXV1270R . . £73.60
- Brake pads, rear, set . . . . . MXV1271R . . £69.30

**Mk1 1.8 & Mk2-2.5 non-sport brake models (1989-05)**

- Brake pads, front, set . . . . . MXV1272R . . £87.60  
(To fit 255mm brake discs.)
- Brake pads, rear, set . . . . . MXV1273R . . £70.30  
(To fit 251mm brake discs.)

**Mk2.5 sport brake models (2001-05)**

- Brake pads, front, set . . . . . MX51272R . . £87.60  
(To fit 270mm discs.)
- Brake pads, rear, set . . . . . MX51273R . . £68.10  
(To fit 276mm discs.)

**Mk3 (2005-15)**

- Brake pads, front, set . . . . . MXV1274R . . £103.90
- Brake pads, rear, set . . . . . MXV1275R . . £87.60



### DBA BRAKE DISCS

Get the stopping power you need. Cross-drilled holes lower brake temperatures and reduce rotational mass and out-gassing, while slots allow excess water, dirt and dust to dissipate. Simply the best disc we offer. Sold as a pair.

**Mk1 1.6 (1989-97)**

- Front brake disc . . . . . 901-050 . . . £152.10
- Rear brake disc . . . . . 901-055 . . . £133.40

**Mk1 1.8 & Mk2-2.5 non-sport brake models (1989-05)**

- Front Brake disc . . . . . 901-060 . . . £154.40  
(To fit 255mm brake discs.)
- Rear brake disc . . . . . 901-065 . . . £154.40  
(To fit 251mm brake discs.)

**Mk2.5 sport brake models (2001-05)**

- Front brake disc . . . . . 901-070 . . . £195.70  
(To fit 270mm discs.)
- Rear brake disc . . . . . 901-075 . . . £151.90  
(To fit 276mm discs.)

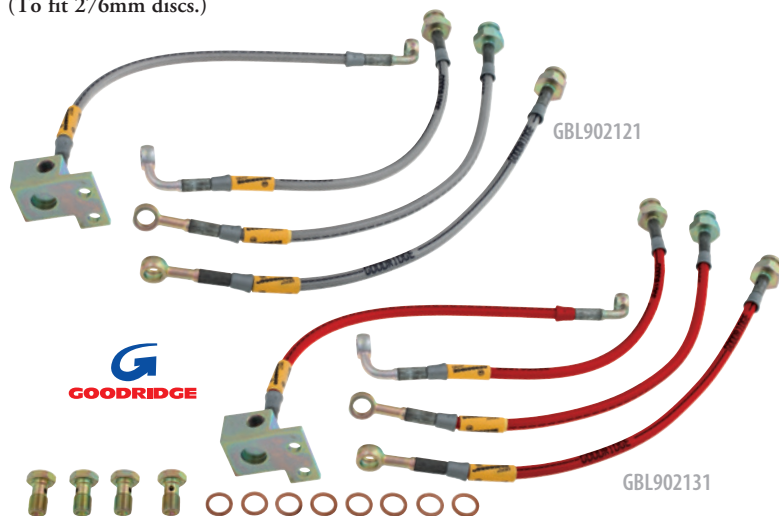

### GOODRIDGE BRAKE HOSES

Our high performance stainless braided brake lines eliminate the mushy pedal feel you get when your OEM rubber lines expand. Utilizing Teflon tubing with a stainless steel outer tube, this 4-line set is DOT-approved, and works perfectly on the track or on the street. Includes all necessary mounting hardware. Sets available in silver or red.

**Mk1-2.5 (1989-05)**

- Brake hoses, silver, set . . . . . GBL902121 . . £91.20
- Brake hoses, red, set . . . . . GBL902131 . . £91.20

**Mk2.5 sport brakes (2001-05)**

- Brake hoses, clear, set . . . . . GBL902122 . . £123.00

**Mk3 (2005-15)**

- Brake hoses, silver, set . . . . . GBL902123 . . £100.70
- Brake hoses, red, set . . . . . GBL902133 . . £100.70



**MISHIMOTO RADIATORS**

Mishimoto is a go to brand for build quality and genuine results and their radiators for the MX-5 are no different. Unlike the OE radiators, Mishimoto’s radiators full aluminium construction means there’s no plastic to go brittle and break, ensuring you can drive your car hard lap after lap without worries. Designed to be a direct replacement requiring no modifications. Fits manual transmission only.

- No modifications to fit
- All radiators come with new cap
- Limited lifetime warranty

Radiator, Mishimoto, 2 row, 1989-97 . . . . . 909-560 . . . . .£275.20  
 Radiator, Mishimoto, 3 row, 1990-97 . . . . . 909-561 . . . . .£344.40  
 Radiator, Mishimoto, 2 row, 1998-05 . . . . . 909-562 . . . . .£266.90

**KOYO RADIATORS**

Redefining the word ‘quality’ is Koyos mantra, crafted around Koyorad’s 36mm Hyper Core-V series all aluminium core, which in turn was developed for cars that see extreme levels of heat or have limited space. With their special design which increases surface area while still allowing for excellent air circulation. Designed to be completely ‘plug & play’ complete with drain plug and cap. Fits manual transmission only.

Radiator, Koyo, 1989-97 . . . . . 910-370 . . . . .£361.00  
 Radiator, Koyo, 1998-05 . . . . . 910-371 . . . . .£352.90  
 Radiator, Koyo, 2005-15 . . . . . 910-372 . . . . .£494.00  
 Radiator, Koyo, 2015-On . . . . . 910-373 . . . . .£479.00  
 Radiator Cap, Koyo, 1989-On . . . . . 910-374 . . . . .£31.80



**MISHIMOTO TWIN FANS**

The Mishimoto Mazda MX-5 fan shroud kit will considerably improve engine cooling functions and the overall performance of your vehicle. All Mishimoto fan shrouds are significantly lighter than standard fan shrouds, and fit the Mishimoto aftermarket radiator. A Mishimoto fan shroud will effectively drive out heat from the engine bay and deliver a significant amount of cooler air directly to your new Mishimoto radiator. At the same time the fan shroud serves another very important purpose: securing the fan blades. The fan shroud will keep the fan blades in place, which otherwise could potentially damage other essential components in your engine. Includes fans and motors.

Twin fan kit, Mishimoto, 1989-97 . . . . . 909-565 . . . . .£201.40  
 Twin fan kit, Mishimoto, 1998-05 . . . . . 909-566 . . . . .£201.40

**TOURIST TROPHY RADIATOR SLAM PANEL**

Precision cut from polished stainless steel, this radiator cowl cover really dresses up your engine bay. It also closes off an area where some air can escape over the top of your radiator, instead of going straight through. Adds a bit of cooling efficiency and a great look! Supplied with fittings.

Slam panel, polished, 1989-97 . . . . . 902-497 . . . . .£32.90  
 Slam panel, polished, 1998-05 . . . . . 902-498 . . . . .£30.10

**TRACK DOG RACING RADIATOR SLAM PANEL**

Increase your cooling efficiency and dress up your MX-5. The TDR radiator cowl covers the area between the bumper and the radiator forcing incoming air through your radiator instead of letting it escape over the top. All aluminium construction with a black wrinkle powder-coated finish and accented with an engraved Track Dog Racing badge.

Slam panel, black, 1989-97 . . . . . 904-710 . . . . .£70.20



**COBALT RADIATORS**

Get every ounce of cooling efficient from our brand new aluminium radiators by Cobalt. Unlike the plastic end tanked stock radiators which would leak, crack or clog over time, these aluminium radiators have a long life and will perfectly replace the factory unit to keep your cooling system in top notch shape. Please Note: Fits for manual transmission only.

- Radiator, Cobalt, 1989-97 . . . . . 908-140 . . . . . **£169.00**
- Radiator, Cobalt, 1998-05 . . . . . 908-141 . . . . . **£179.00**



**MAZDASPEED**

**MAZDASPEED TOW HOOKS**

Specifically designed to bolt right up to existing holes, these tow hooks are SCCA legal for racing applications. These are the hooks the track officials use to clip the tow line to your MX-5, to get it off the track if it's disabled.

- Tow hooks, Mazdaspeed, red, 1989-97 . . . . . 903-985 . . . . . **£76.00**



**TOW HOOKS**

If you're building a Spec MX-5 for racing, these are required. Or, throw a pair on the street MX-5 you occasionally take to the track. Either way, these are what the officials use to hook your car to the tow line to haul your MX-5 off the track if it's disabled. '99 MX-5's will need one hole drilled, instructions included. Sold as a pair.

- Tow hooks, red, 1998-05 . . . . . 909-280 . . . . . **£34.00**
- Tow hooks, silver, 1998-05 . . . . . 909-281 . . . . . **£44.50**

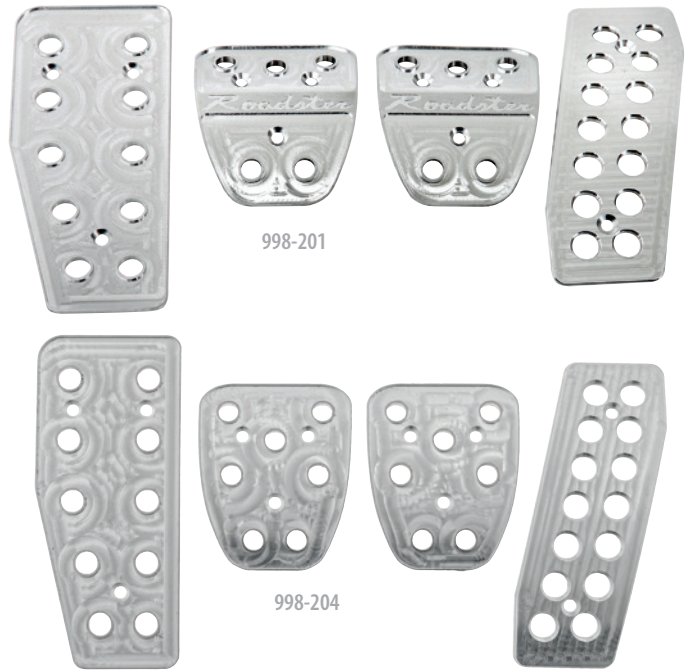

998-201

998-204



**COBALT**  
PRECISION AUTOMOTIVE

**COBALT PEDAL SETS**

Your feet are an integral part of the MX-5 driving experience. From the factory, your MX-5's control pedals are meant to work with a wide variety of driving tastes. Cobalt's billet pedal system is the ultimate for those of you who want to feel one with the road. Made specifically for the MX-5 and machined from aircraft quality aluminium, you will enjoy improved feel of the controls and outstanding grip. More experienced drivers will appreciate the ability to "Heel & Toe". Set includes accelerator, brake, clutch and footrest pedals. Comes complete with instructions and easily installed using simple hand tools, may require drilling. Sets of four.

- Pedal set, Roadster logo, billet finish, 1989-97 . . . . . 998-201 . . . . . **£63.90**
- Pedal set, Roadster logo, billet finish, 1998-05 . . . . . 998-203 . . . . . **£63.90**
- Pedal set, no logo, billet finish, 1989-97 . . . . . 998-204 . . . . . **£63.90**
- Pedal set, no logo, billet finish, 1998-05 . . . . . 998-205 . . . . . **£63.90**



900-351

900-341

**PEDAL RUBBERS**

Keep your pedals from feeling greased-up when it rains. Our new pedal material helps prevent you from slipping even when your feet are wet. Roadster Logo (Manual Transmission only).

- Accelerator pad, rubber, 1989-05 . . . . . 900-351 . . . . . **£7.40**
- Clutch/brake pad, rubber, 1989-05 . . . . . 900-341 . . . . . **£4.30**



**STYLE BARS**

Another Moss exclusive! This new style bar by Cobalt is manufactured so that no cutting of your interior body panels is required! Additionally, seat travel and recline are not impeded in any way. Available in your choice of chrome or black painted. Easily installs in about 30 minutes with simple hand tools. Instructions included. Do not work with 99-05 factory wind blocker. On 94-97 MX-5's the factory seat tower brace must be removed. Please note: These style bars are decorative items only and not intended for roll over protection.

- Style bar, Cobalt, chrome, 1989-05 . . . . . 903-305 . . . . . **£116.40**
  - Stly ebar, Cobalt, chrome, 1989-05 . . . . . 903-310 . . . . . **£101.50**
  - Windblocker, Cobalt, 1989-05 . . . . . 904-151 . . . . . **£189.10**
- (Fits Cobalt style bar 903-305/903-310)

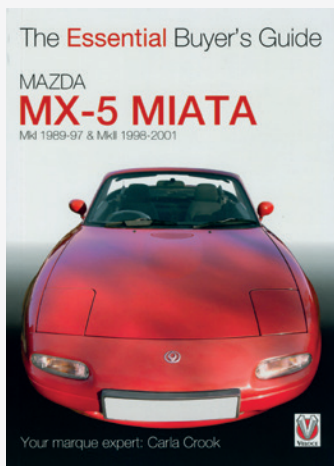

**MX-5 MK1 BY BRIAN LONG**

Researched and written in Japan, with the full cooperation of the factory, here, in definitive detail is the complete story of the 1st generation MX-5, the car that reinvented the affordable, lightweight roadster.

1989-97 . . . . . MGL0365 . . . . . **£30.00**

**MX-5 MK2 BY BRIAN LONG**

Researched and written in Japan, with the full cooperation of the factory, this is the definitive story of the second generation of the world's best-selling sports car, the Mazda MX-5.

1998-05 . . . . . MGL0366 . . . . . **£30.00**

**ESSENTIAL BUYERS GUIDE, MX-5, MK1-2**

Having this book in your pocket is just like having a marque expert by your side. Benefit from the authors years of real ownership experience, learn how to spot a bad car quickly, and how to assess a promising one like a true professional. Get the right car at the right price!

1989-01 . . . . . MGL0412 . . . . . **£10.00**

**ROD'S WORKSHOP MANUAL**

The super manual, written by Rod Grainger, who has personally dismantled and reassembled a MX-5, purely for this book. Taking step-by-step pictures of all the procedures. Coverage includes maintenance, repairs, modification and improvements. All done to a 1.8 Mk1, however, most information will also apply to Mk1 1.6's, too.

1989-97 . . . . . 211-575 . . . . . **£40.00**

**PERFORMANCE PORTFOLIO**

Experts from four continents comment on the second generation of the Miata/MX-5. The models covered include the 1.6L, 1.8L and Sport, the Turbocharged and 10th Anniversary edition together with the LS, SP and SVT. Included are road and comparison tests, new model introductions and updates, long term reports, plus performance data and specifications.

1998-05 . . . . . 904-715 . . . . . **£15.50**



**REFLECTORS**

Replace your factory reflectors with these stylish clear markers. Sold as a pair, not DOT approved. Two kits required per car.

Side marker/reflector kit clear, 1989-05. . . . . 162-890. . . . . **£49.10**



MXV1337

MXV1339

MXV1338

**WING REPEATERS**

Amazing quality smoked or clear side repeaters with chrome ring, supplied as a pair with two amber bulbs.

Wing repeaters, clear, pair, 1989-05 . . . . . MXV1337 . . . . . **£27.20**

Wing repeaters, smoked, pair, 1989-05 . . . . . MXV1338 . . . . . **£40.50**

Wing repeater rings, chrome, single, 1989-05 . . . . . MXV1339 . . . . . **£10.70**



MXV1227



GLB472



GAC4022X



GLB472BLU



GLB472X

**LIGHT UNITS**

Are you fed up of your candle bright headlamps then why not upgrade to one of our Wipac conversions, replaceable H4 bulb. Sold in pairs and supplied with bulbs. Fancy an upgrade why not try some of our brighter bulbs.

Headlamp kit, halogen, 1989-97 . . . . . MXV1227 . . . . . **£48.40**  
(Pair of housings & bulbs)

Headlamp kit, crystal clear, 1989-97 . . . . . GAC4022X . . . . . **£62.00**

Headlight bulb, standard, H4, 1989-97, single . . . . . GLB472. . . . . **£5.40**

Headlight bulb, blue, H4, 1989-97, pair . . . . . GLB472BLU . . . . . **£10.80**

Headlight bulb, super white, H4, 1989-97, pair . . . . . GLB472X . . . . . **£10.80**



**LED HEADLAMP CONVERSION**

Producing light levels of 3000 lumens per bulb, this LED conversion kit is 3 times brighter than a standard Halogen H4 bulb, meaning vastly improved visibility and safety when driving your classic car at night. Emitting a bright white 6000K colour and a 10,000+ hour lifespan, you'll never worry about visibility in low light conditions again. Features; A pair of premium quality 25W LUMILED LUXEON Z ES LED H4 light units and low load plug and play dual polarity drivers. Note: Suitable for H4 light units only and not suitable for sealed beam lamps.

H4 LED conversion. . . . . 171-250. . . . . **£94.00**



Vlad graduated with a degree in mechanical engineering in Germany and worked as a concept engineer for BMW for years in Munich, with having a close overview of all aspects of car engineering his passion for cars and racing has got bigger and bigger. Vlad was participating with an MX-5 in racing events in Germany and AE86 in Bulgaria which then led to Jass performance being born.

Jass Performance was started in 2010, utilising the resources of Jass Engineering, Vlad's founding company providing engineering solutions (construction & production) to the German automotive industry. The idea behind Jass Performance was to provide fellow enthusiasts the same opportunity to help develop their own projects, as people are having unique and good ideas.

Vlad took this on board and made these products. All parts that have been developed through the years were offered to everyone out there. True automotive functionality behind the products, Vlad gets a lot of his ideas from racing his roadster and thinking what could I design next to improve things or what I could I use to make that look better.

Vlad's enthusiasm for the little roadster has led to some of the best looking parts available on the market today, the more we all ask for the more he will design and continue to offer some amazing products.



Dip stick handle, 1989-05 . . . . . MXV14121 . . . £20.00



Offset number plate bracket black, 1989-05 . . . MXV14031 . . . £20.00  
 Offset number plate bracket polished, 1989-05 . . MXV14032 . . . £16.00

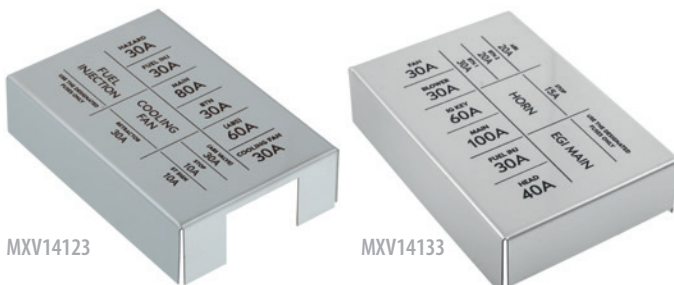

Engraved fuse box lid, 1989-97 . . . . . MXV14123 . . . £20.00  
 Engraved fuse box lid, 1998-05 . . . . . MXV14133 . . . £20.00



MXV14041



MXV14042



MXV14043

TSL's, classic, 1989-97 . . . . . MXV14041 . . £149.00  
 TSL's, stealth, 1989-97 . . . . . MXV14042 . . £149.00  
 TSL's, stealth, LED, 1989-97 . . . . . MXV14043 . . £162.00



MXV14082

MXV14081

Engine hook, stainless steel rear, 1989-05 . . . . . MXV14082 . . £17.00  
 Engine hook, stainless steel front, 1989-05 . . . . . MXV14081 . . £15.00



Servo/brake stopper/trurret mount, 1989-05 . . . . . MXV14010 . . . £42.00



**SUN VISOR BLANKS WITH LIGHTS LED**

These Sun visor interior lights are a direct replacement for the stock sun visors. Using strong LED's they will light the interior and entrance area. All fitting hardware supplied.

Sun visor blanks, with LED lights, 1989-05 . . . . MXV14124 . . . £58.00



MXV14227

MXV14226

MXV14225



MXV14228



MXV14073

MXV14072

MXV14071

Gear stick extender, polished 1", 1989-05 . . . . . MXV14073 . . . £23.00

Gear stick extender, red 2", 1989-05 . . . . . MXV14072 . . . £23.00

Gear stick extender, black 1", 1989-05 . . . . . MXV14071 . . . £23.00

(All extenders fit manual cars only).

Door pulls, plain, 1989-97 . . . . . MXV14227 . . . . . NCA

Door pulls, MX-5 logo, 1989-97 . . . . . MXV14226 . . . £25.00

Door pulls, Roadster logo, 1989-97 . . . . . MXV14225 . . . £25.00

Door pulls, vintage polished, 1989-97 . . . . . MXV14228 . . . £53.00

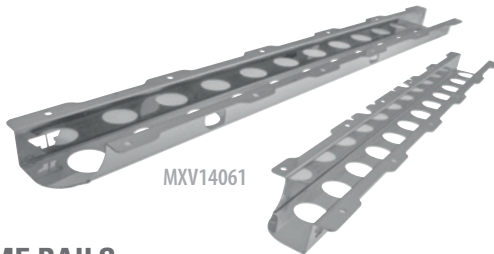

MXV14061

**FRAME RAILS**

They stiffen the convertible body structure of the MX-5 offering rustproof under floor protection especially on lowered cars. They also provide strong points for jacking the car.

Frame rails, stainless steel, 2.9kg each, 1989-05 . MXV14061 . . £128.00

Frame rails, stainless steel, heavy duty, 1989-05 . MXV14062 . . £128.00



**DRIFT BUTTON**

A direct replacement for the stock version but with a twist, you can install for looks to match your handbrake sleeve and gearknob or when fitting remove the spring inside and install, you will loose the locking side of the handbrake but if your using your car for drifting events this is perfect.

Drift button, 1989-05 . . . . . MXV14340 . . . £17.00

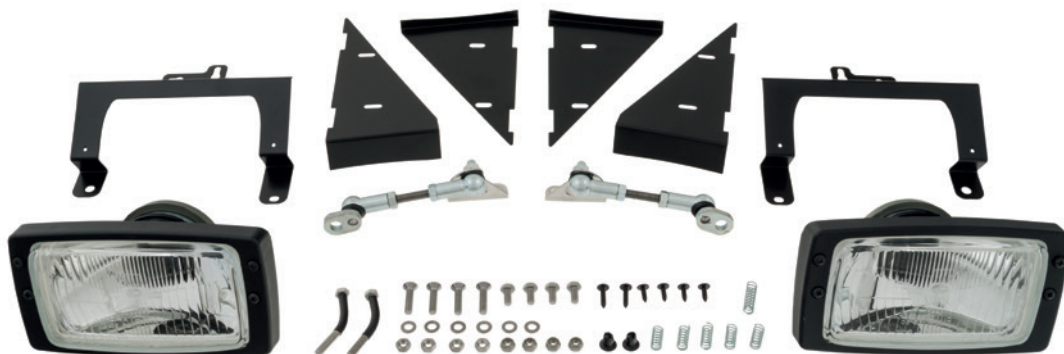

Low pro lights, 1989-97 . . . . . MXV14051 . . £290.00

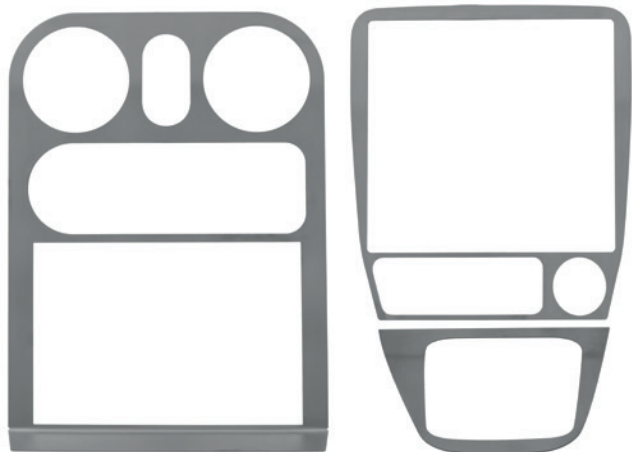

MXV14350

MXV14351

Tombstone cover, stainless steel, 1989-97 . . . . . MXV14350 . . . £52.00  
 Radio surround, stainless steel, 1998-05 . . . . . MXV14351 . . . £62.00



Electric window switches, retro, 1989-97 . . . . . MXV14334 . . . £58.00

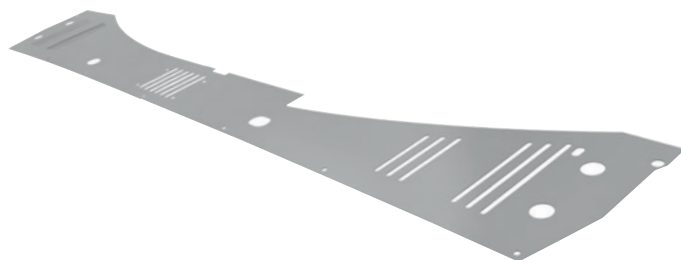

Windscreen scuttle panel, stainless steel, 1989-97 . . MXV14091 . . . £62.00

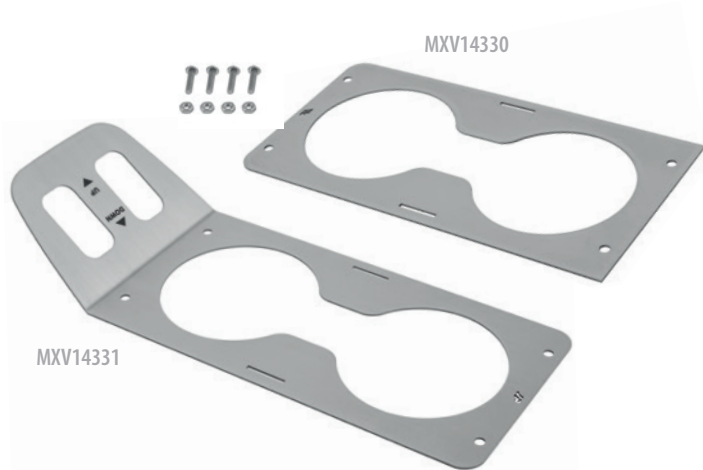

MXV14330

MXV14331

Cup holder, keyhole style, 1989-97 . . . . . MXV14330 . . . £22.00  
 Cup holder and window switches, 1989-97 . . . . . MXV14331 . . . £29.00



MXV14023

MXV14012

MXV14022

MXV14011

MXV14021

Tow hook, rear, polished, stainless steel, 1998-05 . . MXV14023 . . . £33.00  
 Tow hook, rear, polished, stainless steel, 1989-97 . . MXV14022 . . . £29.00  
 Tow hook, rear, red, 1989-97 . . . . . MXV14021 . . . £34.00  
 Tow hook, front, polished, stainless steel, 1989-05 . MXV14012 . . . £27.00  
 Tow hook, front, red, 1989-05 . . . . . MXV14011 . . . £34.00

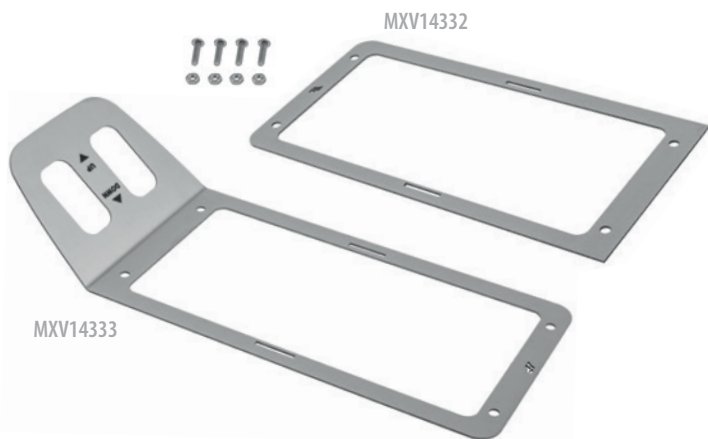

MXV14333

Ashtray surround, stainless steel, 1989-97 . . . . . MXV14332 . . . £20.00  
 Ashtray surround & window switches, 1989-97 . MXV14333 . . . £36.40



Oil filter removal tool, 1989-05 . . . . . MXV14122 . . . £18.00  
 (Mazda fitted two sizes of filter from 89-05 so you will receive both sizes)



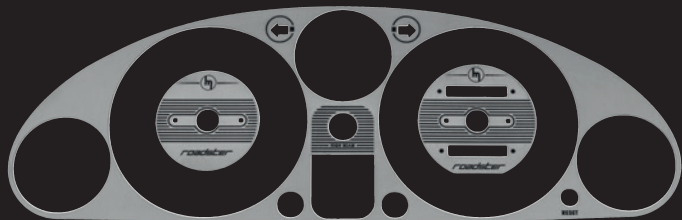

MXV14320

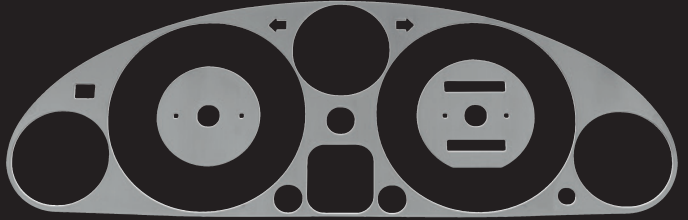

MXV14312

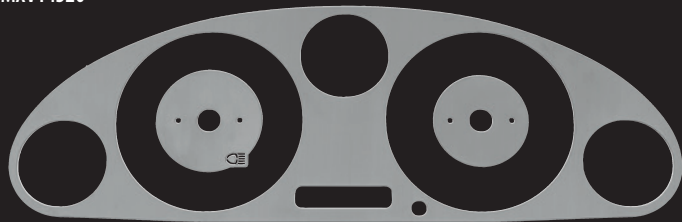

MXV14315

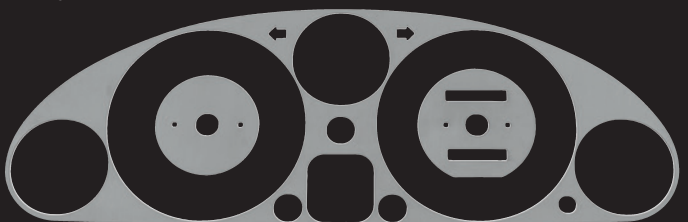

MXV14311

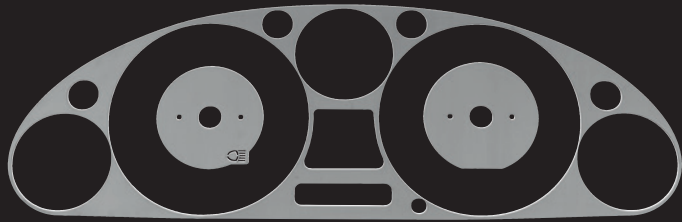

MXV14314

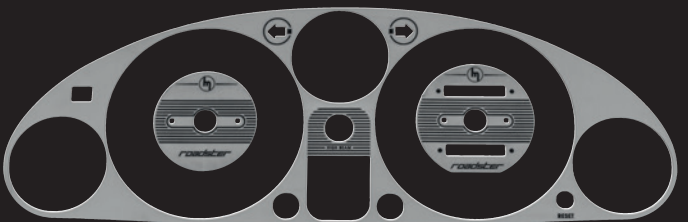

MXV14321

**Mk1 (1989-97)**

- Instrument cluster bezel engraved, 1989-93, 1.6 . . . MXV14320 . . . £37.00  
(Engraved stainless steel plates for tachometer & speedometer)
- Instrument cluster plain, 1989-93, 1.6 . . . . . MXV14311 . . . £30.00  
(Plain, comes with stainless steel plates for tachometer and speedometer)
- Instrument cluster plain, 1994-97, 1.8 . . . . . MXV14312 . . . £30.00  
(Plain, comes with stainless steel plates for tachometer and speedometer)
- Instrument cluster engraved, 1994-97, 1.8 . . . . . MXV14321 . . . £37.00  
(Engraved stainless steel plates for tachometer and speedometer)

**Mk2-2.5 (1998-05)**

- Instrument cluster plain, 1998-05 . . . . . MXV14315 . . . £43.70  
(Stainless steel, plain but thicker for better support if doing a custom LED install or chrome rings)
- Instrument cluster plain, 1998-05 . . . . . MXV14314 . . . £30.00  
(Stainless steel, plain, comes with plates for tachometer and speedometer)



MM900-136



**EXEDY STOCK CLUTCH KIT**

Mazda used Exedy clutches as OEM; these are the same replacement clutches. Includes; Friction disc, pressure plate, pilot bearing, release bearing and a clutch alignment tool.

**Mk1-2.5 (1989-05)**

Clutch, OEM replacement, 1989-05, 1.6 . . . . . MM900-135 . . £95.60  
 Clutch, OEM replacement, 1994-05, 1.8 . . . . . MM900-136 . £122.50

**Mk3 (2005-15)**

Clutch, OEM replacement, 5 speed, 2005-15 . . . . . 900-137 . . . . £185.00  
 Clutch, OEM replacement, 6 speed, 2005-15 . . . . . 900-138 . . . . £280.00



**CLUTCH MASTER CYLINDERS**

**Mk1-2.5 (1989-05)**

Mk1-2.5 OE, LHD, 1989-05 . . . . . 902-300 . . . . £160.50  
 Mk1-2.5, aftermarket, LHD, 1989-05 . . . . . 902-630 . . . . £44.50

**Mk3 (2005-15)**

Mk3 OE, LHD, 2005-15 . . . . . 903-246 . . . . £123.70  
 Mk3, aftermarket, LHD, 2005-15 . . . . . 903-248 . . . . £67.80



**CLUTCH SLAVE CYLINDERS**

**Mk1-2.5 (1989-05)**

1989-90, aftermarket, to VIN 111969, . . . . . 903-150 . . . . £26.60  
 1990-05, aftermarket, from VIN 111970 . . . . . MXV8127 . . . . £43.00

**Mk3 (2005-15)**

2005-15, OE . . . . . 903-245 . . . . £53.50  
 2005-15, aftermarket . . . . . 903-247 . . . . £32.40

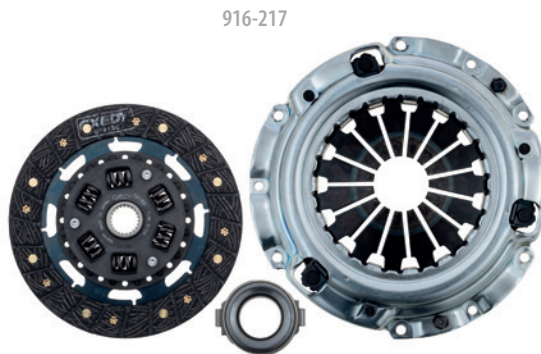

916-217



387-205



**EXEDY PERFORMANCE CLUTCH KITS**

Exedy racing clutches only use premium friction materials that are resistant to slippage and burst. Increased clamp loads give the necessary capacity to handle modified engines. Stage 1 uses organic material for street and light track use, for up to 30% more torque than stock. Drivability is similar to the stock clutch. Pedal efforts will be slightly higher because of the higher clamp loads. All of the clutch discs have spring centre dampers to reduce drivetrain shock.

Stage 1 organic clutch kit, 125 ft-lbs, 1989-93, 1.6. 916-215 . . . . £481.90  
 Stage 1 organic clutch kit, 180 ft-lbs, 2005-15 . . 916-217 . . . . £395.90  
 Alignment tool, 1989-05 . . . . . 387-205 . . . . . £7.90

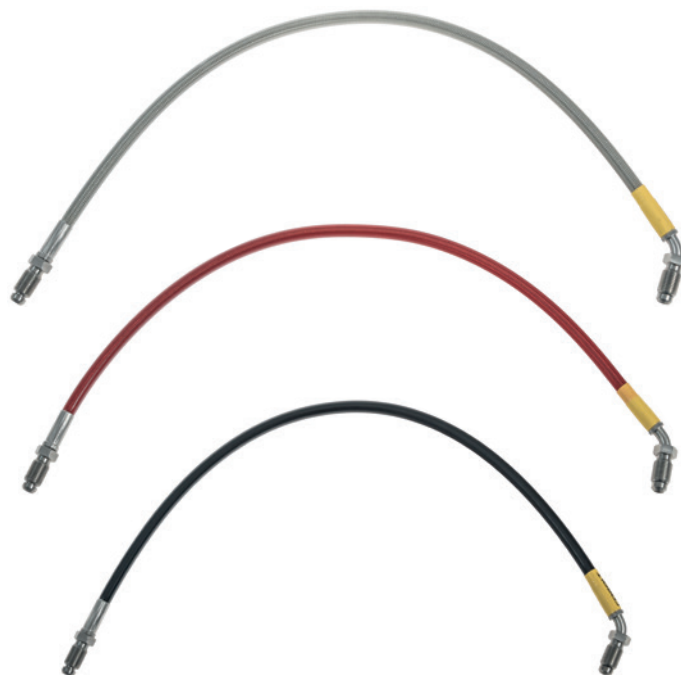

**BRAIDED CLUTCH LINES**

Specially made for Moss Europe by Mocal, these braided clutch lines replace both the factory copper hard pipe and 'pig tail' and the rubber flexi hose going into the slave cylinder itself, giving you a more responsive, easier to bleed clutch system.

Clutch hose, braided, clear, RHD, 1989-05 . . . . . 907-096C . . . £25.60  
 Clutch hose, braided, red, RHD, 1989-05 . . . . . 907-096R . . . £25.00  
 Clutch hose, braided, black, RHD, 1989-05 . . . . . 907-096B . . . £25.66

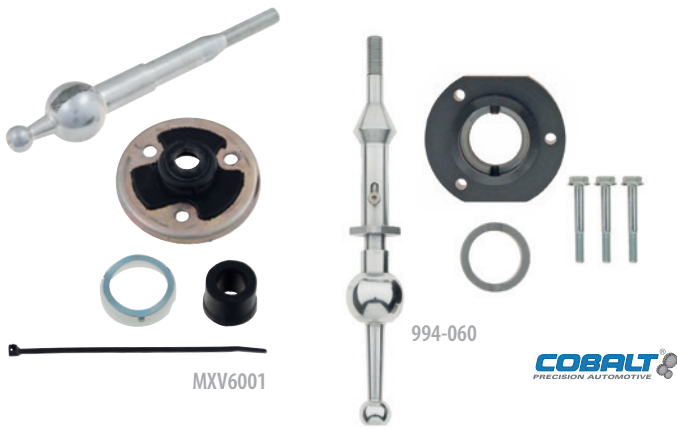

**COBALT SHORT SHIFTER**

The MX-5 has a great gearbox; Cobalt has succeeded in making it even sportier! Cobalt's zinc-plated billet steel sport shift kit reduces shift throw by 25% and can take the constant yanking and jerking unlike billet aluminium shifters that have been known to break. Shifting is even easier with a simple flick of the wrist. To ensure OEM quality and performance they supply a new dust boot, bushing and washers with their sport shifter. Complete with instructions and ready to install. Knobs sold separately, or reinstall your stock knob.

- Short shifter, 5 speed, 1989-05 . . . . . MXV6001 . . . . £55.70
- Short shifter, 6 speed, 2005-15 . . . . . 994-060 . . . . £144.80



**SHIFTER REBUILD KITS & SPARES**

Our rebuild kit is a mix of OEM Mazda and aftermarket pieces to keep the cost much lower than the full Mazda kit. If your shifter is getting sloppy, replace all your boots and bushings, clean the turret and refill with new fluid for super smooth shifting.

- Shifter rebuild kit, 5 speed cars only, 1989-97 . . . . 909-930 . . . . £43.30
- Shifter rebuild kit, 5 speed cars only, 1998-05 . . . . 909-932 . . . . £43.30
- Lower gear lever boot, 1989-05 . . . . . 770-823 . . . . £18.20
- Upper gear lever boot, 1989-05 . . . . . 994-010 . . . . £14.90
- Lower gear lever bush, 5 speed cars only, 1989-15 . 907-183 . . . . £8.10



**FIDANZA CAM GEARS**

Fidanza adjustable cam gears are made from 6061 T6 billet aluminium for strength and light weight. The gears feature 12 degrees of adjustments while most only feature 10, so you can tune your MX-5's engine for the best power output. CNC machined for precise fit and finish, and the outer gear is hard anodized for strength. Sold each.

Note: Due to the Cam angle sensor/VVT on the Mk2 & 2.5 (1998-05), these cam wheels can only be fitted on the exhaust cam on these models.

- Cam gear, Fidanza, aluminium, 1989-05, each . . . . 994-020 . . . . £187.00
- Cam gear, Fidanza, red, 1989-05, each . . . . . 994-021 . . . . £170.50



**UPGRADED SHIFTER REBUILD KITS**

Theses kits include an uprated lower bush from 5X Racing, which is made from much harder wearing bronze over the factory plastic piece, excellent longevity whilst still maintaining factory feel. Due to the boots being made from rubber, they tend to wear, letting heat and noise into the cabin and also reducing the accuracy of the gear levers throw, so why not replace them all at once, and whilst you're at it, clean out the turret and replace with new oil for super smooth shifting.

- Upgraded shifter rebuild kit, 5 speed, 89-97 . . . . 907-255 . . . . £61.20
- Upgraded shifter rebuild kit, 5 & early 6 speed, 98-01 . 907-257 . . . . £62.50
- Upgraded shifter rebuild kit, late 6 speed, 02-05 . . . 907-256 . . . . £70.00

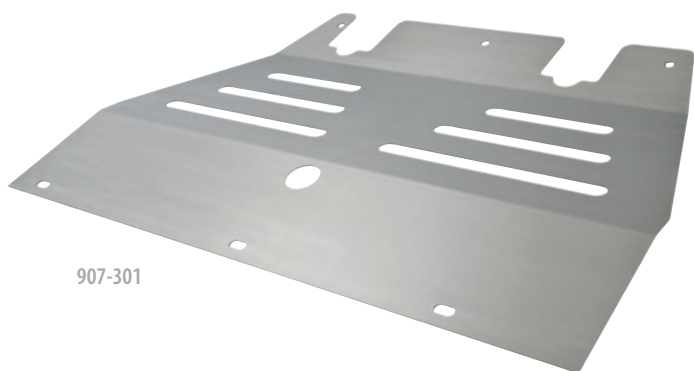

907-301



907-302



### SKID PLATES

The MX-5 comes with a flimsy plastic engine undertray that is prone to deterioration and cracking. Once this factory piece is compromised dirt, debris and excessive amounts of water can get on your engine and belts leading to increased maintenance. The other function of an engine undertray is to direct air through your radiator and not let it escape under them. Cobalt engineers have developed a replacement shield to protect your engine, radiator, and all other vital engine parts from damage. Using stainless steel construction to ensure it is a rock solid addition to your MX-5, the Cobalt engine shield will perform the same functions as your original undertray - only better. The Cobalt shield reuses your factory bolts and screws. Upgrade to the bright kit to really finish off the beautiful look. Kit includes zinc-coated metric hardware to replace those grungy OEM bolts.

- Skid plate/undertray, Cobalt, 1998-05 ..... 907-301.....£119.70
- Skid plate/undertray, Cobalt, 2005-15 ..... 907-303.....£145.40
- Fitting kit, undertray, 1989-05 ..... 907-302..... £12.00

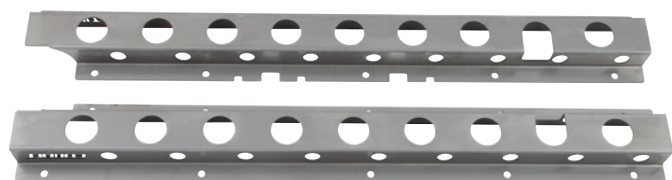

### FRAME RAIL BRACES

Now offering the best frame rail reinforcements for your MX-5. The factory rails on your MX-5 can be easily damaged over bumps or mistakes made whilst jacking and every time they develop a new bend, the car gets 'floppier'. The same happens with the chassis. A weak or flexible chassis shudders every time you hit a bump, whilst a stiff chassis gives your suspension a solid platform to work properly, leading to better, predictable handling and improved ride quality. With these brand new braces from Cobalt, you can resolve both issues. Just slide these sturdy braces over the factory frame rails and watch your car stiffen dramatically. The rails and fasteners are stainless steel to prevent corrosion, and are strong enough to act as jacking points.

- Frame rail braces, Cobalt, 1989-05 ..... 909-348. .... £135.00



MXVJR100



MXVJR1107



MXVJR310



MXVJR104



MXVJR1922



MXVJR311



MXVJR108



MXVJR2601



MXVJR502

## JAPAN RACING WHEELS

Japan Racing offers a wide range of high quality wheels, building a strong reputation as leaders in the aftermarket wheel market. Available in different colours, sizes, offsets, PCD's and also the option for custom PCD's. Fit all 1989-05 models.

- JR10, 15x7, ET30, 4x100/108, BF+ Machined... MXVJR100 .. £120.00
- JR10, 15x7, ET30, 4x100/108, MatBlk BzLip .. MXVJR104 .. £120.00
- JR10, 15x8, ET20, 4x100/108, BF+ Machined... MXVJR108 .. £128.00
- JR11, 15x7, ET30, 4x100/114, Flat Black. .... MXVJR1107. £120.00
- JR11, 15x8, ET25, 4x100/108, Flat Black. .... MXVJR1112. £128.00
- JR12, 15x7.5, ET26, 4x100/114, Gun metal. ... MXVJR1207. £128.00
- JR12, 15x8.5, ET13, 4x100/114, Gun metal. ... MXVJR1213. £135.00
- JR19, 15x8, ET0, 4x100, Gun Metal. .... MXVJR1921. £135.00
- JR19, 15x8, ET0, 4x100/114, Gold. .... MXVJR1922. £135.00

- JR26, 15x8, ET25, 4x100/108, Machined Sil ... MXVJR2601. £146.00
- JR29, 15x8, ET28, 4x100/108, Matt Black. .... MXVJR2905. £128.00
- JR3, 15x8, ET25, 4x100/108, Hyper Silver. .... MXVJR310 .. £135.00
- JR31, 15x7.5, ET20, 4x100, Black Machined ... MXVJR3100. £135.00
- JR3, 15x8, ET25, 4x100/108, Matt Black. .... MXVJR311 .. £128.00
- JR5, 15x7, ET35, 4x100, Gun metal. .... MXVJR502 .. £120.00
- TF2, 15x7.5, ET30, 4x100/114, Gloss Black ... MXVTF200. £128.00
- Hub Rings, JR wheels, 74.1-54.1, Alloy ..... MXVJRHUB. £20.00
- Hub Rings, JR wheels, 74.1-54.1, Plastic ..... MXVJRHUB1. £4.00



MXVJRHUB



MXVJRHUB1

### FLYIN' MIATA ANTI-ROLL BAR SETS

Anti-roll bars keep your MX-5's body under control when cornering, helping to keep it as flat as possible. Flyin' Miata anti-roll bars are set for neutral handling and are adjustable so you can tailor the handling to your driving preferences, with two settings on the front and three on the rear. Hot formed from 4140 CrMo spring steel, these are stronger than cold formed bars. Includes brackets and urethane bushings with waterproof grease.

Sizes:

- Mk1 1.6: Front bar: 22.2mm, Rear bar: 15.8mm.
- Mk1 1.8: Front bar: 25.4mm, Rear bar: 15.8mm
- Mk2: Front bar: 25mm, Rear bar: 16mm.
- Mk3: Front bar: 25.4mm, Rear bar: 19mm.
- Mk4: Front bar: 28.5mm, Rear bar: 15.8mm.

Mk1 1.6, 1989-93 .....	910-895.....	£297.50
Mk1 1.8, 1994-97 .....	910-896.....	£310.00
Mk2, 1998-05 .....	910-897.....	£312.00
Mk3, 2015-15 .....	910-898.....	£366.60
Mk4, 2015>.....	910-898.....	£366.60



910-897

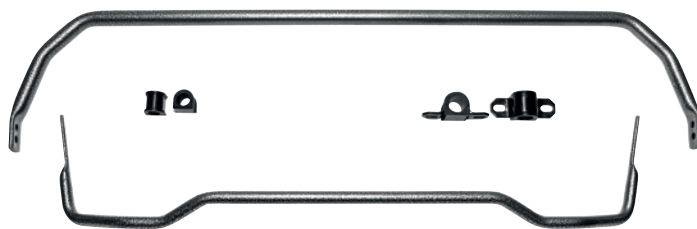

910-898

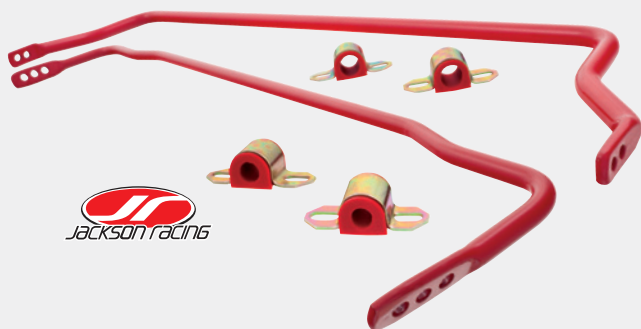

### JACKSON RACING ANTI-ROLL BARS

These anti-roll bars increase the handling performance of your MX-5 by reducing sway and body roll. Jackson Racing anti-roll bars are high-performance direct replacement upgrades for the factory bars. Both the front and rear bars are adjustable for fine-tuning. Polyurethane bushings and all mounting hardware are included. All Jackson Racing anti-roll bars come with easy-to-read instructions and a lifetime warranty against breakage.

Anti-roll bar, Jackson Racing, set, 1989-97 .....

MXV1184X. .£248.90



909-851



### COBALT ANTI-ROLL BAR DROP LINKS

These anti-roll bar links are heim-jointed steel with Teflon lining, and help set your car up for more neutral handling by increasing chassis deflection. Each set includes two heim-joint end links, all necessary spacers, Sold in sets of two, two sets required for the whole car. Adjustable. Sold as a pair.

Anti-roll bar links, front or rear, pair, 1989-97 ..	909-850.....	£74.60
Anti-roll bar links, front or rear, pair, 1998-05 ..	909-851.....	£72.10
Anti-roll bar links, front, pair, 2005-15 .....	909-852.....	£79.80
Anti-roll bar links, rear, pair, 2005-15.....	909-853.....	£78.20



### COBALT ANTI-ROLL BARS

The 3rd generation MX-5 handles well from the factory, but Mazda had to compromise in order to meet the expectations of all potential drivers. As a result, Mazda has left room for improvement even in suspension of cars with the factory Sport package. The addition of Cobalt hollow anti-roll bars will reduce your MX-5's body roll, making your MX-5 more responsive to turning, more settled in transitions, and more fun to drive. The Cobalt anti-

roll bar sets stiffness has been carefully chosen to enhance handling and balance without ruining your ride quality. The rear bar is two position adjustable. Front bar diameter is 25mm and rear bar is 16mm.

Anti-roll bar, Cobalt, set, 2005-15.....

920-330..... £234.70

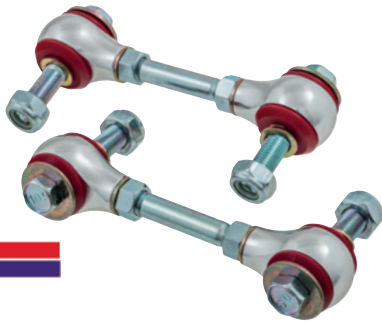

### RACING BEAT ANTI-ROLL BAR LINKS

A direct swap for the MX-5 factory links and provide the performance enthusiast the ability to set either front or rear anti-roll bars to a "neutral position" while the chassis is at ride height to avoid pre-loading of the bar. The experienced enthusiast may wish to purposely "pre-load" the bar to create a specific handling characteristic to induce either a mild understeer or over steer condition. The CNC-machined aluminium end housings are fitted with urethane bushings to further reduce flexing. Each set contains two (2) links to serve one (1) anti-roll bar. Sold as a pair.

Drop links, anti-roll bar, front, 1989-97 . . . . . 902-670 . . . . . **£99.00**



### ANTI-ROLL BAR BRACKETS - HEAVY DUTY

Performance driving can take it's toll on the factory sheet metal anti-roll bar brackets causing them to flex, twist and tear. In some instances, the addition of performance roll bar bars can exacerbate the problem. The cure is a pair of heavy gauge replacement steel mounting brackets. Made to fit in place of the original brackets these heavy duty replacements will not flex or twist and are finished in durable black powder coat.

Heavy duty brackets, anti-roll bar, 1989-05 . . . . 900-187 . . . . **£288.50**



I.L. MOTORSPORT

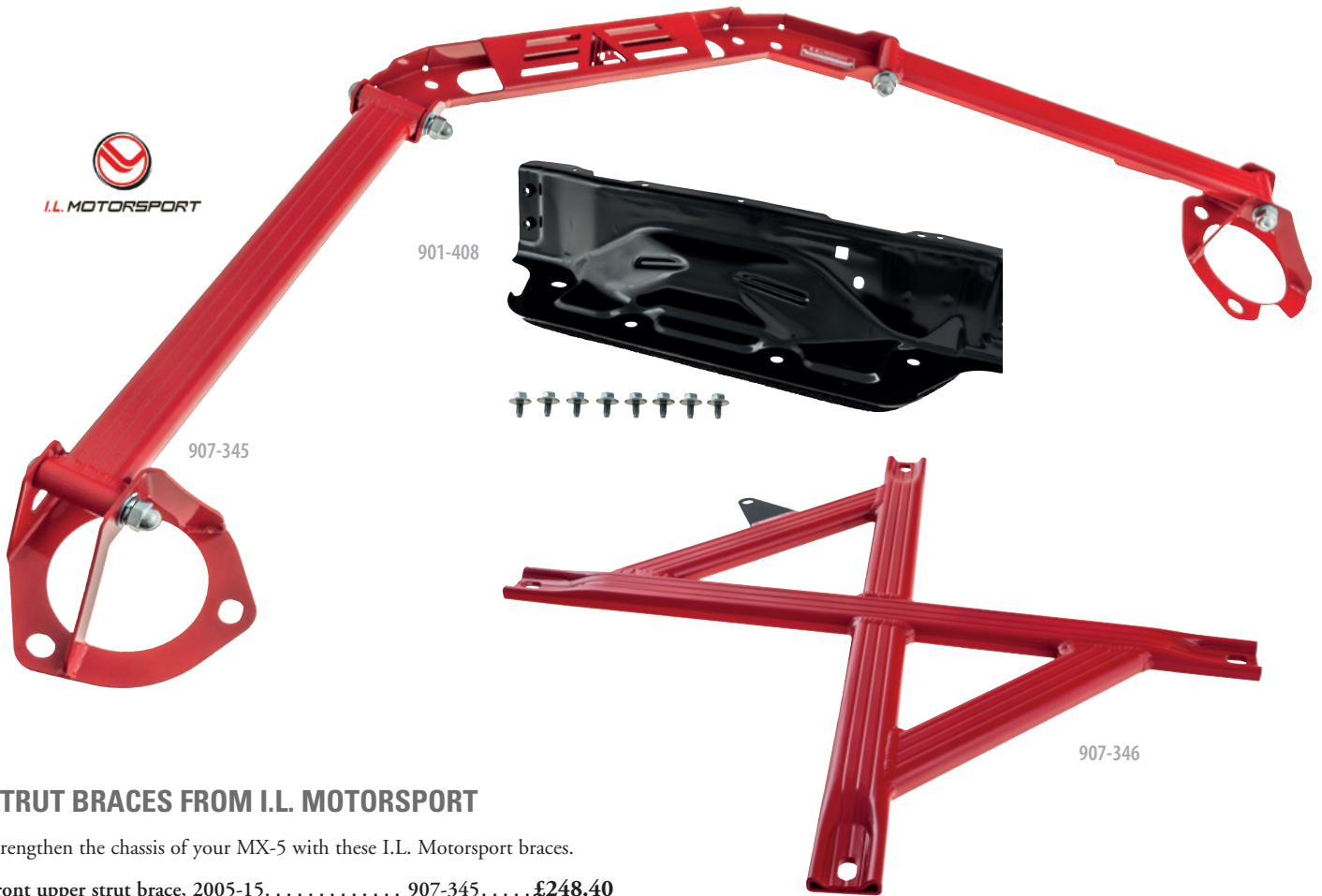

901-408

907-345

907-346

### STRUT BRACES FROM I.L. MOTORSPORT

Strengthen the chassis of your MX-5 with these I.L. Motorsport braces.

Front upper strut brace, 2005-15 . . . . . 907-345 . . . . **£248.40**  
 (If you don't already have a strut brace fitted you will require reinforcement panel 901-408).

Reinforcement plate for 907-345, 2005-15 . . . . 901-408 . . . . **£82.30**

Rear upper boot brace, 2005-15 . . . . . 909-420 . . . . **£136.80**

X brace front, 2005-15 . . . . . 907-346 . . . . **£95.30**

909-420



**REAR BOOT BRACE**

Engineered to work with and match Cobalt's 3-Point Front Shock Brace, this Cobalt Rear Brace is strong and beautiful. Using strong oval section stainless steel tubing this bar ties the tops of the shock towers together for better chassis rigidity. The welds are artfully done and the Cobalt logo is prominent yet understated. This design goes up then over to the shock towers instead of other designs that come forward into the boot space, keeping all of your boot storage open and available. Comes complete with instructions and all necessary hardware.

Rear boot brace, Cobalt, 1989-05 . . . . . 909-860. . . . . £81.20



**ENGINE STRUT BRACE 3 POINT**

Don't bother looking for a shock brace that compares with this one. Oval section stainless steel tubing is mated to beautifully crafted tower supports. The welds on this brace are a work of art! Aside from the best craftsmanship available, this brace actually works. Patterned after Le Mans style chassis bracing, this piece mounts in three places including a special bracket that secures it to the firewall. This ensures rigidity that cannot be duplicated by lesser quality braces that simply mount from shock tower to shock tower. Comes complete with instructions and all necessary hardware. Fits NA, Turbo & JR M45 Supercharged MX-5's! Note: Does not fit 90-05 MP62 superchargers. Does not fit 01-05 JR M45 superchargers.

Engine strut brace, Cobalt, 3 point, 1989-05 . . . 904-651. . . . . £149.20





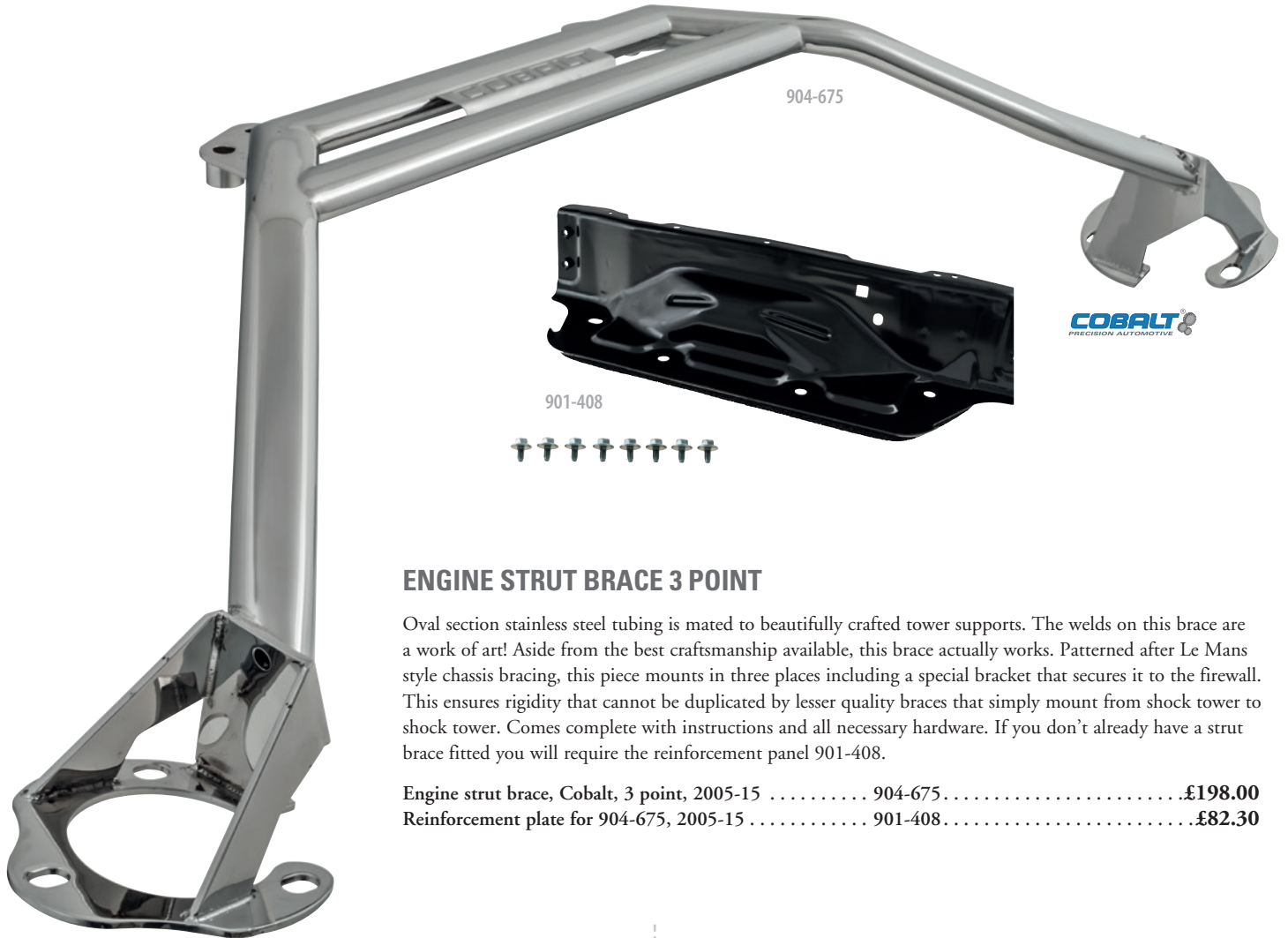

**ENGINE STRUT BRACE 3 POINT**

Oval section stainless steel tubing is mated to beautifully crafted tower supports. The welds on this brace are a work of art! Aside from the best craftsmanship available, this brace actually works. Patterned after Le Mans style chassis bracing, this piece mounts in three places including a special bracket that secures it to the firewall. This ensures rigidity that cannot be duplicated by lesser quality braces that simply mount from shock tower to shock tower. Comes complete with instructions and all necessary hardware. If you don't already have a strut brace fitted you will require the reinforcement panel 901-408.

Engine strut brace, Cobalt, 3 point, 2005-15 .....	904-675 .....	£198.00
Reinforcement plate for 904-675, 2005-15 .....	901-408 .....	£82.30



**FRONT LOWER & REAR LOWER BRACES**

These braces tie your lower body structure together for better handling and a smooth ride. Installation is simple and straight forward.

Front lower brace, Cobalt, 1989-97 .....	MXV1123X ..	£29.60
Rear lower brace, Cobalt, 1989-97 .....	MXV1124X ..	£29.40



**DELTRIN DOOR BUSHES**

This is one of the easiest and lowest cost ways to add chassis stiffness and reduce door rattles. When your door closes the latch holds it shut but there is also the metal cup on the door that fits around a bushing. This makes your door part of the structure of the chassis. Changing out your old, soft, rubber, factory bushings for a set of these delrin replacements stiffens the car and greatly reduces rattles.

Derlin door bushes, Cobalt, 1989-on .....	910-803 .....	£25.00
---	---------------	--------



MXVZETA



**MEISTER SUSPENSION**

MeisterR coilovers are one of the biggest names in aftermarket coilovers for the MX-5, combining build quality, good looks, and excellent performance, all at a sensible price. With 32 way damping adjustment, and separate ride height and preload ability, you really won't find a better coilover for your money, supple during normal driving and coming alive when the driving is more spirited.

**Mk1-2.5 (1989-05)**

- MeisterR Zeta CRD, 1989-05 . . . . .MXVZETA . . . . .**£856.10**  
(spring rate: 6kg/mm F, 5kg/mm R)
- MeisterR ClubRace, 1989-05 . . . . .MXVCLUB . . . . .**£963.20**  
(spring rate: 12.5kg/mm F, 7kg/mm R)
- MeisterR Zeta CRD, 2005-15 . . . . .MXV3ZETA . . . . .**£829.00**  
(spring rate: 7kg/mm F, 5kg/mm R)

**Mk3 (2005-15)**

- MeisterR ClubRace, 2005-15 . . . . .MXV3CLUB . . . . .**£1,048.90**  
(spring rate: 10kg/mm F, 6kg/mm R)

**Mk4 (2015 on)**

- MeisterR Zeta CRD, 2015-on . . . . .MXV4ZETA . . . . .**£888.20**  
(spring rate: 7kg/mm F, 4.5kg/mm R)
- MeisterR ClubRace, 2015-on . . . . .MXV4CLUB . . . . .**£1,048.90**  
(spring rate: 10kg/mm F, 6kg/mm R)



MXV4CLUB



903-971

903-972



**MAZDASPEED ENGINE MOUNTS**

Competition parts that were once only available to the MX-5 racing community are now available through Moss Europe. Higher horsepower and aggressively driven MX-5's will benefit from these rubber mounts that are 40% stiffer than stock. Engine mounts will keep everything in line by minimize flexing. This will allow the most power possible to reach the rear wheels. Sold each.

- Engine mount, uprated, each 1989-05. . . . . 903-971 . . . . .**£45.60**
- Differential mount, uprated, each, 1989-05. . . . . 903-972 . . . . .**£74.70**



**BUMP STOP AND COVER**

This bump stop kit includes a universal bump stop with a unique tapered bore. This means it is suitable for all types of shock absorber with rod diameters of anything from 10-22mm. In addition it includes a durable shock absorber cover with ties to secure it to the shock absorber body. This will protect the central shock rod from damage and corrosion. Kit includes 2 bump stops and 2 shock covers.

- Bump stop and cover, kit 1989-05 . . . . . 902-610 . . . . .**£39.90**

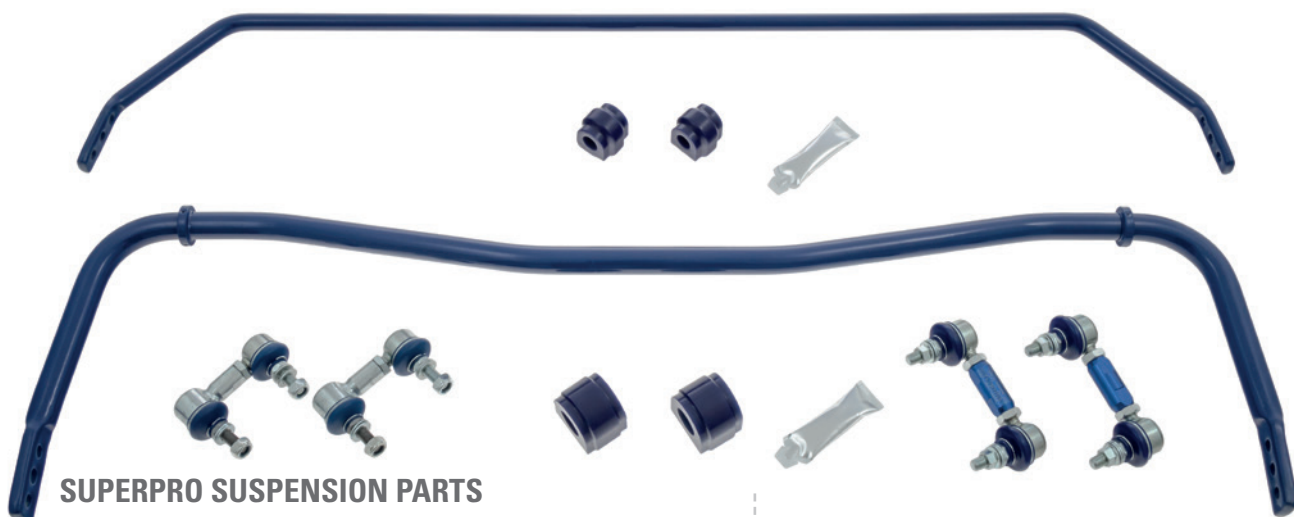

**SUPERPRO SUSPENSION PARTS**

The acclaimed revolutionary polyurethane suspension bushes from SuperPro are the first step to improving your suspension, ensuring better handling and steering response. Polyurethane bushes are 25-30% stiffer than the factory bushes and do not deteriorate in performance over time. The life of the bushes certainly will be longer and give an improved ride quality over worn rubber bushes, which are vulnerable to abrasion and prone to deterioration. These uprated polyurethane bushes give improved location without having a detrimental effect on noise levels or a harsh ride, and they won't be affected by ultra violet light, water, salt, oil or petrol.

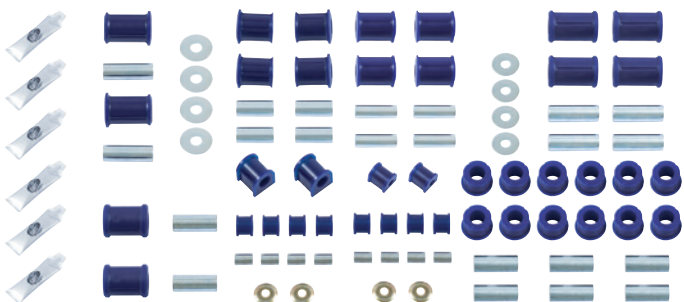

**SUPERPRO COMPLETE CAR SETS**

- Complete car set, 1989-05 . . . . . MXV8165 . . . £461.80
- Complete car set, adjustable, 1989-05 . . . . . MXV8166 . . . £551.70
- Complete car set, 2005-15 . . . . . MXV3040 . . . £650.00
- Complete car set, adjustable, 2005-15 . . . . . MXV3041 . . . £650.00

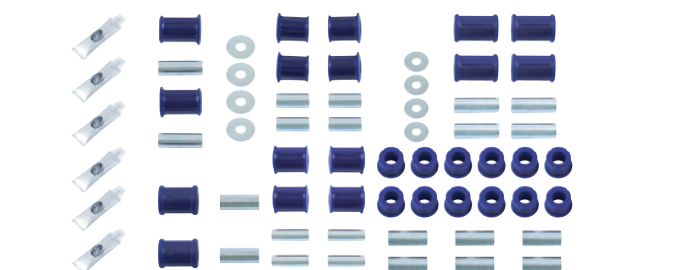

**SUPERPRO BUSH SETS**

- Complete running gear set, 1989-05 . . . . . MXV8167 . . . £372.20
- Complete running gear set, adjustable, 1989-05 . . . . . MXV8168 . . . £421.20
- Complete front bush set, 1989-05 . . . . . MXV8169 . . . £181.20
- Complete rear bush set, 1989-05 . . . . . MXV8170 . . . £280.70

- Anti-roll bar kit, 2015-on . . . . . MXV4154 . . . £636.00
- Anti-roll bar drop links, 1998-on . . . . . MX53400 . . . £105.00 (Mk2 & 3 F&R, Mk4 F only)



MXV8163

**SUPERPRO BUSHES**

- Void fillers, differential, 1989-05 . . . . . MXV8163 . . . £53.60
- Bush, anti-roll bar drop link, kit, 1989-05 . . . . . MXV8176 . . . £63.14
- Power steering rack mount, 1989-05 . . . . . MXV8178 . . . £27.70
- Manual steering rack mount, 1989-97 . . . . . MXV8179 . . . £33.40



MXV8222

**SUPERPRO ANTI-ROLL BAR MOUNTING BUSHES**

Suitable for 1989-05 models.

- Bush, Anti-roll bar mount, front, 15mm, pair . . . . . MXV8220 . . . £19.90
- Bush, Anti-roll bar mount, front, 18mm, pair . . . . . MXV8221 . . . £19.90
- Bush, Anti-roll bar mount, front, 20mm, pair . . . . . MXV8177 . . . £19.90
- Bush, Anti-roll bar mount, front, 22mm, pair . . . . . MXV8222 . . . £19.90
- Bush, Anti-roll bar mount, front, 24mm, pair . . . . . MXV8223 . . . £19.90
- Bush, Anti-roll bar mount, rear, 11mm, pair . . . . . MXV8224 . . . £20.90
- Bush, Anti-roll bar mount, rear, 12mm, pair . . . . . MXV8184 . . . £20.90
- Bush, Anti-roll bar mount, rear, 13mm, pair . . . . . MXV8225 . . . £20.90
- Bush, Anti-roll bar mount, rear, 14mm, pair . . . . . MXV8226 . . . £21.90
- Bush, Anti-roll bar mount, rear, 16mm, pair . . . . . MXV8227 . . . £20.90

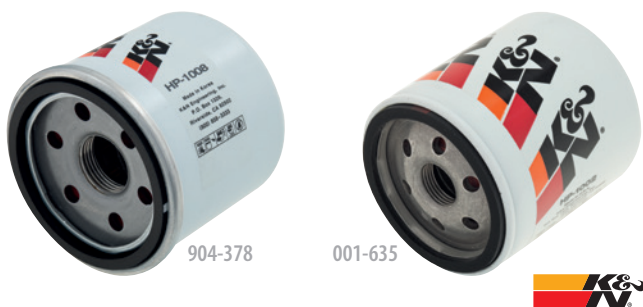

**OIL FILTERS**

K&N Oil Filter, you can expect heavy duty construction, high flow rates, & outstanding oil filtration.

- Performance oil filter
- Long life resin impregnated filtration
- High flow, high performance
- 1" welded nut for easy removal with wrench

Oil filter, K&N, 1989-05 ..... 904-378.....£14.00  
 Oil filter, K&N, 2005-15 ..... 001-635.....£16.60



**OIL FILTER ADAPTER**

A perfect solution for anyone that needs additional connections for gauge sending units. This adapter has three ports for sending units. All three ports will accept sending units with American 1/8" NPT (27 TPI) thread or metric taper M10 x 1.0 threads. Machined from aluminium, the adapter is highly polished and the package includes the O-ring seal, the oil filter nipple and tapered plugs for two of the three sending unit ports. Please note that sending units are not included - the sending units in the photograph are there to show how the adaptor can be used. Uses the stock type Mazda oil filter.

Filter adapter, 1989-05 ..... 904-565.....£57.70



**AIR-OIL SEPARATORS**

Your MX-5 isn't running as cleanly as you thought, and this air-oil separator from Moroso is what you need to clean it up. The factory designed the engine to vent excess vapours and oil back into the intake manifold, causing oil deposits that gunk up the intake and the valves, and crankcase gases which could cause detonation. Plumbing this air-oil separator into the PCV system captures the oil and moisture and contains it in this great looking billet canister.

Air-oil separator, Moroso, alloy, 1989-97 ..... 909-630.....£174.00  
 Air-oil separator, Moroso, black, 1989-97 ..... 909-631.....£174.00



**REMOTE FILTER RELOCATION KIT**

This kit makes oil changes a snap. The factory oil filter is buried underneath the inlet manifold and can be tricky to reach. This remote mount relocates the filter to the firewall area, allowing you to change your oil without an arm covered in scratches and scrapes. Please note: This kit is designed to be bolt on for LHD models, but can be used on RHD models by simply drilling the mounting holes.

Filter Relocation Kit, 1989-05..... MXV1218X..£147.60

### MK4 UPGRADES

A popular dual tip design is now available from the Cobalt brand! These new exhausts feature a laser-etched Cobalt logo on the tips and carry over all the same great features and sound from the single tip design:

- 1.2 mm thick polished stainless steel used for exhaust shell, tips, and piping
- Exhaust packing is a combination of stainless steel wool and fibreglass for a perfect sports car sound that is never intrusive, raspy or drones on the highway
- Stainless steel used for inner core and perforated tubing
- 2-3/8" Pipe diameter
- Entire exhaust completely polished to a mirror shine
- Sporty 3-1/2" insulated and polished exhaust tips
- Easy bolt-on design
- Gasket included
- 5-Year Warranty

Twin exit stainless steel silencer, 2016-21 . . . . . 910-620 . . . . . £245.00

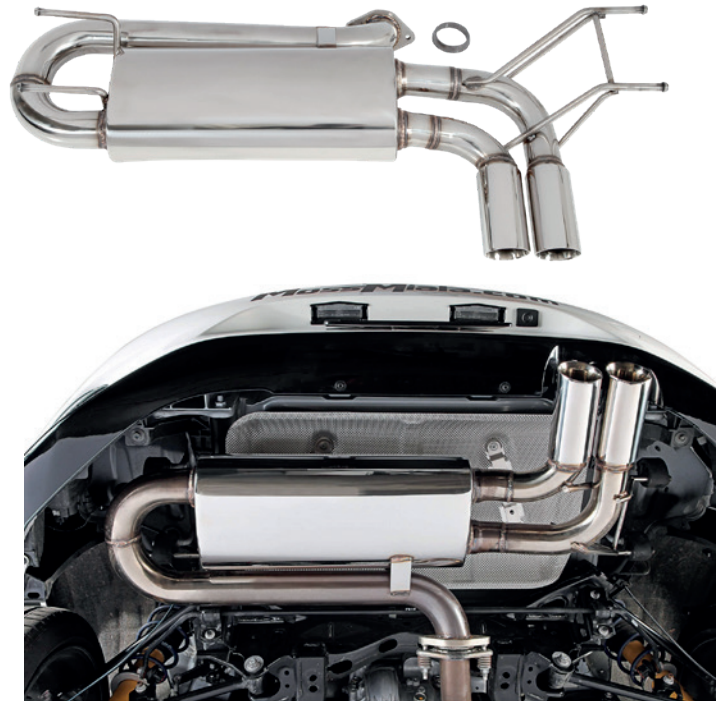

910-695

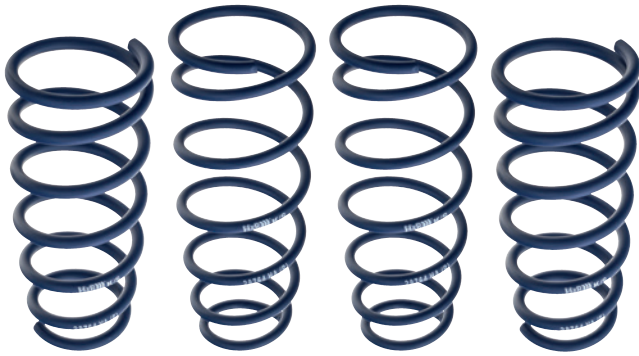

904-305

Fit 2016 onward models.

- Number plate relocation . . . . . 910-745 . . . . . £58.90
- Delrin door bushes, pair . . . . . 910-803 . . . . . £25.00
- Eye ball vents, satin, 3 required per car . . . . . 910-695 . . . . . £73.10
- Boot liner, factory . . . . . 910-658 . . . . . £88.80
- Lowering springs, H&R. . . . . 904-305 . . . . . £295.60
- Stubby aerial . . . . . 909-676 . . . . . £17.20
- Adjustable anti-roll bar links front. . . . . 909-854 . . . . . £105.50

### VODOO GEAR KNOBS

- Satin/pearl . . . . . 902-255 . . . . . £43.80
- Piano black . . . . . 902-257 . . . . . £43.80
- Textured black. . . . . 902-258 . . . . . £43.80
- Polished. . . . . 902-256 . . . . . £43.80
- Aluminium. . . . . 902-259 . . . . . £43.80



910-658



902-255



902-257



902-258



910-803



902-256



902-259



910-745

909-854





900-287



904-881



900-292



### TRACK DOG RACING FRONT SPLITTERS

Air Splitters are designed to help protect your front bumper and air dam. Modern bumpers are made from flexible urethane to allow flexing when bumped - but the painted surfaces are still vulnerable to scratches and scrapes. Air Splitters help protect your bumper by extending the protection around the front perimeter. The original Splitter is made from 1/8" thick, high-impact ABS plastic and the extreme version in 1/4". The top surface has a black texture finish, while the underside has a smooth finish that slides easily over steep approach angles.

- \*Fits with factory air dam/spoiler
- \*\*Fits with Mazdaspeed air dam/spoiler

<b>Mk1 (1989-97)</b>	
Extreme splitter, 1989-97 .....	904-881.....£120.70
Radical, 1989-97 .....	900-292.....£233.60
<b>Mk2-2.5 (1998-05)</b>	
Extreme, MK2, 1998-00 .....	900-287.....£130.30
Radical, MK2, 1998-00 .....	904-597.....£208.30
Splitter, original, MK2.5, 2001-05*.....	900-289.....£105.50
Splitter, original, MK2.5, 2001-05**.....	900-291.....£138.10
Radical, MK2.5, 2001-05 .....	900-293.....£228.00



906-334



906-347

### ENKEI WHEELS

When you demand performance plus great looks, Enkei delivers. Made with Enkei's MAT technology, these wheels are light but strong with plenty of clearance for large brake calipers. Spigot rings, hub caps and wheel nuts are not included. 15" wheels will not accept hub caps. All wheels have a centre bore of 73mm.

<b>Fits with factory air dam/spoiler</b>	
Enkei RPF1, 15x7", ET35, 4x100, 1989-05 .....	906-440.....£269.10
Enkei RPF1, 16x8", ET41, 4x100, 1989-05 .....	906-334.....£280.00
Hub Cap, Enkei RPF1, 16" only, 1989-05 .....	906-347.....£27.10



905-365



### R SPEED LIP SPOILERS

Stylish air dam captures the form and function of your MX-5. Molded from ultra tough polyurethane for strength and flexibility. The air dams not only look great but help your MX-5 stick to the road at speed. Parts supplied in ready to install black.

Front lip, R Speed, 1989-97 .....	900-969.....£188.30
Rear lip, R Speed, 1989-97 .....	905-365.....£171.60

(2 piece kit designed for single exit exhaust cars)



**MIRRORS**

Pick one of our three styles of mirror to suit your MX5. We offer Raydyot, Round and F1 Style mirrors. Available with Flat or Convex glass and different finishes.

Please note: Some cars may require the centre hole on the car widened to fit these mirrors. Supplied as pairs and with fittings.

- Door mirrors, chrome, round, convex, 1989-05 . MXV14421 . . . £46.60
- Doro mirrors, chrome, round, flat, 1989-05 . . . . MXV14423 . . . £46.60
- Door mirrors, Raydyot, satin, flat, 1989-05 . . . . MXV14424 . . . £60.00
- Door mirrors, Raydyot, polished, flat, 1989-05 . . MXV14425 . . . £66.00



**TSI'S**

We have taken our favourite turn signal intakes and made them even better! We have improved the design for excellent fitment. We've also improved the finish; they are now a smooth black finish ready to bolt on. If you do intend to paint match to your car we still recommend professional prep and paint work. Replace your front turn signals with a pair of these clever intakes that supply cool air into your engine compartment. Please Note: For use in Europe the sidelights will need relocation, or use the Switchback LED's instead.

- TSI's, 1989-97 . . . . . 903-202 . . . . . £66.00
- Switchback LED's, for TSI's, 1989-97 . . . . . GLB382MX . . £25.10



**PROJECT M BOOT SPOILERS**

Project M - hand crafted, original designs for the MX-5 & Miata since 2009. Made in the UK.



- Boot spoiler, ducktail, 1989-97 . . . . . MXV16010 . . £127.50
- Boot spoiler, ducktail, 1998-05 . . . . . MXV16020 . . £127.50



904-545



239-812

**Indoor Satin Stretch Cover**

Satin Stretch custom car covers are made for Mx5 parked indoors, and for owners who want nothing but the best for their vehicle. The material has Lycra fibers that stretch in every direction, mirroring every perfect contour of your Mx5. The inner liner is the softest fleece available - specially designed not to rub off on convertible tops.

**Mosom Car Cover**

Mosom Plus is designed to protect your Vehicle in rain, light hail and snowy conditions. It is the only multi-layered, non-woven car cover available and is extremely durable. The Mosom car cover is designed to have the least number of seams to prevent water leakage. Fabrics are double stitched with wax-treated threads for maximum protection against leaks. The Mosom Plus car cover has a top polyester layer which acts as a UV inhibitor to protect your Vehicle from the damaging rays sunlight. The highly breathable inner layers of polypropylene and polyester provide water resistant properties for the cover. The innermost layer of polyester felt embraces your Vehicle's finish with a soft touch. With superb UV resistance, breathability, and water resistant features, the Mosom Plus car cover is an ideal choice for moderate and rainy weather climates.

**Outdoor Car Cover**

Silverguard Plus is a 300 Denier polyester material with a reflective, water resistant coating on the outer layer and a soft, non-abrasive layer on the inside. It is a great choice for areas that get harsh sunlight. It is not suggested for extreme rain, snow or ice. 300 Denier is a strong, heavy weave, which will not rip or tear easily. The silver coating on Silverguard Plus does an excellent job of reflecting sunlight, therefore protecting your top, rubber seals and interior from premature wear. The special soft inner layer pampers the most delicate paint finish.

**Stormproof Car Cover**

The culmination of over a decade of material engineering, it has only recently been possible to manufacture the microscopic yarns which go into this advanced micro-fiber cover material. Only one textile mill in the world was able to meet the specification - the results are truly a triumph for car cover users! Stormproof is uncoated and untreated, this means that even after months or years of use, it will retain the same properties as the day you purchased it! Stormproof has tested to be the most water resistant and (because there are no coatings) the most breathable car cover material you can buy. You can't go wrong with Stormproof.

**CAR COVERS**

Protect your MX-5 from all weather conditions with a protective cover from our range.

Car cover, outdoor, 1989-97 .....	238-802.....	£133.50
Car cover, Mosom, 1989-97 .....	238-800.....	£107.20
Car cover, Mosom, 1998-05 .....	238-810.....	£107.20
Car cover, Stormproof, 1989-97 .....	239-802.....	£209.10
Car cover, Stormproof, 1998-05 .....	239-812.....	£209.10
Car cover, Stormproof, 2005-15 .....	904-541.....	£209.10



238-810



MM900-990

**HARDTOP HOISTS**

Hardtop hoists allow you to lift and store your top out of the way above your car. To reinstall the hardtop, simply lower and attach. Fits hardtops for MX-5 Mk1, Mk2 & Mk2.5, may also fit other hardtops. Comes with strap harness, pulley assembly, screw in hook, rope cleat and wooden block with 2 screws.

Hardtop hoist, 1989-05 .....	238-810.....	£107.20
Hardtop hoist, 2006-15 .....	239-802.....	£209.10





904-885

904-886



903-275



**AFTERMARKET NUMBER PLATE KITS**

No one wants to run a front number plate; it ruins the lines of the MX-5. However, running into trouble by not having one sometimes doesn't seem worth it and we reluctantly give in to the law. The Flip Down number plate holder is the answer. It displays or retracts in one easy motion. When motoring, pull it out and flip it up; when you're at the car show, retract it for the clean look you admire. Now you can also choose a motorized version that operates with the push of a button from inside or outside your car.

- Manual flip kit, 1989-15 . . . . . 904-885 . . . . . £47.10
- Motorised flip kit, 1989-15 . . . . . 904-886 . . . . . £153.60
- Relocation kit, 2005-15 . . . . . 903-275 . . . . . £80.50



MXV13331



MX513331



**NUMBER PLATE PLINTH**

Number plate replacement plinth, ideal for converting imported cars or replacing cracked and broken plinths. Excellent quality injection moulded ABS plastic makes it strong and easy to fit.

- Number plate plinth, OE, 1989-97 . . . . . MXV13331 . . . £26.50
- Number plate plinth, OE, 1998-05 . . . . . MX513331 . . . £26.50



**STUBBY AERIAL**

If you've ever thought that tall whip-like antenna might be a hazard to unsuspecting eyeballs or a future casualty at a car wash, we've found a perfect solution. The stubby antenna is just 3.77 inches tall, super easy to install (unscrew the old, screw on the new stubby!), machined from billet aluminium and then powder coated for durability, and will not affect radio reception or interfere with satellite radio services. It blends in perfectly with your MX-5's sporty lines but you will notice it every time you look at your Mazda.

- Aerial, stubby, 1989-on . . . . . 909-676 . . . . . £17.20



**SHORT RAKE AERIAL**

Our MX-5's are small and the antenna should be too! Update your MX-5's look with a shorty raked antenna. At just 7" long, the black mast sits at a raked angle, and is easily unscrewed for removal if you have a car cover without a hole. Antenna is wired for power but you may get less radio reception than the stock tall mast antenna.

- Aerial, short rake, 1989-05 . . . . . 906-185 . . . . . £38.90



**REPLACEMENT RUBBER AERIAL**

A practical replacement for the factory antenna. Includes a 54" lead.

- Aerial, rubber, 1989-05 . . . . . 900-716 . . . . . £14.90



648-200



648-205



648-215



648-220



648-210



903-983

### OE BADGES

Genuine badges from Mazda Japan add style to your MX-5. Our supercharged badges let others know your MX-5's serious.

#### Genuine Mazda

- Rear badge, red, Roadster, 1989-97 . . . . . 648-200 . . . . . £24.70
- Rear badge, black, Eunos, 1989-97 . . . . . 648-205 . . . . . £32.60
- Rear badge, black, Roadster, 1989-97 . . . . . 648-215 . . . . . £24.30
- Rear badge, black, Roadster, 1998-05 . . . . . 648-220 . . . . . £19.20

- Rear badge, Supercharged . . . . . 648-210 . . . . . £18.40
- Mazdaspeed decal (measures 36" in length) . . . . . 903-983 . . . . . £20.10



### BICYCLE RACK

This universal bike rack installs in minutes and holds up to three bikes securely.

Bicycle rack . . . . . 648-200 . . . . . £24.70  
(Will not fit MX-5's with lip or wing style spoilers)



901-610



MXV1074X

### BOOT RACKS

Going away this summer? Then fear no more about lack of space by installing one of our stainless steel boot racks. Designed to be easy on/off and will not mark the bodywork. No drilling required.

- Boot rack, stainless steel, 1989-97 . . . . . MXV1074X . . £264.70  
(No drilling required)
- Boot rack, stainless steel, retro, 1998-05 . . . . . MXV1075X . . £231.70  
(No drilling required)
- Boot rack, stainless steel, 2005-15 . . . . . 901-610 . . . . £173.30  
(Not suggested for use with PRHT. Will not work with spoiler. No drilling required)

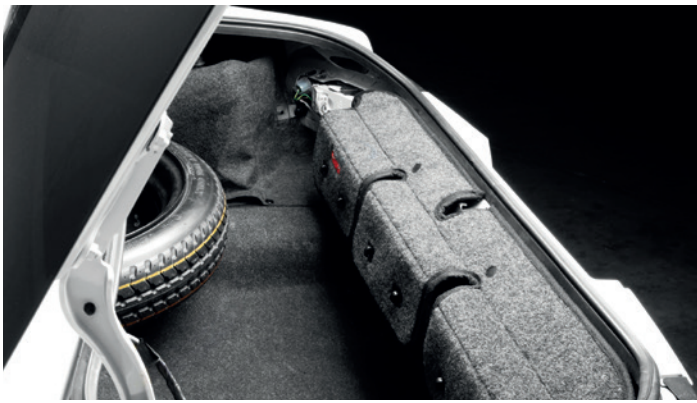

**BOOT LID POCKET POD**

Ingenious design mounts inside your boot and contains 3 storage pockets. Constructed of durable nylon, each pocket system has 2 locks to keep items stowed securely. The Pocket Pod™ is a great place to keep necessity items such as an umbrella, jumper cables and car care accessories.

Pocket pod, 1989-97 . . . . . 906-240 . . . . . **£125.00**



**HEATED BLANKET**

The Comfy Cruise 12 volt heated travel blanket is the ideal travel companion for all weather conditions. Offering both comfort and warmth, its 42" x 58" size is large enough for two people and is perfect for warming one bench seat or two bucket seats at a time. Features an 8 foot long fused cord and automatic temperature control. Made of 100% high quality polyester fleece. Great for cold winter morning starts or long hauls, the Comfy Cruise will provide warmth, whether it's plugged in or not.

Heated blanket. . . . . 002-842 . . . . . **£38.20**

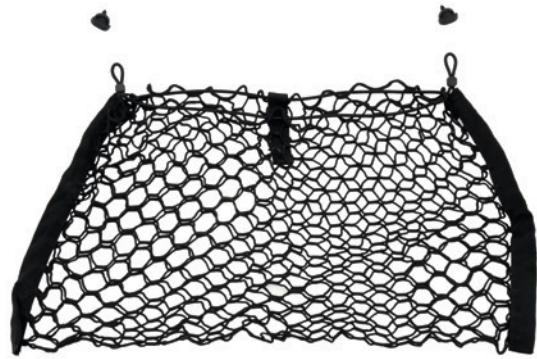

**CARGO NET**

Trap small items that tend to roll around your boot in a cargo net. Attaches to the boot lid hinges and opens at the top for easy stuffing.

Cargo net, 2005-15 . . . . . 900-752 . . . . . **£76.90**



**BOOT POCKET POD**

Ingenious design mounts to underside of your boot lid and contains 3 storage pockets. Constructed of durable nylon, each pocket system has 2 locks to keep items stowed securely. The Pocket Pod™ is a great place to keep necessity items such as an umbrella, jumper cables and car care accessories.

Boot pocket pod, 2005-15 . . . . . 906-242 . . . . . **£136.50**  
(Fits soft top only)





**COBALT FUEL PUMP**

When you make more power, you need more fuel. In a standard normally aspirated car, the stock fuel pump delivers just enough, plus a little extra. As the pump ages, it may no longer be able to deliver its full rated capacity. When you add a super or turbocharger, you need more fuel at a higher pressure. Odds are that your stock pump will not meet this demand. The result is a dangerously lean running condition. There are plenty of generic pumps out there, but only the Cobalt high output fuel pump has been specified to deliver the correct amount of fuel. The Cobalt pump is a direct in tank replacement. If you are installing a super or turbo charger, we highly suggest replacing your stock fuel pump at the same time.

Fuel pump, Cobalt, high flow, 1989-97 . . . . . 989-206. . . . £130.00



**FUEL CAP**

Put this fuel cap on and never take it off! This cap has a special spring-loaded door, which allows you to fuel up without removing the cap.

Fuel cap, Permagas, 1989-97 . . . . . MXV1175X. . . £12.30



907-172



907-173

**DDM WORKS GAUGE HOLDERS**

Add a little style and function to your MX-5! Three upgrades in one - this piece allows for installation of 3 gauges, a strong radio mounting area and your choice of stainless steel or black powdercoat material for a seamless look. Made of 304 stainless steel it is as strong as it is beautiful. Holes fit any standard 2 1/16" gauge and a spot to securely hold your radio in place. Fits all 89-95 MX-5's and 96-97 MX-5's with the factory upgraded radio. (Some aftermarket head units may require some modification of the radio surround for proper fitment).

Radio and gauge holder, stainless steel. . . . . 907-172. . . . £93.60  
 Radio & gauge holder, black powdercoat. . . . . 907-173. . . . £93.60

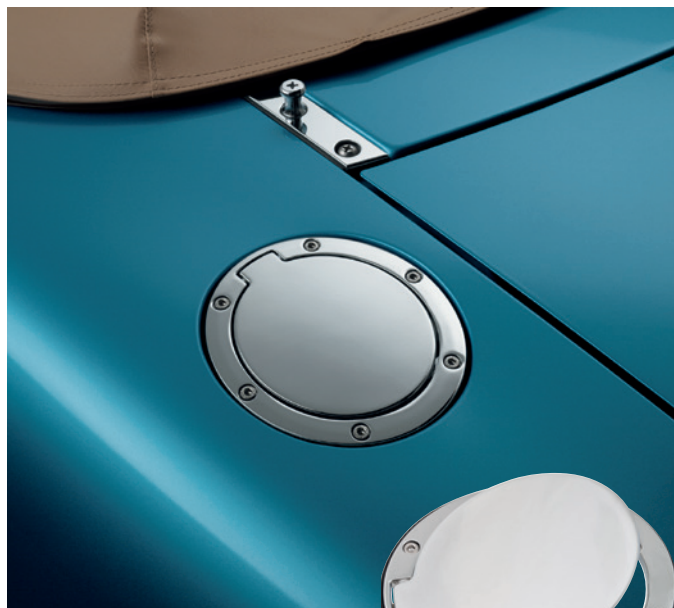

904-172

**CHROME FUEL LID KITS**

Add the look of smart, handcrafted, one off race parts to your MX-5. These fuel door kits are as functional as they are stylish. Installed in around 10 minutes using existing mounting holes. Uses the original remote filler lid opener. Instructions included.

Fuel lid kit, chrome, 1989-97 . . . . . 904-172. . . . £79.40  
 Fuel lid kit, chrome, 1998-05 . . . . . 904-171. . . . £74.00



**TRACK DOG RACING GAUGE HOLDERS**

The MX-5 has a perfect spot below the centre air vents to mount gauges. Now we offer this black plastic panel that fits perfectly into that DIN sized radio area. Compatible with both LHD and RHD models.

3 gauge panel, flat, 1989-97 . . . . . 904-430. . . . £41.70  
 3 gauge panel, angled, 1989-05 . . . . . 904-345. . . . £59.50



MXV18032



MXV18035

### MK1 DOOR TRIM PANELS

These handmade door panels are made from 2.4mm automotive hardboard; foam is added and then covered in vinyl as per Mazda original design. All relevant holes are pre-cut. These door panels are supplied with fitting instructions. Also available in other colours. Please enquire.

- Door panels, black, 1989-93 . . . . . MXV18032 . . **£112.60**
- Door panels, black, 1993-97 . . . . . MXV18033 . . **£112.60**
- Door panels, black, 1993-97 . . . . . MXV18034 . . **£112.60**  
(To use with speaker surround)
- Door panels, black, 1993-97 . . . . . MXV18035 . . **£147.80**  
(Includes front pocket)
- Door panels, black, 1993-97 . . . . . MXV18036 . . **£167.30**  
(To use with speaker surround + pockets)
- Door panels, black, 1993-97 . . . . . MXV18037 . . **£225.70**  
(Includes front pocket next to speaker)



MXV18010

### MK1/2/2.5 COMPLETE DELUXE CARPET SETS

These deluxe carpet sets have been developed with several ideas in mind. Originally, the cockpit floor carpet produced by Mazda was a one-piece moulding, but these have been developed as a pair of moulded carpets to be easily fitted to both footwells. These footwell carpets have all the necessary shapes and holes to fit your floor panel exactly as if it were original. By making this kit in two parts, the fitting time is helped as you do not have to take out the dash assembly and also the carriage costs are significantly less. The second part of this kit is the moulded rear cockpit liner, which will fit exactly as your original and has all the necessary holes for the fasteners to fit into.

The third part of the kit is the bulkhead carpet, which fits behind the seats, and has cloth-bound edges where necessary. The whole kit, when fitted, will totally transform your interior.

Please Note: RHD only. These kits are supplied with a complete set of pictorial fitting instructions with a few tips on removal of your old carpets and fitting ideas of the new carpet set.

Also available in Powder Blue, Blue, Biscuit and Green. Please enquire.

- Carpet set, black, 1989-05 . . . . . MXV18010 . . **£340.00**
- Carpet set, red, 1989-05 . . . . . MXV18011 . . **£340.00**
- Boot carpet set, 1989-97 . . . . . MXV18020 . . **£295.10**



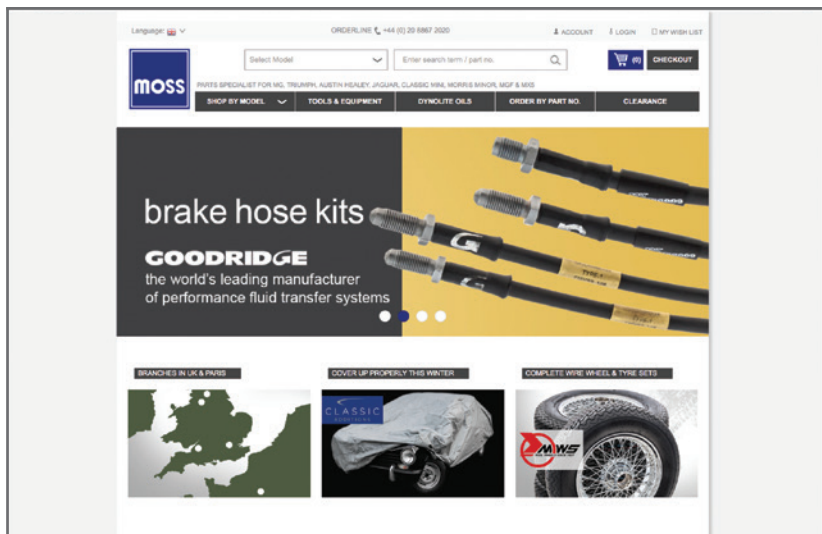

## HARNESS THE POWER

moss-europe.co.uk *"Available to you whenever you want!"*

Have easy access to everything in this catalogue, including multiple product images and our detailed schematics. Benefit from the latest parts information, availability and pricing.

Furthermore, you will have up to the minute information about our sale offers and clearance sale items.

All this and more...



Visit [moss-europe.co.uk](http://moss-europe.co.uk) and harness the power.





101-180

GAC0060

### ENGINE START BUTTONS

Get your car started right. Illuminated engine start button gives your vehicle that performance car feel. To prevent theft, the engine start button requires the use of your key to switch on the ignition and unlock your steering column. Start button can be installed in place of the cigarette lighter/power outlet. Complete with installation instructions and no drilling required.

- Engine start button, illuminated . . . . . 101-180 . . . . . **£18.10**
- Engine start button, Richbrook . . . . . GAC0060 . . . . . **£39.00**



### CHROME VENT RINGS

Supplied as a set of four, these stainless steel vent rings spice up your MX-5's interior with some flash and definition. Easily installed in minutes, these rings simply attach using an automotive quality 3M adhesive.

- Vent rings, chrome, 1989-05 . . . . . MXV1028X . . . **£16.40**
- (Sold as a set of four)



### DELTRIN WINDOW BUSHINGS

Over time window guide bushings wear out and the grease in the tracks get gunked up with dirt. If your manual windows are tough to roll up and down your bushes are probably worn. Replacing them is an easy half hour install. Our kit includes a new Delrin bushing for each door.

- Window bushing set, 1989-05 . . . . . 909-925 . . . . . **£20.00**
- (Sold as a pair)



MXV1189X

MXV1186X

### ROSEWOOD GEAR KNOB AND HANDBRAKE SLEEVE

Enhance your interior with this classic style wood gear knob and matching handbrake handle.

- Gear knob, 1989-15 . . . . . 909-925 . . . . . **£20.00**
- (Will not fit automatics)
- Handbrake sleeve, 1989-05 . . . . . 909-925 . . . . . **£20.00**



998-260

901-455



### SUN VISOR BLANKS

For many of us, the Sun Visors in the MX-5 are more of an obstruction than anything else. If you are like many owners who want to remove the sun visors but won't because of the unsightly holes left in the header rail, look no further. Moss has created these indestructible ABS Visor Caps. They install in minutes with a screwdriver.

- Sun visor blanks, chrome, 1989-05 . . . . . 998-260 . . . . . **£7.20**
- Sun visor blanks, black, 1989-05 . . . . . 901-455 . . . . . **£7.20**



### CUP HOLDER

Our aftermarket cup holder is a perfect fit for the MX-5 owner on the go. Textured to match your factory console, the cup holder features a rubber mat that fits under the cup holder to catch and retain spills. Install in seconds in place of your factory ashtray.

- Cup holder/coin tray, 1989-97 . . . . . MXV1170Z . . . **£20.30**



902-255



902-257



902-258



902-256



902-259



### VOODOO GEAR KNOBS

A Voodoo gear knob is the fastest and easiest mod you'll ever make to your car. Improved short-shifting capability is immediate! Voodoo gear knobs have been the enthusiast's first choice for driving enhancement since 1992. Each Voodoo gear knob is a 2 inch sphere of solid aluminium with a choice of finishes.

- Gear knob, Voodoo, satin/Pearl, 1989-15 . . . . . 902-255 . . . . . £43.80
- Gear knob, Voodoo, piano black, 1989-15 . . . . . 902-257 . . . . . £43.80
- Gear knob, Voodoo, textured black, 1989-15 . . . . . 902-258 . . . . . £43.80
- Gear knob, Voodoo, polished, 1989-15 . . . . . 902-256 . . . . . £43.80
- Gear knob, Voodoo, aluminium, 1989-15 . . . . . 902-259 . . . . . £43.80



MXV1138X



MXV1139X

### ARMREST PAD

Are you tired of resting your arm on that hard centre console? Our armrest pads install in seconds and offer added comfort.

- Armrest pad, vinyl, 1989-97 . . . . . MXV1138X . . . £26.70
- Armrest pad, leather, 1989-97 . . . . . MXV1139X . . . £44.70



MXV1016X

### FOOTWELL MATS

Save your carpet from wear and make the cabin that little more resistant to heat and noise with a set of footwell mats specifically designed for your MX-5. Sold as pair.

- Footwell mats, executive, black, RHD, 1989-05 . . . . . MXV1016X . . . £31.50
- Footwell mats, black, RHD, 2005-15 . . . . . MXV18031 . . . £38.10
- Footwell mats, black, RHD, 2015-on . . . . . MXV18030 . . . £38.10



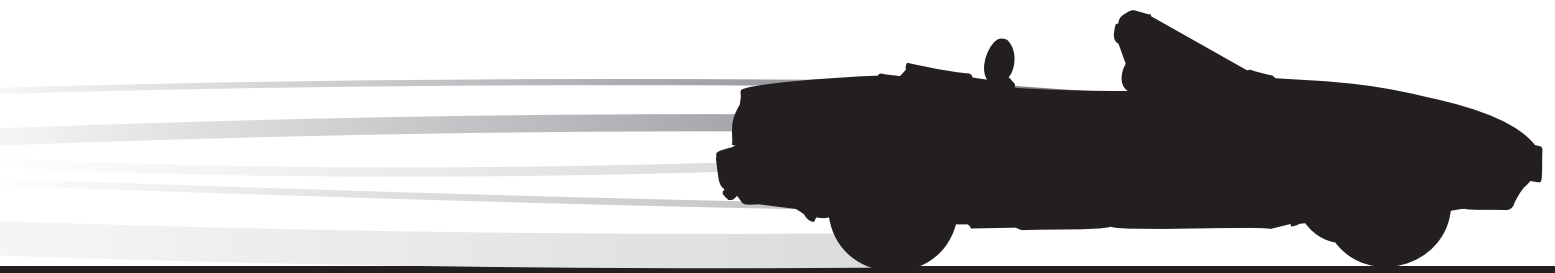

# MX-5 Restoration Parts

---



## Ordering Information

### Notification of prices

Due to the volatility of world markets and currency fluctuations the prices in this catalogue are subject to change. Moss make every attempt to keep prices competitive and stable, however in common with all other suppliers in our industry, we reserve the right to alter these prices without prior notice.

For the latest prices, please visit our website [www.moss-europe.co.uk](http://www.moss-europe.co.uk). All prices are per unit (unless otherwise stated) and include (UK) VAT at 20% (where applicable) and are correct at the time of going to print. Postage and packaging is not included. E&OE. Where the price is replaced with NCA this part is Not Currently Available. Please visit our website ([moss-europe.co.uk](http://moss-europe.co.uk)) or call our sales staff for the latest availability information or to enquire if we can offer an alternative part.

### Product supersessions

Moss Europe's policy is to detail the most up to date part information in our catalogues. Where possible parts are kept to original specification. However, in some instances we have to supersede to the most viable alternative product to maintain supply and keep cars on the road. Every effort is made to ensure high quality products.

### UK ordering

We accept orders by mail, telephone, e-mail, fax and on-line at [www.moss-europe.co.uk](http://www.moss-europe.co.uk). If you have the opportunity, we invite you to visit one of our branches. Remember, supplying details of your car, (i.e. engine, commission or Vehicle Identification Number (VIN) LHD or RHD, year of manufacture and any modifications) saves time and helps us to help you. Please inform us of your customer number, as this will speed up the processing of your order.

### Overseas ordering

We accept orders by mail, telephone, e-mail, fax and on-line at [www.moss-europe.co.uk](http://www.moss-europe.co.uk). If you visit the U.K. please come and visit one of our branches. When ordering, please ensure that you enclose full details of your name, address and customer number, plus details of your car (i.e. engine, commission or Vehicle Identification Number (VIN) LHD or RHD, year of manufacture and any modifications).

Please note: Overseas orders are often subject to local import duties, taxes and Customs clearance, which will need to be paid for at the point of entry. These charges are NOT included in the price of the goods or delivery prices. All relevant Customs forms and documentation needed to ensure the order arrives with the minimum of delay, will be included with your shipment. If you have any special requirements, please contact us to discuss them. Delivery charges are dependent upon the size and weight of the shipment. If a quotation is required prior to placing an order, please contact the export department at your chosen branch and they will be pleased to supply a full quotation.

### Parts back-order system

A back-order system is used when a part is not in stock at the time of ordering. If the item is expected to become available within 6 months, then it will be put on back-order, unless the customer instructs us otherwise. When we have the parts in stock, the back-order will be processed automatically and the item will be dispatched to the customer. If the particular part becomes No Longer Available (NLA) or does not become available within 6 months the back-order will be cancelled. If you are unsure when you placed a back-order contact your local branch.

### Dispatch & delivery methods

Orders for delivery in the UK may be dispatched by regular post for small/lightweight items, larger items may be dispatched via a courier. Please call us for the best delivery option for your order and the latest delivery prices. For delivery outside the UK we offer the following services.

- **Economy delivery (by road):** 2 to 5 days (approximately).
- **Express delivery (by air):** 1 to 2 days (Guaranteed) - next day service to most countries.
- **For small and low value orders we also use airmail.**

For these services, please ask for prices and the best delivery option when you place your order. Most deliveries (except airmail) are 'trackable', (inc: e-mail updates and internet access for selected carriers). Please remember, all carriage charges are dependent on weight band, volume, destination and delivery time. If a quotation is required prior to placing your order, please contact a member of the sales department. Alternatively, you can arrange your own delivery and dispatch.

### Windscreen delivery information

We always suggest that windscreens should be collected from one of our branches to ensure you are able to transport your glass with the utmost of care. However, we understand that this is not always possible.

To minimise the possibility of damage to the windscreen in the shipping process, it is now Moss Europe's policy to ship windscreens packed in a specially designed heavy duty 'Tri-Wall' cardboard box. The price of this box is £35.00 (Ex VAT), non-refundable and is not included in the price of the product. The crate's dimensions will also increase shipping costs, particularly in EU countries. The crate dimensions are 150cm x 33cm x 74cm. The maximum volumetric weight is 92kgs. For more information please contact your nearest Moss branch.

### Hazardous goods delivery information

At the time of going to print, Moss Europe Ltd conforms to international shipping regulations regarding packaging and transportation of Hazardous Goods by road and sea freight (only). Due to these international shipping regulations and licencing rules all goods deemed as Hazardous are currently available for shipping to the UK and Europe only. If you place an order containing Hazardous goods and your shipping address is not in the UK or Europe, we will not be able to ship this item to you. Please contact your local branch or visit our website [moss-europe.co.uk](http://moss-europe.co.uk) for the latest delivery information of Hazardous goods.

### Quotations & payment methods

We will be pleased to provide a full parts quotation detailing price, availability and relevant shipping costs. Payment may be made by cash, personal cheque (to the card guarantee limit), Certified Bank Draft, Sterling Travellers Cheques and credit or debit card including: Mastercard, Visa, Delta. If you intend to make payment by Cheque or Bankers Draft when using our fast

mail-order parts service, please confirm parts availability and carriage charges. We can accept payments using PayPal for website, email and phone orders.

### Value added tax (VAT)

Value Added Tax (VAT) at the current rate will be levied on all orders being dispatched to all countries within the European Community. EU countries may be charged at their local VAT rate, please contact us or see website for details. VAT is not charged on goods dispatched to countries outside of the EU. However, such orders are often subject to local import duty, taxes and Customs clearance, which MUST be paid by you at the port of entry. Such charges are not included in the cost of the goods or delivery prices.

### Exchange units

We are able to offer a full rebuild service on numerous major components in our product range. We offer this service as an alternative to direct replacement parts, or when a brand new item is no longer available. However, the continuity of this exchange scheme needs the understanding and co-operation of our customers in relation to several important points: It is important to remember that "rebuild" does not mean "brand new". Rebuilding a unit involves stripping, cleaning, inspecting and re-assembling the unit. During this process, parts showing signs of wear will either be completely replaced or suitably renovated. However, it is not always feasible for major sub-components to be replaced with brand new ones, for example, an exchange engine will not have a new block. Due to the nature of certain product lines, some items can only be offered on a "one for one" exchange basis. This effectively means that you must offer us a viable unit before we can release a fully rebuilt item from our stock. In some instances we can only carry out reconditioning of your own unit. Our staff will inform you if this is the case.

All exchange units are subject to a surcharge. This surcharge serves two purposes; firstly, it acts as an incentive for you to return your old unit, and secondly it provides us with financial cover if your returned unit proves unsuitable for exchange purposes.

Whether or not your returned unit is suitable for exchange purposes cannot be ascertained until it is made available to us for inspection. As a general rule, suitable for exchange basically excludes any items that are beyond reasonable repair (e.g. crankcases pierced by a connecting rod) or units irrevocably damaged. We are also unable to accept units unless they are returned in whole, complete form (i.e. differential units which are returned partly stripped with no bearings and all the shims missing are not generally accepted), nor do we accept a "box of bits".

Surcharges will only be refunded once our core department has passed the item as serviceable. Under no circumstances can any exchange unit be shipped overseas until we receive your original unit. We have predetermined prices for our exchange units based on our experience of repair costs for a gearbox, axle or engine. Occasionally, however, the damage to the unit is so great that we will contact you before beginning work on your unit to advise you of any additional cost that may be incurred during the rebuild of the unit. We can return the unit (at your cost) if this proves unacceptable.

### 'Old unit' returns

Exchange items including reconditioned engines are subject to a surcharge that is refunded when a rebuildable unit (core) is returned. When you receive the rebuilt unit, attached to it will be a Core Return Authorisation Tag. This tag must be removed from the rebuilt unit and attached to the returned core in order to receive credit. Cores must be returned within 90 days of purchase in the original box, carton or engine cradle supplied with the rebuilt unit. Cores must be shipped clean and empty of fluids. Cores must be complete, assembled and rebuildable to receive credit or refund. You must pay all shipping charges for the return of the core and these charges are not refundable.

### Warranty

All parts are warranted against defects in materials and workmanship for a period of twelve (12) months from the date of purchase. The warranty does not cover failure resulting from incorrect installation or misuse; failure during any competition, motorsports or track events; failure of any, or caused by any, related component. The warranty does not cover labour charges, nor will a warranty settlement be greater than the cost of the original component. Should you need to make a warranty claim, please contact us immediately at the branch of purchase. We will then advise you as to the best course of action. With all warranty claims a copy of the original purchase invoice must be produced.

### Warranty returns

Parts that fail in use may be returned for 12 months from the date of purchase. Returns must be accompanied by the original invoice - no warranty claims will be paid without a copy of the original invoice. Return freight will be reimbursed. Electrical parts returned for warranty will be tested and if found functional, no return credit will be given and the part will be returned. Reimbursement is made by the original payment method. Complete the return form included in each order, pack the items securely and use the shipping return label supplied.

### Non-warranty returns

All uninstalled parts, in their original packaging may be returned within 90 days for any reason. A copy of the original invoice or the picking label (which is generally attached to the original packaging) must accompany the return. Return freight is paid by the customer. If the return is due to our error, the return freight will be reimbursed. Parts returned outside of this policy or in non-resalable condition may not be accepted or may be assessed a 15% handling fee. Reimbursement is made by the original payment method. Complete the return form included in each order, pack the items securely and use the shipping return label supplied.

### Customer service

We value your custom and wish to ensure that you receive the very best service. Every effort will be made to provide you with Quality Parts and Expertise in a relaxed, helpful and friendly manner. Should you consider the service you receive from us to be unsatisfactory, or you have any problems with the part(s) purchased, please advise a member of the sales team at the originating branch. If the matter is not resolved to your satisfaction, please e-mail our Customer Services Department at [customerservices@moss-europe.co.uk](mailto:customerservices@moss-europe.co.uk) or write to: **Customer Services, Moss Europe Ltd Unit 16, Hampton Business Park, Bolney Way, Feltham TW13 6DB England.** *We will do our very best to resolve the issue.*

### British Motor Heritage

Moss Europe Ltd is a British Motor Heritage approved specialist. Our agreement with British Motor Heritage allows us the use of marque logos and some of the artwork contained within this catalogue.



## A Brief History

Mazda Motor Corporation started as the Toyo Cork Kogyo Co. in Hiroshima, Japan in 1920. In 1931 it transferred its manufacturing from machine tools to vehicles with the introduction of the Mazda-Go autorickshaw. In 2007, Mazda produced almost 1.3 million vehicles for worldwide sales. Inspired by classic British sports cars of the 1960's (specifically the Lotus Elan) Mazda debuted the MX-5 at the 1989 Chicago Auto Show. A two-seat sports car the MX-5 was conceived as a small roadster, with light weight & minimal mechanical complexity, whilst being technologically modern & reliable. Having sold over 1 million MX-5's worldwide, the honest little Mazda has not just reinvigorated the global sports car market, but been a leader in it for over 30 years.

## What Model MX-5 Do I Have?

Understanding what the model designations mean and what model MX-5 you have can be confusing if you're new to the MX-5 world, luckily there are a few quick and easy ways of determining what model MX-5 you own.

### Mk1 (1989-97)

The most distinguishing and perhaps most loved feature of the first-generation MX-5 is the pop-up headlights, which were deemed to not meet pedestrian safety standards as the Mk1 was nearing the end of its production.

### Mk2 & Mk2.5 (1998-05)

Mazda had to ditch the pop-up headlights for the Mk2, however, this makes it decidedly easier to distinguish between the Mk1 and Mk2, however, telling the Mk2 and Mk2.5 apart can be a little trickier. The Mk2 was produced between 1998 and 2000, a relatively short run in the grand scheme of things and the Mk2.5 took the reins until 2005. The key differences are headlights; Mk2.5 headlights use projector lenses and are a slightly more sculpted and a less rounded shape, front grille; as with the headlights the grille opening became a little more sculpted, rear lights; the Mk2's rear light clusters had large orange indicators, whereas on the Mk2.5 Mazda went with clear lenses.

### Mk3, Mk3.5 & Mk3.75 (2005-15)

Mazda made 3 iterations of the Mk3 MX-5, each with their own differences which were mostly aesthetic. The Mk3 ran from 2005 to 2008 and is easily distinguished from the Mk2 with its longer, wider and more rounded appearance, the Mk3.5 which was produced between 2008 and 2013 saw a larger grille opening, leaf shaped fog lamp openings and slightly more angular headlights, at the rear of the car, Mazda removed some of the chrome from the rear light clusters, replacing it with red glass. In 2013 Mazda produced the final run of the Mk3 MX-5 known as the Mk3.75 the most obvious differences were again, an even larger grille opening that the Mk3.5 and squarer fog lamp openings producing a slightly more aggressive front end.

### Mk4 (2015-Present)

2015 saw the introduction of the Mk4 MX-5 with striking new looks. The differences are easily distinguished from the Mk3 and are considerable with smaller proportions and more angular bodywork. The headlights are short and angular, the sharper body lines are immediately obvious and the rear light clusters that start as a round unit are sculpted to a sharper point on the outside of the car, in line with the body work. As March of 2017 came around Mazda released a new model of the Mk4 dubbed the 'RF', with a fixed C pillar and fastback style completely redesigning the look and feel. The RF has run alongside the soft top Mk4 ever since.

## Catalogue Contents

### Engines & Components

Mk1-2.5	Pages 48 & 49
Mk3	Page 50

### Fuel System & Exhausts

Mk1-2.5	Page 51
---------	---------

### Cooling System

Mk1-2.5	Page 52
Mk3	Page 53

### Clutch & Gearbox

Mk1-2.5	Page 54
Mk3	Page 55

### Steering & Suspension

Mk1-2.5	Pages 56 & 57
---------	---------------

### Brakes

Mk1-2.5	Pages 58 & 59
Mk3	Pages 60 & 61

### Interior Fittings

Mk1-2.5	Pages 62 & 63
---------	---------------

### External Body Fittings

Mk1-2.5	Pages 64 & 65
---------	---------------

### Body Panels

Mk1-2.5	Pages 66 & 67
Mk3	Pages 66 & 67

## Torque Specifications

### Mk1-2.5 Engine

Spark Plugs	11-17 lb-ft
Cam Cap Bolts	8.3-10.4 lb-ft
Cylinder Head Bolts	56-60 lb-ft
(must be done in stages and correct order)	
Crank Pulley Main Bolt (SNC)	80-87 lb-ft + threadlock
Crank Pulley Main Bolt (LNC)	116-122 lb-ft + threadlock
Crank Pulley Bolts	9-12 lb-ft (109-151 in-lbs)
Cam Cover Bolts	3.5-6.5 lb-ft (43-78 in-lbs)
(Must be done in correct order)	
Coil Pack Bolts	11.7 lb-ft
Alternator Mounting Bolt	27-38 lb-ft
Alternator Tensioner Bolt	14-19 lb-ft
Timing Belt Tensioner/Idler Bolts	28-38 lb-ft
Timing Belt Cover	5.75-8 lb-ft (69-95 in-lb)
Engine Oil Drain Plug (19mm)	22-30 lb-ft

### Mk3 Engine

Spark Plugs	8-10 lb-ft
Engine Oil Drain Plug	23-30 lb-ft
Engine Oil Change Plate	14-19 lb-ft

### Mk1-2.5 Cooling

Water Pump	14-19 lb-ft
Water Pump Pulley	5.75-8 lb-ft (69-95 in-lb)
Water Inlet Pipe	14-19 lb-ft
Radiator Upper Bolts	14-19 lb-ft
Thermostat Cover	14-19 lb-ft

### Mk1-2.5 Brakes

Front/rear Carrier Bolts	36-51 lb-ft
Banjo bolts	16-22 lb-ft
Rear Adjuster Plug Bolts	9-12 lb-ft
Bleed Nipples	Hand Tight

### Mk3 Brakes

Caliper Guide Pin - front	16-23 lb-ft
Caliper Guide Pin - rear	15-18 lb-ft
Carrier Bolts - front	58-75 lb-ft
Carrier Bolts - rear	36-49 lb-ft
Bleed nipples	Hand tight

### Mk1-2.5 Suspension

Anti-Roll Bar Bush Nuts - front	13-20 lb-ft
Anti-Roll Bar Bush Nuts - rear	14-21 lb-ft
Anti-Roll Bar Drop Link Bolts	27-40 lb-ft
Top Mount to Chassis Nuts	22-27 lb-ft
Damper to Top Mount Nut	23-34 lb-ft
Lower Damper Bolt	54-69 lb-ft
Lower Wishbone Outer Bolt - front	54-69 lb-ft
Ball Joint Upper/Lower Spindle	54-69 lb-ft
Camber Adjustment Bolts - front	69-83 lb-ft
Camber Adjustment Bolts - rear	54-70 lb-ft
Wheel Nuts	66-86 lb-ft

### Mk3 Suspension

Anti-Roll Bar Bracket, front	26-37 lb-ft
Anti-Roll Bar Bracket, rear	13-20 lb-ft
Anti-Roll Bar Drop Link	32-45 lb-ft
Top Mount to Chassis Nuts	34-46 lb-ft
Damper to Top Mount Nut	28-34 lb-ft
Lower Damper Bolt	58-75 lb-ft
Upper Wishbone Bolts - front	62-72 lb-ft
Upper Wishbone Ball Joint	42-53 lb-ft
Upper Wishbone Brake Line Bracket	14-19 lb-ft
Bolts into Boot	17-23 lb-ft
Upper Wishbone Bolts - Rear	56-75 lb-ft
Wheel Nuts	75-80 lb-ft

## How can I modify my MX-5

The MX-5 has been around for decades, and as such, there have been thousands of aftermarket modifications, and not just for the earlier Mk1's, ever since the Mk4's release in 2015, there have been many performance and visual modifications released.

So what is there that you can do to modify your car to your tastes and bring out its maximum potential? Please see below for a brief example of modification that you can do to your car to bring out its maximum potential. For our full range of performance parts, please see our accessory section, or visit our website for up to date stock, prices and new products.

### Suspension

It's a well known fact that the standard MX-5 suspension, especially on the earlier Mk1-2.5 models can be a little tired and sub-par, making what should be an excellent handling car a bit of a boat. There are multiple options available for suspension depending on how you wish to modify it. The cheapest option is a set of lowering springs, which replace your standard MX-5's springs, keeping your factory dampers and top mounts, it is worth noting however, that this is not a remedy for worn out dampers.

The next option is a full suspension kit, this includes a set of springs, either standard height or various lengths for lowering your car, and a full set of dampers. As with a set of lowering springs, this involves taking apart your factory suspension and retaining the original top mounts.

Lastly, and the most performance oriented option, is a full set of adjustable coilovers. This is a complete replacement for your factory suspension including springs, matched dampers, and a lot of decent coilovers also include their own top mounts, making it a relatively simple bolt-on modification. Many performance coilovers are also adjustable, and depending on the type of coilover you decide on, there are multiple adjustments than can be made. For example, the Meister R coilovers that we sell are damping adjustable via a knob that can be turned clockwise or counter clockwise, adjusting the damping to be either softer or harder. The spring is located on its own perch, meaning that preload can be adjusted, without changing the ride height. Lastly, a large portion of the damper body is threaded and locates into a threaded cup at the bottom of the assembly, this allows for ride height to be adjusted independently of any other settings, resulting in a no compromise suspension set up.

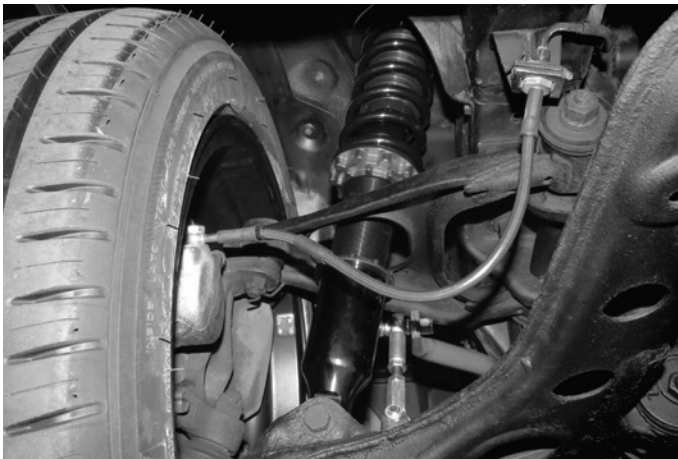

### Anti-Roll Bars

Anti-Roll bars, or sway bars as they are sometimes called, are an often overlooked, but essential part of any performance set-up for your MX-5. The job of an anti-roll bar is to stabilise the car as it's turning, reducing the body roll and keeping the car as flat as possible through a corner, resulting in a more stable and easier to control experience. Sizing of anti-roll bars are hugely important, and can drastically alter the way the car handles. Too thick on the front and you will introduce understeer and too thick on the rear can result in oversteer, meaning that a performance set of anti-roll bars needs to be balanced perfectly between front and rear. Moss Europe supplies performance anti-roll bars, and adjustable drop links to help bring out the full potential of your performance anti-roll bar.

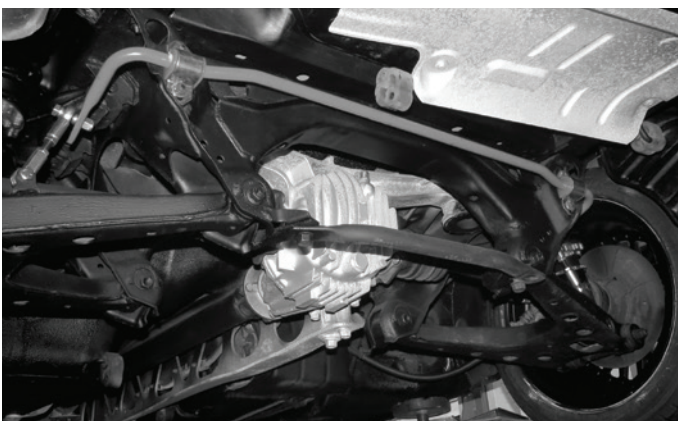

### Brakes

Brakes are a fairly simple concept, by converting the kinetic energy of the car moving forward, to heat energy in the brake discs you begin to slow down. As such, the more heat that the brakes can dissipate, the more efficient your brakes will be. Alternatively, when space is limited, considerably better pads and discs can also make the world of difference in not just heat dissipation, but how much heat they can take. Moss Europe supplies a multitude of aftermarket and performance brake discs and pads for all MX-5's, and for those with a Mk1-2.5, we can also supply Wilwood 4 pot big brake kits, increasing not only size and thermal capacity, but also serviceability by being a bell and rotor construction as opposed to a single piece disc.

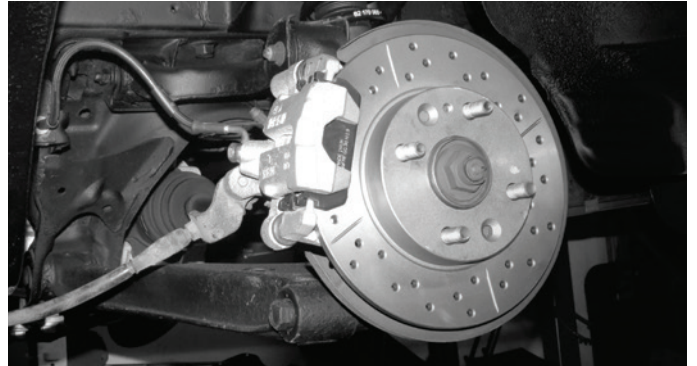

### Intake

A very quick and simple modification that can be performed by even the most amateur mechanics with very basic skills, tools and knowledge and work on the premise of allowing the inlet side of your engine to breathe better, this can be done in a couple of ways. The simplest and most standard looking is a high flow air filter, which sits in your factory airbox, replacing your standard and restrictive air filter. The second is an induction kit, which replaces your factory airbox completely. There is a down side to induction kits, and that's the fact that they usually get placed right above the exhaust manifold, and are unshielded, resulting in drawing in hotter air, reducing air density, and, as a byproduct, less power. A well designed induction kit, such as our Cobalt induction kit for the Mk2-2.5 includes a shield to keep it as closed off from the heat as possible. Regardless of whether an induction kit improves or reduces power, they really add to the 'fun' factor of driving and MX-5 by releasing a more throaty induction noise from your engine. Moss Europe offer a number of different induction kits for your MX-5, regardless of model.



### Silicone Hoses

Mazda use kevlar weaved rubber hoses from the factory, and whilst they do their job, they tend to deteriorate over time and can burst, so instead of replacing them, why not upgrade them at the same time with silicone hose sets. Silicone is more resilient to temperature, oil and petrol, and can take a greater pressure before rupturing, making them an excellent upgrade from the factory kevlar weaved rubber.



**Coolant Reroute Kits**

Mk1-2.5 MX-5's get a hot spot around cylinder 4 as coolant flow starts to stagnate due to the coolant route from the factory. Generally this isn't an issue for people driving on the road, however, if you're pushing your car harder on the road, or driving hard on the track, you can start running into cooling issues. Luckily, there's a simple fix in the way of a coolant reroute. The idea behind a coolant reroute is that, instead of the radiator top hose and thermostat at the front of the engine, it is moved to the rear, resulting in a more even coolant flow, a much more efficient cooling system and the ability to run the engine harder for longer.



**Radiator**

Radiators are a fairly simple idea. Hot water flows through the core, the heat is transferred to the fins and the air flowing through the radiator then removes that heat from the fins, this is why your fan comes on sitting in traffic, if there's no air movement, there's no cooling potential. So what makes an aftermarket radiator more efficient? The first point is depth, not only does a larger radiator increase the surface area for more cooling fins, but also more mass meaning more material to remove the heat from the water. The second reason is construction. Most aftermarket aluminium radiators feature full aluminium construction, meaning greater thermal transfer and greater reliability, it's a well known fact that OE MX-5 radiators with their plastic tops and bottoms tend to spontaneously fail after time. Moss Europe can supply you quality aftermarket items for all models of MX-5.

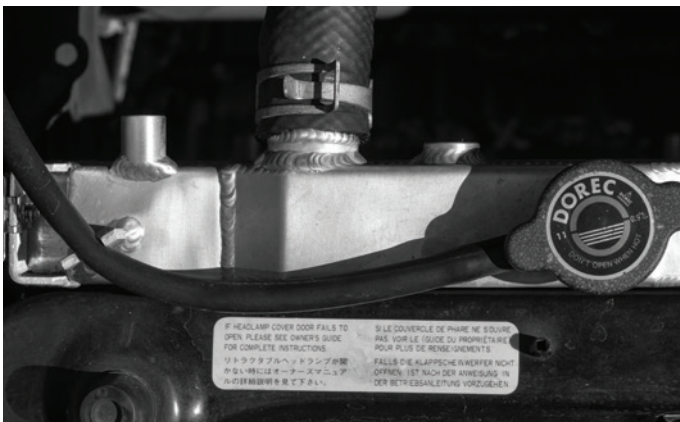

**Radiator Slam Panels**

Simple, yet effective. Radiator slam panels are panels that bolt over the top of your radiator and help to ensure that any air coming into the engine bay from the front of the car goes through the radiator, paired with the undertray and air guide, you can ensure that maximum cooling efficiency is achieved. A simple bolt-on modification that can have a very real and measurable effect.

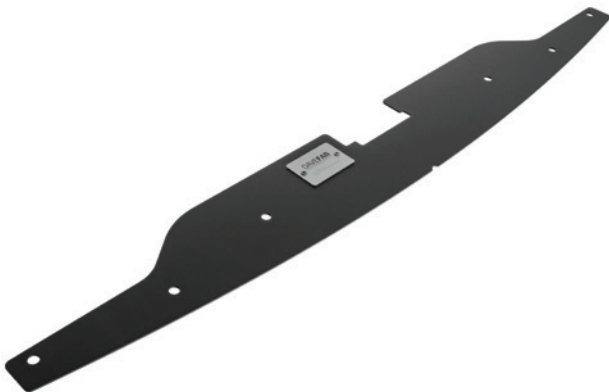

**Exhaust**

Perhaps the most common modification MX-5 owners do is change their exhaust system. Not only does it improve flow with a larger bore and higher flowing mufflers, helping release a couple of horsepower, but also makes a much better noise than the factory exhaust system, giving you a much more fun driving experience. The general rule of thumb for changing the MX-5's exhaust is to start from the back of the car with the backbox and centre pipe, then work forward from there as it is generally the rear section of the exhaust that is most restrictive, whilst also being the simplest part to change. Our range of Cobalt exhaust systems for your car, are beautifully made in high quality stainless steel, and come with a 5 year warranty against defects in materials and workmanship. We can supply a Cobalt exhaust for your MX-5, no matter the model.

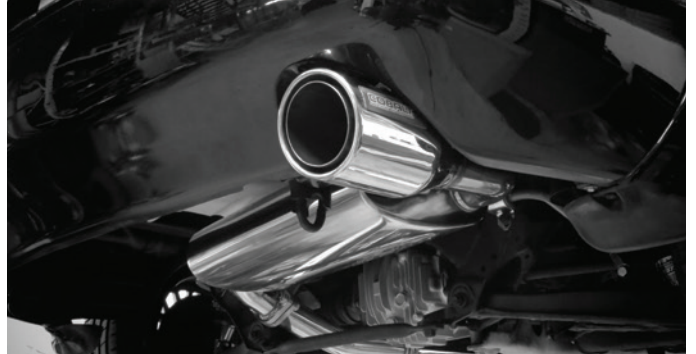

**Clutch**

The clutch transmits power from the engine through to the transmission and can be an essential modification when increasing power output, some owners also change the clutch to a performance part if the car is regularly being driven hard on the road or at track days. Moss Europe supply performance clutch kits from Competition Clutch, giving you the confidence to push your MX-5 to the limit time and time again.



**Flywheels**

Factory flywheels are heavy, that's because Mazda needed to ensure that the MX-5 was as drivable as possible. By reducing this mass, the engine can rev faster and more freely, resulting in improved throttle response, and an ultimately better driving experience. Moss Europe supply a range of flywheels, each with different mass, allowing you to pick the flywheel that's suitable for you.



### Short Shifter Kits

The MX-5 is well renowned for having an excellent gearbox with great feel and precise changes, however, the throw (distance between gears on the shifter) has a tendency to be a little too far. Luckily, there's a simple fix in the way of a short shift kit. These work by changing the pivot and fulcrum in the shifter, resulting in a shorter throw and a tighter feel. Our Cobalt short shift kits do exactly that, giving your MX-5 a brand new and engaging feel, especially when matched with our bronze gear lever bushes and a brand new set of gaiters.



### Wheels & Tyres

Unsprung weight is the mass of the car that is not supported by the suspension such as, wheels and tyres, brakes and axle assemblies. Reducing this unsprung weight allows the suspension to keep the wheels and tyres in contact with the road more efficiently, improving grip and handling. One of the simplest way to achieve this is with lightweight wheels such as the Enkei RPF1's or large selection of Japan Racing Wheels that Moss Europe can supply in perfect specifications for fast road or the race track.



### Lighting

Headlights may not be an obvious part of your MX-5 to upgrade, but decent bulbs, or even complete replacement units if you own a Mk1. Whilst they may not be performance oriented, being able to see when it's dark is essential for driving at night and giving you the confidence to be drive safely and distinguish hazards earlier. Additionally, LED bulbs can make a huge difference, LED's turn on and off immediately, and are generally brighter than incandescent bulbs, an essential in a car as small as an MX-5.

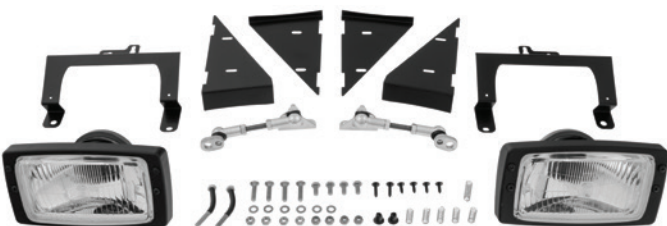

### Driving Courses & Track Days

Whilst not exactly a modification, the only way to unleash any cars true potential is on a closed circuit. Not only do track days allow you to find the limits of your car, but also your driving technique and skill. Some trackdays even offer tuition from qualified instructors, perfect if it's your first time or are looking to push your skills further. Advanced driving courses offer a different, but just as important experience. Covering more road based driving essentials such as; control, observation, road positioning, other road users, and more. Such courses not only help you become a more aware, safer driver on the road, but can contribute to cheaper car insurance and a boost in confidence when out on the roads. No matter what, improving your skills and understanding your cars limits and abilities will make you a safer driver on the road, and a faster driver on the track.



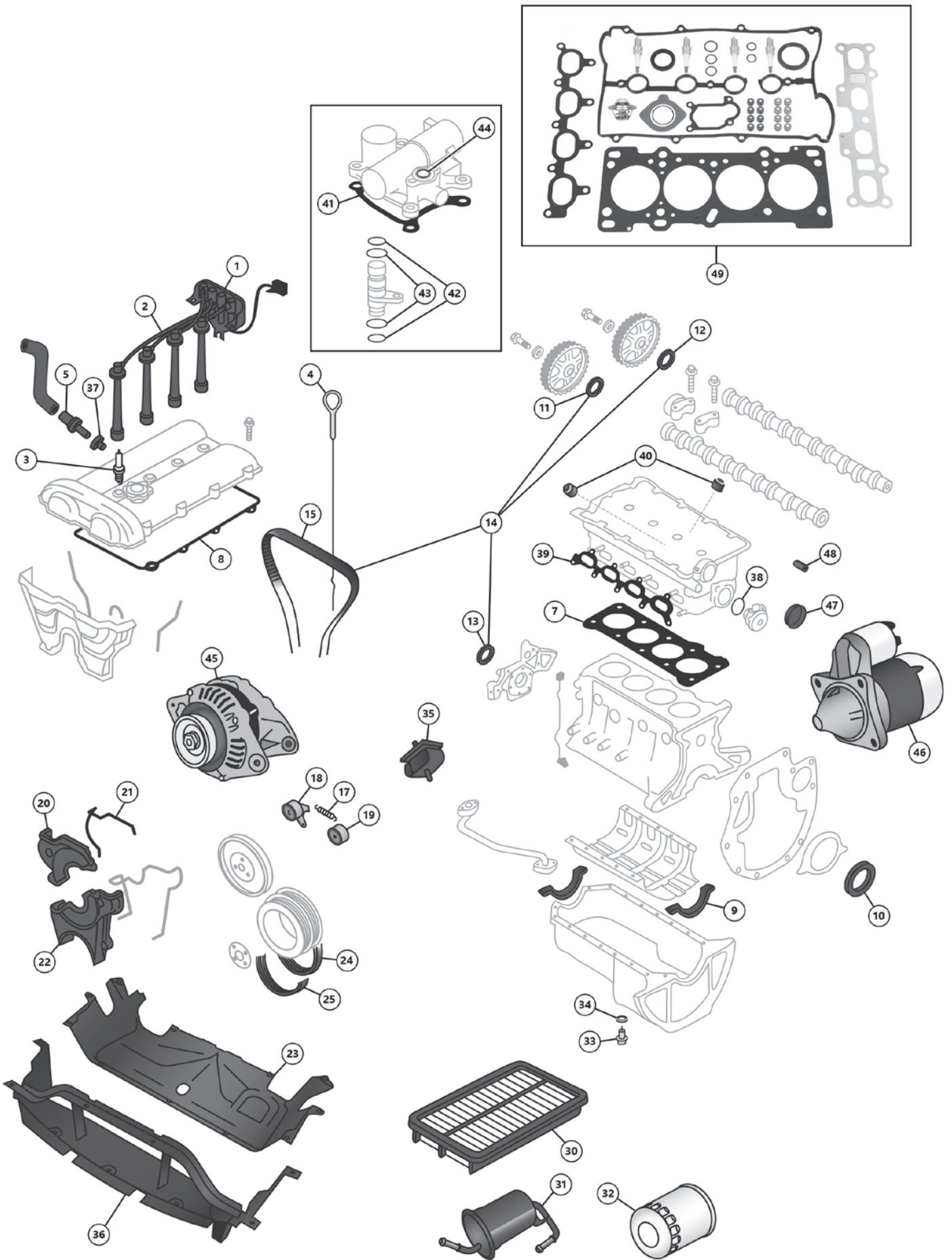



ill.	Part Number	Price £ea.	Description	Req.	Details
<b>Internal &amp; External Engine - Mk1-2.5</b>					
1	902-858	£320.00	COIL & IGNITOR, OEM	1	1989-89 1.6
	909-790	£135.00	COIL & IGNITOR	1	1989-89 1.6
	902-863	£370.00	COIL & IGNITOR, OEM	1	1994-95 1.8 up to VIN 619600
	902-860	£405.00	COIL & IGNITOR, OEM	1	1998-05 non-VVT
	910-390	£125.00	COIL & IGNITOR	1	1998-05 non-VVT
	909-792	£45.00	COIL PACK	2	2001-05 VVT
2	971-510	£26.60	HT LEAD, red, set of 4, JR	1	1989-05 non-VVT
	971-108	£29.60	HT LEAD, blue, set of 4, Cobalt	1	1989-05 non-VVT
	971-109	£14.80	HT LEAD, blue, pair, Cobalt	1	2001-05 VVT
3	BKR6E-11	£3.30	SPARK PLUG, OEM	4	1989-05 1.6
	BKR5E-11	£3.40	SPARK PLUG, OEM	4	1994-05 1.8
4	904-951	£25.00	DIP STICK, oil, OEM	1	1994-97 1.8
	904-952	£29.90	DIP STICK, oil, OEM	1	1998-05
	905-235	£12.00	DIP STICK, oil	1	1989-97 1.6
5	MXV2002	£14.00	PCV VALVE, OEM	1	1989-97 & 2001-05 1.6/1.8
	MXV2002Z	£11.60	PCV VALVE, aftermarket	1	1989-97 & 2001-05 1.6/1.8
	971-091	£25.00	PCV VALVE, OEM	1	1998-00
	971-092	£6.00	PCV VALVE	1	1998-00
7	901-910	£58.00	HEAD GASKET, OEM	1	1989-05 1.6
	901-915	£80.00	HEAD GASKET, OEM	1	1994-00 1.8 non-VVT
	901-917	£85.00	HEAD GASKET, OEM	1	2001-05 1.8 VVT
8	971-031	£28.80	GASKET, cam cover, OEM	1	1989-05 1.6
	971-034	£52.00	GASKET, cam cover, OEM	1	1994-00 1.8 non-VVT
	971-036	£42.00	GASKET, cam cover, OEM	1	2001-05 1.8 VVT
	MXV8109	£27.80	GASKET, cam cover	1	1989-05 1.6
	MXV8108	£18.10	GASKET, cam cover	1	1994-00 1.8 non-VVT
9	907-125	£39.00	SUMP SEAL, set, OEM	1	1989-00
	907-207	£6.00	SUMP SEAL, set	1	1989-00
10	902-375	£32.40	SEAL, crankshaft, rear, OEM	1	1989-05
	902-376	£6.20	SEAL, crankshaft, rear	1	1989-05
11	971-020	£7.50	SEAL, camshaft, front	2	1989-05 1.6 & 1.8 non-VVT
12	971-021	£7.50	SEAL, camshaft, front	1	2001-05 1.8 VVT
13	971-025	£6.90	SEAL, crankshaft, front	1	1989-91 short nose crank
	971-040	£6.50	SEAL, crankshaft, front	1	1991-05 long nose crank
14	MXV1132X	NCA	TIMING BELT & SEALS, Gates	1	1989-91 1.6
	MXV8103	£63.30	TIMING BELT & SEALS, Gates	1	1991-05
15	MXV8104	£22.30	TIMING BELT, Gates	1	1989-05
17	904-902	£5.70	SPRING, tensioner, OEM	1	1989-05
18	MXV8106	£27.60	TENSIONER PULLEY, timing belt	1	1989-05
19	MXV8107	£18.00	IDLER PULLEY, timing belt	1	1989-05
20	902-850	£46.00	TIMING COVER, middle, OEM	1	1989-05
21	902-851	£18.00	GASKET, timing cover, mid, OEM	1	1989-05
22	902-852	£45.00	TIMING COVER, lower, OEM	1	1989-05
23	902-853	£76.40	UNDERTRAY, engine, OEM	1	1989-05
24	901-890	NCA	BELT, alternator, OEM	1	1989-97 Mk1 1.6
	901-891	£16.00	BELT, alternator, Gates	1	1989-97 Mk1 1.6
	901-885	£19.00	BELT, alternator, OEM	1	1994-05 Mk1 1.8/ Mk2 1.6/1.8
25	901-815	£57.70	BELT, PS & AC, OEM	1	1989-05
	901-816	£7.60	BELT, PS & AC	1	1989-05
30	971-100	£19.00	AIR FILTER, OEM	1	1989-97
	MXV8114	£5.40	AIR FILTER	1	1989-97
	MXV8115	£6.30	AIR FILTER	1	1998-05
31	MXV8117	£12.70	FUEL FILTER	1	1989-97
	971-081	£29.00	FUEL FILTER, OEM	1	1998-05
	971-082	£7.20	FUEL FILTER	1	1998-05
32	900-950	£8.10	OIL FILTER, OEM	1	1989-05
	MXV8113	£5.80	OIL FILTER	1	1989-05
33	MXV1195X	£6.10	PLUG, oil drain, magnetic	1	1989-05
34	902-192	£0.73	GASKET, drain plug, magnetic	1	1989-05
	901-968	£2.10	GASKET, drain plug, x10, OEM	1	1989-97
	901-969	£0.90	GASKET, drain plug, single, OEM	1	1998-05
35	904-900	£55.20	ENGINE MOUNT, OEM	2	1989-97
	903-971	£45.60	ENGINE MOUNT, MazdaSpeed	2	1998-05
	902-620	£40.30	ENGINE MOUNT	2	1989-97
36	907-191	£90.00	AIR GUIDE, OEM	1	1989-97 non-ABS models
37	904-839	NCA	GASKET, PCV valve, OEM	1	1989-05
38	902-884	£8.00	O-RING, cam angle sensor, OEM	1	1989-97
39	903-990	£54.70	GASKET, inlet manifold, Hondata	1	1989-93
	903-991	£55.00	GASKET, inlet manifold, Hondata	1	1994-97
	903-992	£54.40	GASKET, inlet manifold, Hondata	1	1998-05
40	971-193	£10.00	SEAL, valve stem, inl/ex, OEM	16	1989-93
	971-192	£12.00	SEAL, valve stem, inlet, OEM	8	1994-05
	971-193	£10.00	SEAL, valve stem, exhaust, OEM	8	1994-05
41	901-955	£5.00	GASKET, VVT housing, OEM	1	2001-05
42	901-956	£5.00	O-RING, VVT internal, small, OEM	2	2001-05
43	901-957	£5.00	O-RING, VVT internal, large, OEM	2	2001-05
44	901-958	£5.00	O-RING, VVT oil supply, OEM	1	2001-05
45	901-730	£173.70	ALTERNATOR	1	1989-93
	901-731	£148.80	ALTERNATOR	1	1994-97
	901-732	£219.30	ALTERNATOR	1	1998-00

ill.	Part Number	Price £ea.	Description	Req.	Details
	901-733	£176.50	ALTERNATOR	1	2001-05
46	901-734	£170.50	STARTER MOTOR	1	1989-97
	901-735	£115.20	STARTER MOTOR	1	1998-05
47	971-029	£12.00	PLUG, cam angle sensor, OEM	1	1998-05
48	971-196	£7.50	CAP, sealing, water outlet, OEM	1	1989-93
49	902-535UK	£326.35	REBUILD KIT, cylinder head, OEM	1	1989-97 1.6
	902-536	£363.30	REBUILD KIT, cylinder head, OEM	1	1994-97 1.8
	902-537	£355.60	REBUILD KIT, cylinder head, OEM	1	1998-00 1.6/1.8
	902-538	£365.40	REBUILD KIT, cylinder head, OEM	1	2001-05 1.8 VVT

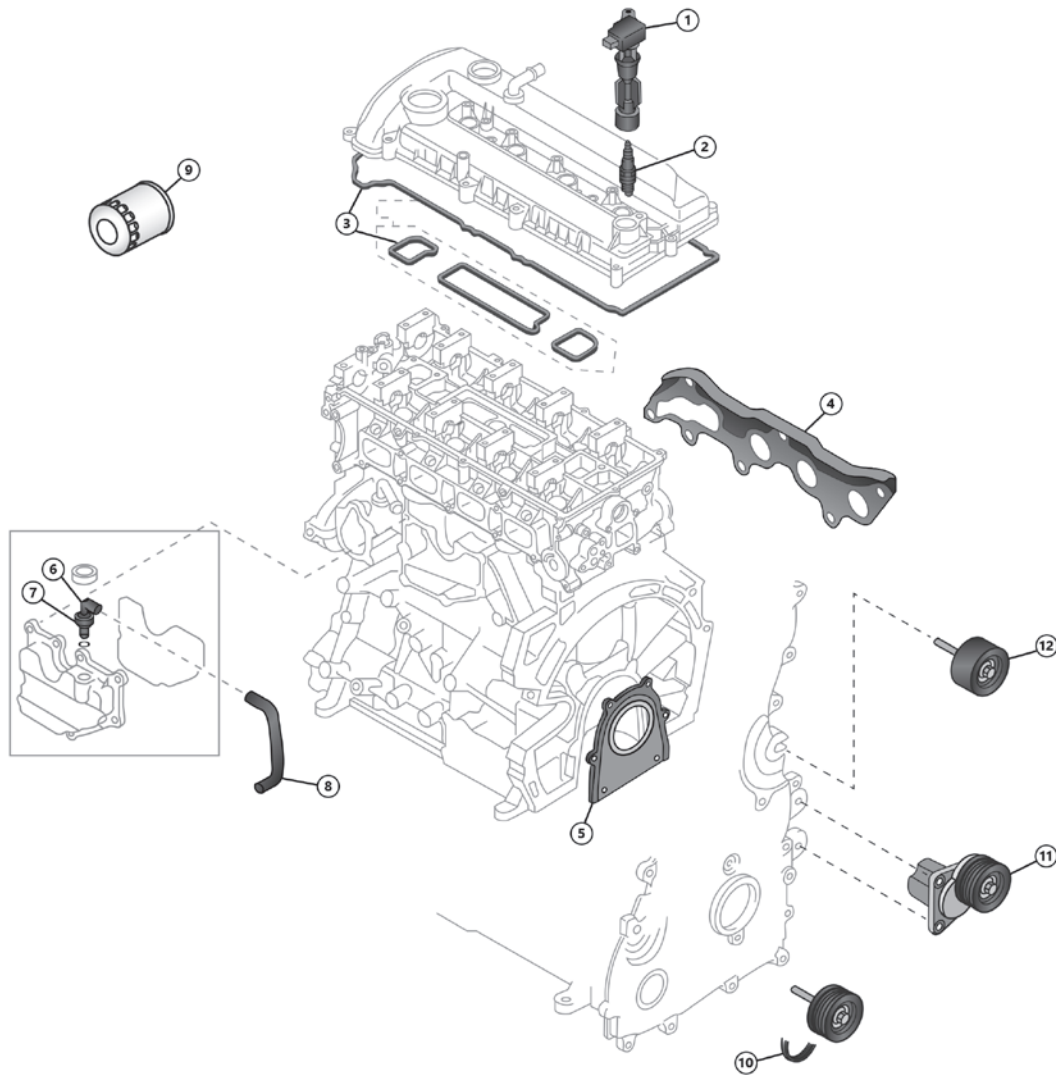
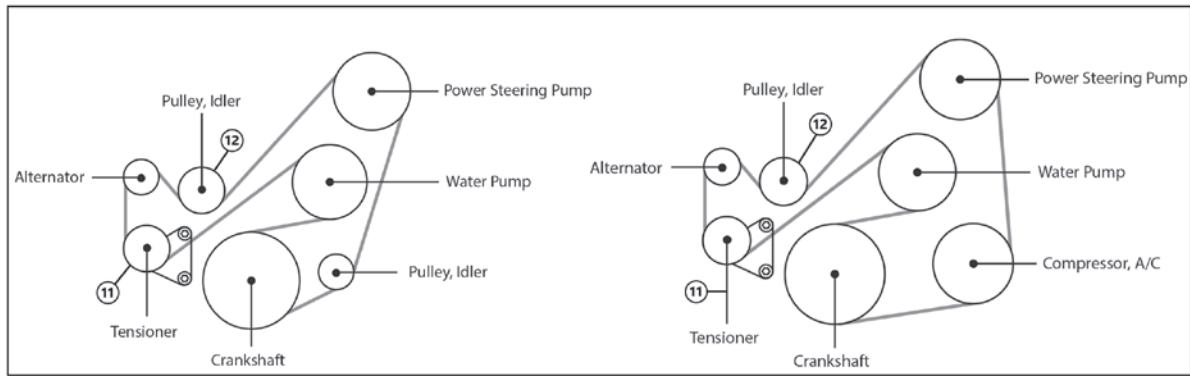

ill.	Part Number	Price £ea.	Description	Req.	Details
<b>Internal &amp; External Engine - Mk3</b>					
1	903-480	£112.00	COIL, OEM	4	2006-15
	903-481	£68.00	COIL	4	2006-15
2	903-495	£21.00	SPARK PLUG, OEM	4	2006-15
3	903-485	£28.80	GASKET, valve cover, OEM	1	2006-15
	903-486	£16.60	GASKET, valve cover	1	2006-15
4	903-490	£30.10	GASKET, exhaust manifold, OEM	1	2006-15
	903-491	£18.90	GASKET, exhaust manifold	1	2006-15
5	903-465	£88.00	SEAL, crankshaft, rear, OEM	1	2006-15
	903-466	£47.00	SEAL, crankshaft, rear	1	2006-15
6	903-525	£15.00	VALVE, PCV, OEM	1	2006-15
7	903-527	£6.00	SEAL, PCV valve, OEM	1	2006-15
8	903-526	£16.00	HOSE, PCV valve, OEM	1	2006-15
9	902-856	£10.20	OIL FILTER, OEM	1	2006-15
10	910-900	£58.00	BELT, serpentine, OEM	1	2006-08 With AC
	910-915	£30.00	BELT, serpentine	1	2006-08 With AC
	910-901	£161.40	BELT, serpentine, OEM	1	2006-08 Without AC
	910-916	£34.00	BELT, serpentine	1	2006-08 Without AC
	910-902	£53.00	BELT, serpentine, OEM	1	2009-15 With AC
	910-917	£18.00	BELT, serpentine	1	2009-15 With AC

ill.	Part Number	Price £ea.	Description	Req.	Details
10	910-917	£18.00	BELT, serpentine	1	2009-15 With AC
	910-903	£56.00	BELT, serpentine, OEM	1	2009-15 Without AC
	910-918	£30.00	BELT, serpentine	1	2009-15 Without AC
11	910-905	£149.00	TENSIONER, belt, OEM	1	2006-15 } manual transmission
	910-920	£36.00	TENSIONER, belt	1	2006-15 } automatic transmission
	910-907	£208.00	TENSIONER, belt, OEM	1	2006-15 } automatic transmission
12	910-910	£62.00	IDLER PULLEY, upper, OEM	1	2006-15 } with AC
	910-925	£42.00	IDLER PULLEY, upper	1	2006-15 } with AC
	910-911	£99.00	IDLER PULLEY, lower, OEM	1	2006-15 } without AC
	910-926	£25.00	IDLER PULLEY, lower	1	2006-15 } without AC

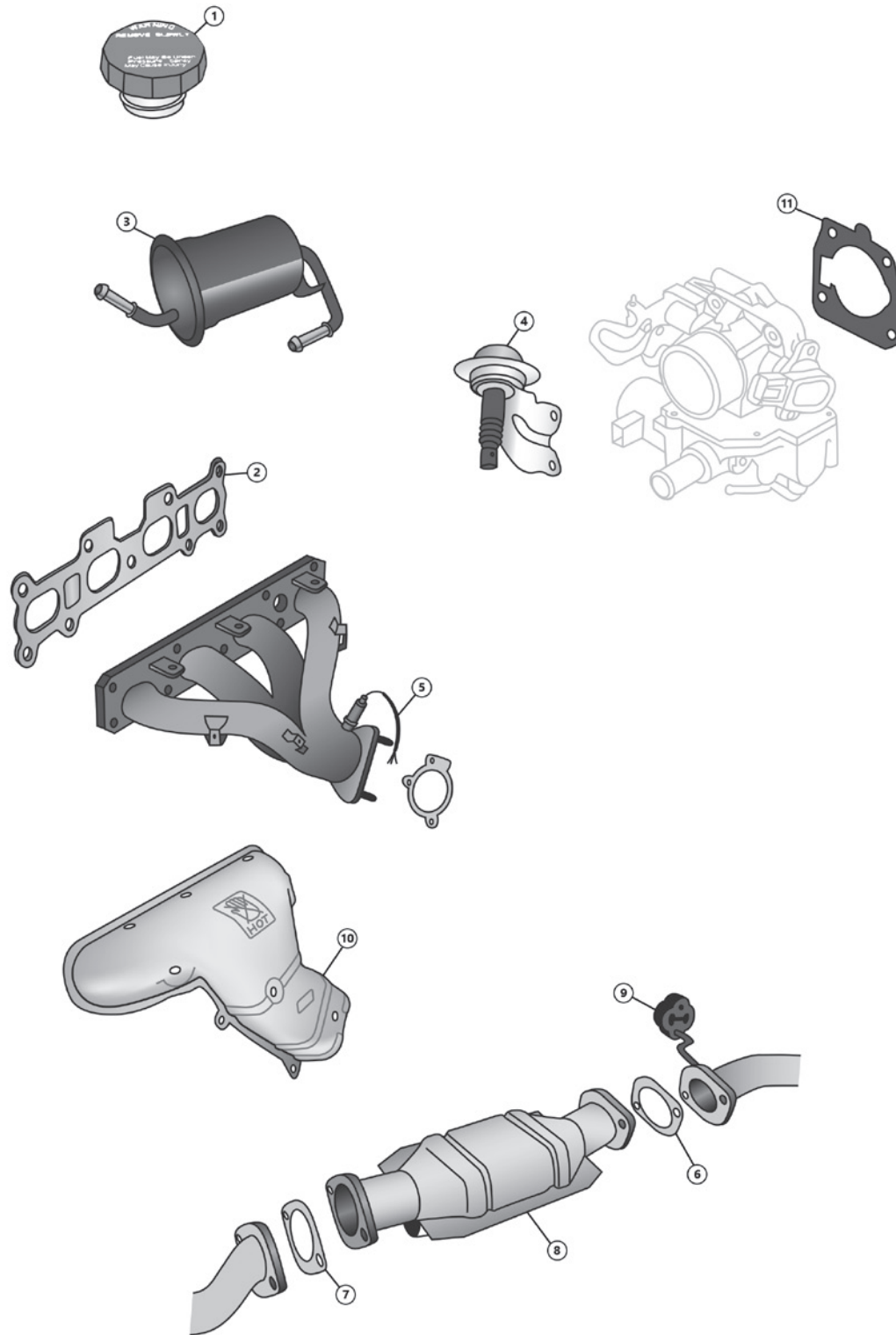

ill.	Part Number	Price £ea.	Description	Req.	Details
<b>Fuel System &amp; Exhaust - Mk1-2.5</b>					
1	901-895	£39.30	FUEL CAP, OEM	1	1989-95
	901-900	£23.00	FUEL CAP, OEM	1	1996-97
	901-901	£27.00	FUEL CAP, OEM	1	1998-05
2	MXV1061X	£21.70	GASKET, manifold, ex. OEM	1	1989-05 1.6
	MXV1066X	£18.40	GASKET, manifold, ex. OEM	1	1994-97 1.8
	901-881	£18.00	GASKET, manifold, ex. OEM	1	1998-05 1.8
3	MXV8116	£10.80	FILTER, fuel	1	1989-97
	971-081	£29.00	FILTER, fuel, OEM	1	1998-05
	MXV8117	£12.70	FILTER, fuel	1	1998-05
4	971-300	£115.00	DASHPOT, OEM	1	1989-97 1.6
5	902-650	£40.70	O2 SENSOR, 1-wire	1	1989-94
	902-651	£78.30	O2 SENSOR, 4-wire	1	1994-05
6	052-342	£5.60	GASKET, exhaust, front	1	1989-97
	051-633	£13.70	GASKET, exhaust, front, OEM	1	1998-05 manual transmission
7	052-342	£5.60	GASKET, exhaust, rear	1	1989-97
	051-633	£13.70	GASKET, exhaust, rear, OEM	1	1998-05
	052-470	£6.00	GASKET, exhaust, Cobalt	1	1998-05 fits 900-566 & 909-680
8	NCA		CATALYTIC CONVERTOR	1	1989-93 1.6 370mm

ill.	Part Number	Price £ea.	Description	Req.	Details
	NCA		CATALYTIC CONVERTOR	1	1994-97 1.6/1.8 440mm
	NCA		CATALYTIC CONVERTOR	1	1997-98 1.6/1.8 475mm
	NCA		CATALYTIC CONVERTOR	1	1998-00
9	901-905	£3.20	HANGER, exhaust, OEM	4	1989-97
	902-540	£10.00	HANGER, exhaust, 10mm	4	1989-05 polyurethane
	902-541	£10.00	HANGER, exhaust, 12mm	4	2006-17 polyurethane
10	904-369	£100.00	HEAT SHIELD, ex. manifold, OEM	1	1994-97 1.8
11	908-080	£5.90	GASKET, throttle body, OEM	1	1989-97 1.6
NI	901-304	£210.50	EXHAUST SYSTEM, Cobalt	1	1989-97 single exit
NI	900-482	£255.50	EXHAUST SYSTEM, Cobalt	1	1989-97 dual exit
NI	WPE1104X	£4.50	PLUG, blanking	1	1989-97 fits 900-494 & 900-492
NI	900-566	£190.00	SILENCER, rear, Cobalt	1	1998-05 single exit
NI	909-680	£285.00	SILENCER, rear, Cobalt	1	1998-05 dual exit

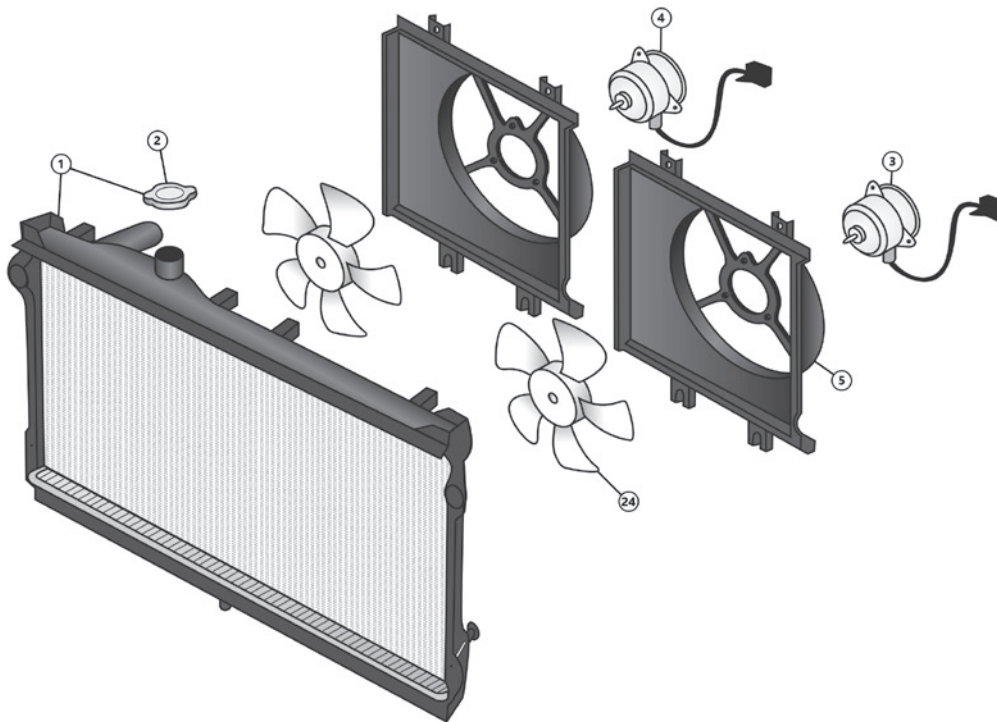
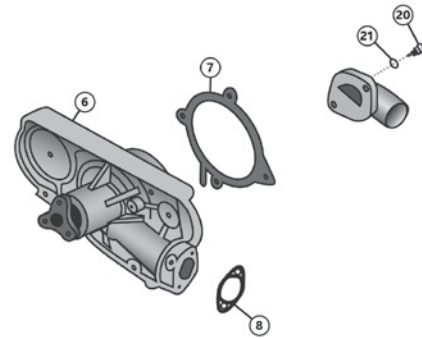
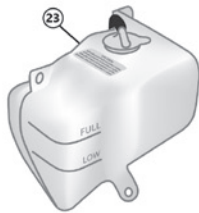
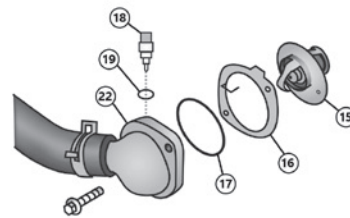
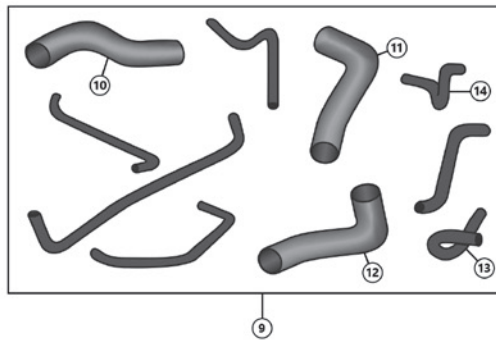

ill.	Part Number	Price £ea.	Description	Req.	Details
<b>Cooling System - Mk1-2.5</b>					
1	904-795	£360.00	RADIATOR, OEM	1	1989-97
	909-880	£95.00	RADIATOR	1	1989-97
	908-140	£169.00	RADIATOR, aluminium, Cobalt	1	1989-97
	908-141	£179.00	RADIATOR, aluminium, Cobalt	1	1998-05
2	902-350	N/A	CAP, radiator, OEM	1	1989-97
	902-352	£8.00	CAP, radiator	1	1989-97
	902-353	£7.90	CAP, radiator	1	1998-05
3	904-181	£225.00	FAN MOTOR, OEM	1	1998-05
4	904-182	N/A	FAN MOTOR, A/C, OEM	1	2001-05
5	904-960	£85.00	SHROUD, cooling fan, OEM	1	1989-97
6	MXV8118	£35.00	WATER PUMP	1	1989-97 1.6
	902-420	£143.00	WATER PUMP, OEM	1	1994-97 1.8 & 1998-05 1.6/1.8
	902-422	£46.00	WATER PUMP	1	1994-97 1.8 & 1998-05 1.6/1.8
7	902-415	£12.70	GASKET, water pump, OEM	1	1989-05
8	902-416	£8.70	GASKET, water pump outlet, OEM	1	1989-05
9	904-904	£129.10	HOSE SET, OEM	1	1989-97 1.6
	904-905	£141.10	HOSE SET, OEM	1	1994-97 1.8
	904-906	£158.90	HOSE SET, OEM	1	1998-00
	MXV1060	£80.00	HOSE SET, silicone	1	1989-97 1.6
	MXV1061	£80.00	HOSE SET, silicone	1	1994-97 1.8

ill.	Part Number	Price £ea.	Description	Req.	Details
9	MX5160B	£80.00	HOSE SET, silicone	1	1998-05, 1.6
	MX51061	£91.00	HOSE SET, silicone	1	1998-05, 1.8
	MX51061	£91.00	HOSE SET, silicone	1	1998-05, 1.8
10	902-370	£21.90	HOSE, radiator, top, OEM	1	1994-97
11	902-355	N/A	HOSE, pipe to pump, OEM	1	1989-97
12	902-360	£16.30	HOSE, radiator, lower, OEM	1	1989-97
13	903-532	£18.00	HOSE, heater, inlet, OEM	1	1989-97
	903-237	£20.00	HOSE, heater, inlet, OEM	1	1998-05
14	903-530	£20.00	HOSE, heater, outlet, OEM	1	1989-97 1.6
	903-531	£20.00	HOSE, heater, outlet, OEM	1	1994-97 1.8
	903-238	£20.00	HOSE, heater, outlet, OEM	1	1998-05
15	MXV8121	£8.30	THERMOSTAT, 82°	1	1989-97 1.6
	MXV8120	£9.20	THERMOSTAT, 89°	1	1994-97 1.8
	999-032	£5.00	THERMOSTAT, 88°	1	1998-05
16	999-023	£2.70	GASKET, thermostat	1	1989-05
17	903-037	£5.00	O-RING, thermostat housing, OEM	1	1989-05
18	902-870	£7.60	SENSOR, fan switch	1	1989-97 1.6
19	902-879	£8.00	O-RING, fan switch, OEM	1	1989-97 1.6
20	902-871	£9.60	SENSOR, coolant temp	1	1989-97
20	903-874	£38.00	SENSOR, coolant temp, OEM	1	1998-05
21	903-873	£2.00	O-Ring, temp sensor, OEM	1	1998-05
22	903-035	£26.00	COVER, thermostat, OEM	1	1989-97
	903-036	£31.30	COVER, thermostat, OEM	1	1994-05
23	904-797	£58.00	EXPANSION TANK, coolant, OEM	1	1989-97
24	904-783	£56.00	FAN, cooling, OEM	2	1998-05

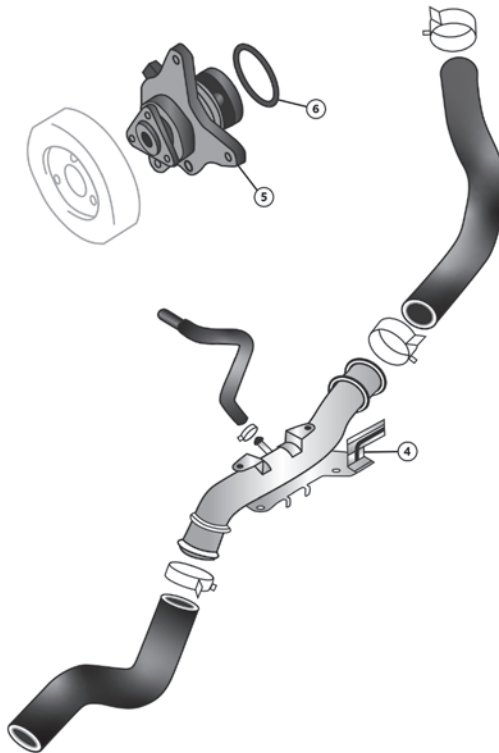
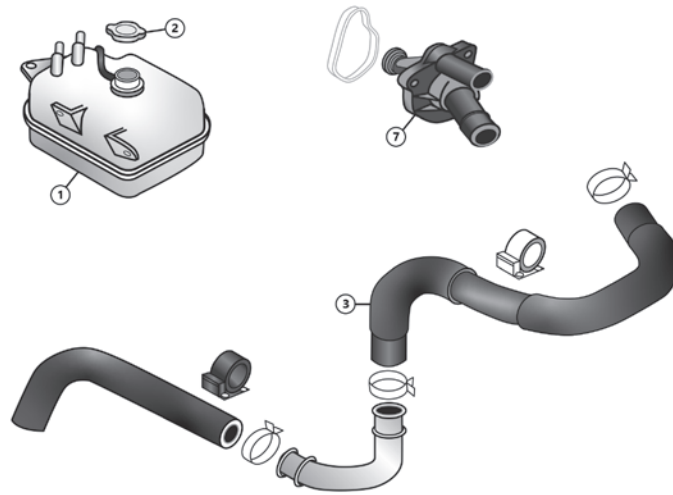

ill. Part Number Price £ea. Description Req. Details

### Cooling System - Mk3

1	971-260	£71.00	EXPANSION TANK, coolant, OEM	1	2006-15
2	971-261	£18.00	CAP, expansion tank, OEM	1	2006-15
3	971-262	£85.00	HOSE, radiator, upper, OEM	1	2006-15
4	971-263	£85.00	HOSE, radiator, lower, OEM	1	2006-08
	971-264	£76.00	HOSE, radiator, lower, OEM	1	2008-09
	971-265	£76.00	HOSE, radiator, lower, OEM	1	2009-15
5	903-470	£76.30	WATER PUMP	1	2006-15
6	903-471	£6.00	GASKET, water pump, OEM	1	2006-15
7	053-141	£24.00	THERMOSTAT, long housing	1	2006-12

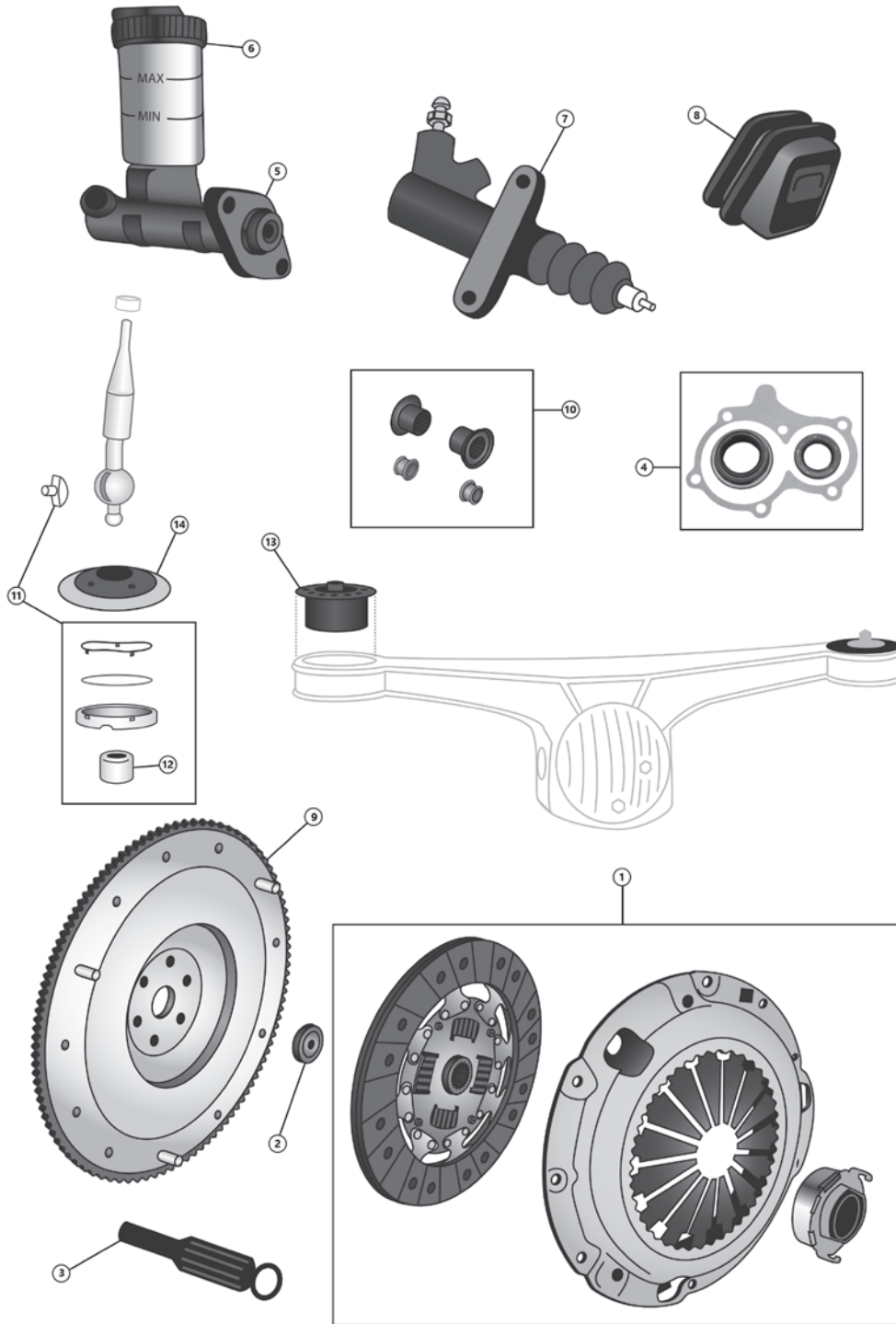

ill.	Part Number	Price £ea.	Description	Req.	Details
<b>Clutch &amp; Gearbox - Mk1-2.5</b>					
1	901-895	£39.30	FUEL CAP, OEM	1	1989-95
	901-900	£23.00	FUEL CAP, OEM	1	1996-97
	901-901	£27.00	FUEL CAP, OEM	1	1998-05
1	MM900-135	£95.60	CLUTCH KIT, 3 piece, Exedy	1	1989-05 1.6
	MM900-136	£122.50	CLUTCH KIT, 3 piece, Exedy	1	1994-05 1.8
2	901-860	£6.50	SPIGOT BEARING, OEM	1	1989-05
3	387-205	£7.90	CLUTCH ALIGNMENT TOOL	1	1989-05
4	902-593	£32.00	SEAL KIT, clutch, OEM	1	1989-05
	902-590	£4.00	GASKET, clutch cover, OEM	1	1989-05
	902-591	£6.00	SEAL, gearbox, front, OEM	1	1989-05
	902-592	£22.00	SEAL, gearbox, rear, OEM	1	1989-05
5			NCA	1	1989-05
	902-300	£160.50	MASTER CYLINDER, LHD, OEM	1	1989-05
	902-630	£44.50	MASTER CYLINDER, LHD	1	1989-05
6	902-301	£14.00	CAP, clutch master, OEM	1	1989-05
7	903-150	£26.60	SLAVE CYLINDER	1	1989-90
					Up to VIN 111969
	903-155	£7.60	SLAVE CYLINDER	1	1990-05
8	902-865	£29.00	GAITER, clutch fork, OEM	1	1989-93
	902-866	£15.40	GAITER, clutch fork, OEM	1	1994-05
9	902-380	£116.40	Ring Gear, flywheel, OEM	1	1989-05

ill.	Part Number	Price £ea.	Description	Req.	Details
10	907-180	£13.00	BUSH, gear lever, OEM	1	1989-97
	907-186	£30.00	BUSH KIT, OEM	1	1989-05
11	907-181	£42.92	BUSH KIT, gear lever, OEM	1	1989-97
	907-220	£20.00	BUSH KIT, gear lever	1	1989-97
	909-933	£39.00	BUSH KIT, gear lever, OEM	1	1998-05
					5 speed
	907-222	£24.00	BUSH KIT, gear lever	1	1998-05
					5 speed
	907-182	£39.50	BUSH KIT, gear lever, OEM	1	2001-05
					6 speed
	907-221	£22.00	BUSH KIT, gear lever	1	2001-05
					6 speed
	907-183	£8.10	BUSH, gear lever, lower, OEM	1	1989-05
12	910-940	£18.30	BUSH, gear lever, lower, bronze	1	1989-97
					5X Racing, 5 speed
	910-942	£19.50	BUSH, gear lever, lower, bronze	1	1998-05
					5X Racing, 5 speed
	910-942	£19.50	BUSH, gear lever, lower, bronze	1	1998-01
					5X Racing, 6 speed
	910-941	£26.10	BUSH, gear lever, lower, bronze	1	2001-05
					5X Racing, 6 speed
13	903-972	£74.70	MOUNT, differential, OEM	2	1989-05
14	770-823	£18.20	BOOT, gear lever, lower	1	1989-05
	902-627	£38.00	BOOT, gear lever, lower, OEM	1	1989-05

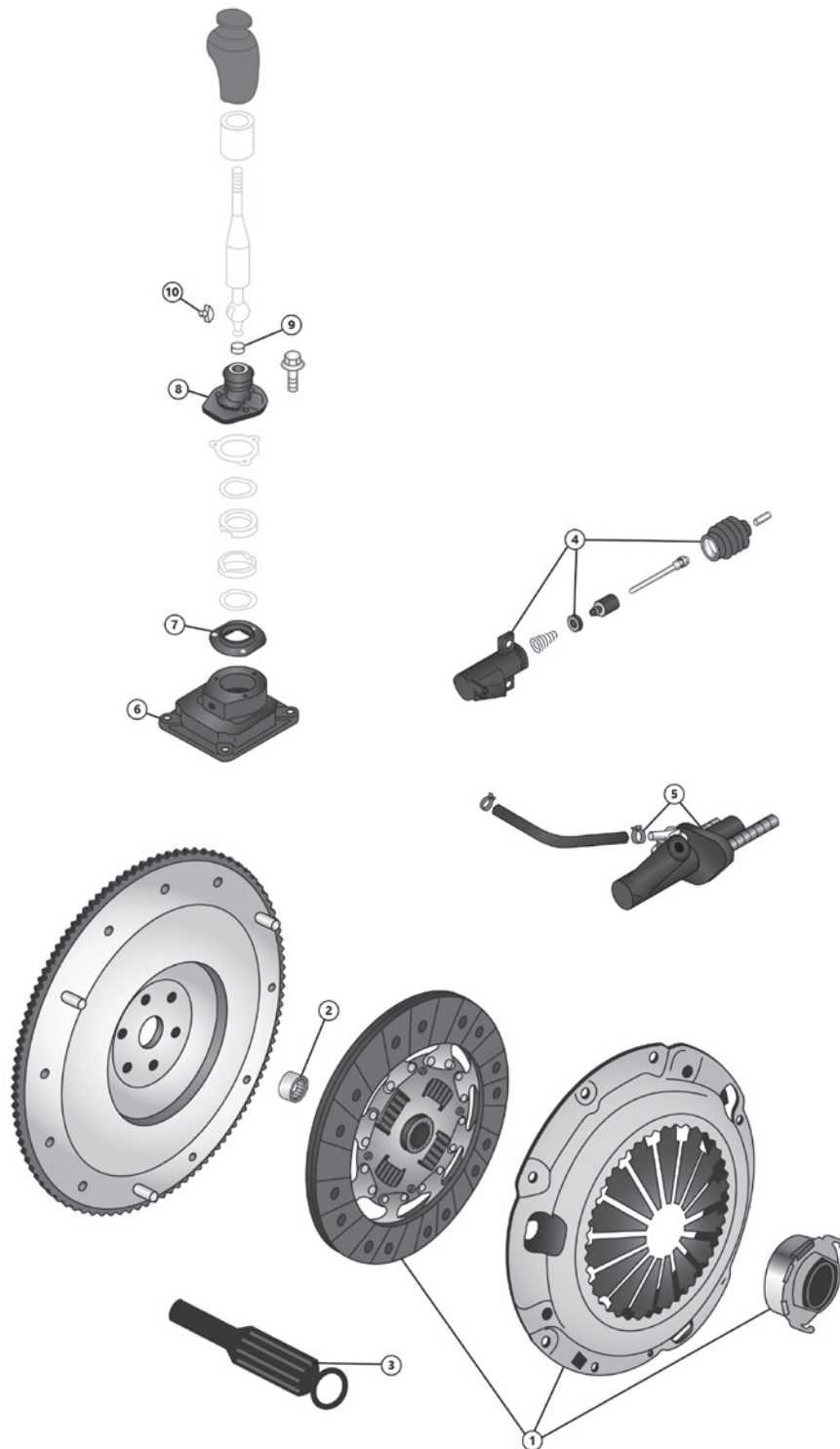

ill.	Part Number	Price £ea.	Description	Req.	Details
<b>Clutch &amp; Gearbox - Mk3</b>					
1	900-137	£185.00	CLUTCH KIT, Exedy	1	2006-15 5 speed
	900-138	£280.00	CLUTCH KIT, Exedy	1	2006-15 6 speed
2	901-862	£15.00	SPIGOT BEARING, OEM	1	2006-18
3	387-205	£7.90	CLUTCH ALIGNMENT TOOL	1	2006-15 5 speed
4	903-245	£53.50	SLAVE CYLINDER, clutch, OEM	1	2006-12
	903-247	£32.40	SLAVE CYLINDER, clutch NCA	1	2006-12
5	903-246	£123.70	MASTER CYLINDER, RHD, OEM	1	2006-12
	903-248	£67.80	MASTER CYLINDER, LHD, OEM	1	2006-12
6	903-476	£83.00	GAITER, gear lever, large, OEM	1	2006-15 5 speed
	910-389	£70.60	GAITER, gear lever, large	1	2006-15 5 speed
	903-477	£83.00	GAITER, gear lever, large, OEM	1	2006-15 6 speed
	910-388	£71.60	GAITER, gear lever, large	1	2006-15 6 speed
7	903-478	£27.00	LOCKOUT PLATE, reverse, OEM	1	2006-15 6 speed

ill.	Part Number	Price £ea.	Description	Req.	Details
8	903-475	£16.00	GAITER, gear lever, small, OEM	1	2006-15
9	907-183	£8.10	BUSH, gear lever, lower, OEM	1	2005-15 5 speed
	910-942	£19.50	BUSH, gear lever, lower, bronze	1	2005-15 5 speed
10	907-180	£13.00	BUSH, gear lever, OEM	1	2005-15 5 speed





ill.	Part Number	Price £ea.	Description	Req.	Details
<b>Front Suspension - Mk1-2.5</b>					
1	MXV10028	£53.00	HUB KIT, front	2	1989-05 ABS
	MXV10027	£30.00	HUB KIT, front	2	1989-05 non-ABS
2	902-400	NCA	TRACK ROD END, OEM	2	1989-05
	MXV8144	£32.30	TRACK ROD END	2	1989-97
3	905-970	£12.00	GAITER, track rod end, OEM	2	1989-05
4	902-270	£14.30	GAITER, ball joint, upper, OEM	2	1989-05
5	902-269	£9.80	GAITER, ball joint, lower, OEM	2	1989-05
6	901-025	£14.80	GAITER, damper, front	2	1989-93
	901-027	£39.00	GAITER, damper, front	2	1994-97
7	901-028	£19.00	GAITER, damper, front	2	1998-05
8	905-971	£130.10	TOP MOUNT, damper, OEM	2	1989-97
9	905-972	£30.40	TOP MOUNT, damper, OEM	2	1998-05
10	905-974	£2.00	WASHER, damper retaining, OEM	2	1998-05
11	905-975	£47.30	BUMP STOP, OEM	2	1998-05
12	905-977	£4.00	BUSH, damper, upper, OEM	2	1998-05
13	905-978	£4.00	BUSH, damper, lower, OEM	2	1998-05
14	903-973	£34.00	BUSH, lower, front, MazdaSpeed	2	1989-05
15	903-974	£52.00	BUSH, lower, rear, MazdaSpeed	2	1989-05
16	903-977	£52.00	BUSH, upper, inner, MazdaSpeed	4	1989-05
17	909-508	£124.00	GAITER, steering rack, OEM	2	1990-03
	909-505	£59.00	GAITER, steering rack, LH, OEM	1	non- power steering 1989-95
	909-506	£59.00	GAITER, steering rack, RH, OEM	1	power steering 1989-95
	902-635	£16.00	GAITER, steering rack, LH or RH	2	power steering 1989-95
	909-507	£92.00	GAITER, steering rack, set, OEM	1	power steering 1996-97
	902-636	£14.00	GAITER, steering rack, LH or RH	2	power steering 1996-97
18	902-268	£47.50	DROP LINK, anti-roll bar, OEM	2	1989-97
19	901-030	£11.00	BOLT, camber adjusting, OEM	4	1989-05 includes nut and washer
20	902-282	£99.70	DAMPER, front, KYB	2	1989-97
20	902-283	£97.80	DAMPER, front, KYB	2	1998-05
21	MXV10010	£15.00	TRACK ROD	2	1989-97
	MXV10011	£15.00	TRACK ROD	2	power steering 1989-97
	MX510050	£15.00	TRACK ROD, LH	1	non-power steering 1998-05
	MX510051	£15.00	TRACK ROD, RH	1	1998-05
22	MX510078	£90.60	WISHBONE, lower, LH	1	1998-05
	MX510079	£90.60	WISHBONE, lower, RH	1	1998-05
NI	MXV10043	£19.40	BALL JOINT, lower	2	1989-05
23	MX510047	£84.00	WISHBONE, upper, LH	1	1998-05 ABS
	MX510048	£84.00	WISHBONE, upper, RH	1	1998-05 ABS
	MX510049	£80.00	WISHBONE, upper, LH or RH	2	1998-05 non-ABS

**Rear Suspension - Mk1-2.5**

24	902-287	£94.30	DAMPER, rear, KYB	2	1989-97
	902-288	£105.70	DAMPER, rear, KYB	2	1998-05
25	902-272	£182.00	HUB, OEM	2	1989-05
26	902-271	NCA	BEARING, hub, OEM	2	1989-05
26	MXV10026	£26.00	BEARING, hub	2	1989-05
27	901-025	£14.80	GAITER, damper	2	1989-97
	901-027	£39.00	GAITER, damper, OEM	2	not sport suspension 1994-97
	901-028	£19.00	GAITER, damper, OEM	2	sport suspension 1998-05
29	905-971	£130.10	TOP MOUNT, damper, rear, OEM	2	1989-97
30	905-972	£30.40	TOP MOUNT, damper, rear, OEM	2	1998-05
31	905-974	£2.00	WASHER, damper retaining, OEM	2	1998-05
32	905-976	£42.20	BUMP STOP, rear, OEM	2	1998-05
33	905-977	£4.00	BUSH, damper, upper, OEM	2	1998-05
34	905-978	£4.00	BUSH, damper, lower, OEM	2	1998-05
35	903-978	NCA	BUSH, upper, inner & outer	6	1989-05 MazdaSpeed
36	903-979	£19.00	BUSH, lower, inner	4	1989-05 MazdaSpeed
37	903-980	£46.00	BUSH, lower, outer	4	1989-05 MazdaSpeed
38	903-145	£4.00	WHEEL NUTS, anodised, OEM	16	1989-05
	903-146	£7.00	WHEEL NUTS, chrome, OEM	16	1989-05
39	902-268	£47.50	DROP LINK, anti-roll bar, OEM	2	1989-97
40	901-030	£11.00	BOLT, camber adjusting, OEM (includes nut & washer)	8	1989-05

ill.	Part Number	Price £ea.	Description	Req.	Details
------	-------------	------------	-------------	------	---------

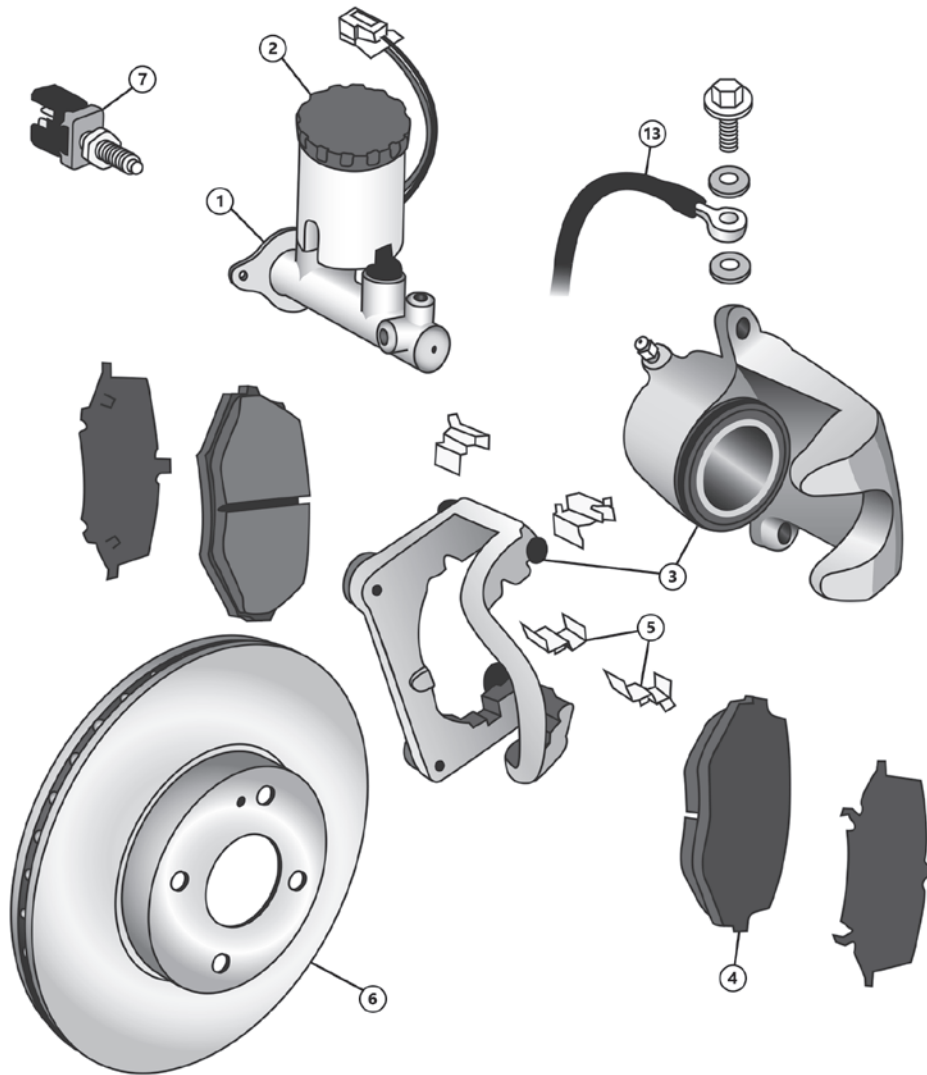

Front Brakes

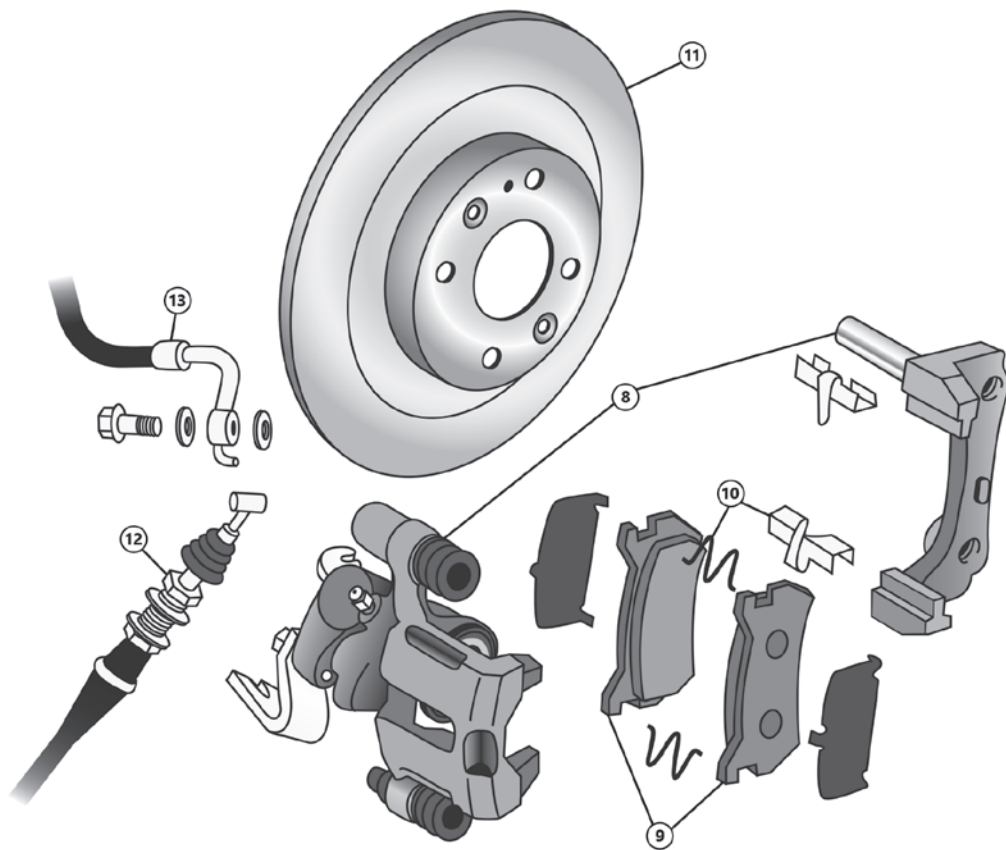

Rear Brakes

ill.	Part Number	Price £ea.	Description	Req.	Details	ill.	Part Number	Price £ea.	Description	Req.	Details
<b>Front Brakes - Mk1-2.5</b>											
1	NCA		MASTER CYLINDER, RHD, OEM	1	1989-97 without ABS	11	MXV10014	£10.00	BRAKE DISC, rear, single	2	1989-97 1.6
	NCA		MASTER CYLINDER, RHD, OEM	1	1989-97 with ABS		MXV10031	£10.00	BRAKE DISC, rear, single	2	1994-97 1.8
902-305	£165.00		MASTER CYLINDER, LHD, OEM	1	1989-97 without ABS		909-886	£30.00	BRAKE DISC, rear, single (276mm disc)	2	1998-05 1.6/1.8 1998-05 Big Brakes
902-310	£165.00		MASTER CYLINDER, LHD, OEM	1	1989-97 with ABS		901-055	£133.40	BRAKE DISC, rear, pair, DBA	1	1989-93
2	902-307	£23.00	CAP, brake master, OEM	1	1989-05		901-065	£154.40	BRAKE DISC, rear, pair, DBA	1	1994-97 1.8 1998-05 1.6/1.8
3	907-230	£75.60	CALIPER, front, LH (255mm disc)	1	1994-98 1.8 & 1998-05 1.6/1.8	12	901-075	£151.90	BRAKE DISC, rear, pair, DBA	1	1998-05 Big Brakes
	907-231	£75.60	CALIPER, front, RH (255mm disc)	1	1994-98 1.8 & 1998-05 1.6/1.8		971-195	£35.00	CABLE, handbrake, front, OEM	1	1989-05
	907-247	£95.00	CALIPER, front, pair (255mm disc)	1	1994-98 1.8 & 1998-05 1.6/1.8		904-561	NCA	CABLE, handbrake, rear, LH, OEM	1	1989-97 1.6
	904-450	£82.00	SEAL KIT, caliper, front, OEM	1	1989-97 1.6		904-560	NCA	CABLE, handbrake, rear, RH, OEM	1	1989-97 1.6
4	MXV8135	£23.80	PAD SET, front, EBC, Ultimax	1	1989-97 1.6		905-231	£39.00	CABLE, handbrake, rear, LH	1	1989-97 1.6
	MXV1270G	£61.80	PAD SET, front, EBC, Greenstuff	1	1989-97 1.6		905-230	£39.00	CABLE, handbrake, rear, RH	1	1989-97 1.6
	MXV1270R	£73.60	PAD SET, front, EBC, Redstuff	1	1989-97 1.6		905-232	£24.00	CABLE, handbrake, rear, RH	1	1994-97 1.8 1998-05 1.6/1.8
	MXV1270Y	£88.70	PAD SET, front, EBC, Yellowstuff	1	1989-97 1.6	13	GBL902121	£91.20	HOSE SET, braided, silver	1	1989-05 Goodridge
	901-550	£132.00	PAD SET, front, Hawk, HP Plus	1	1989-97 1.6		GBL902131	£91.20	HOSE SET, braided, red	1	1989-05 Goodridge
	MXV8136	£25.90	PAD SET, front, EBC, Ultimax (255mm disc)	1	1994-97 1.8 & 1998-05 1.6/1.8		GBL902122	£123.00	HOSE SET, braided, clear	1	1989-05 Goodridge
	MXV1272G	£70.30	PAD SET, front, EBC, Greenstuff (255mm disc)	1	1994-97 1.8 & 1998-05 1.6/1.8	NI	MXV11011	£92.50	PIPE SET, copper, Automec	1	1989-97 without ABS
	MXV1272R	£87.60	PAD SET, front, EBC, Redstuff (255mm disc)	1	1994-97 1.8 & 1998-05 1.6/1.8		MXV11012	£92.50	PIPE SET, copper, Automec	1	1989-97 with ABS
	MXV1272Y	£107.10	PAD SET, front, EBC, Yellowstuff (255mm disc)	1	1994-97 1.8 & 1998-05 1.6/1.8						
	901-560	£137.30	PAD SET, front, Hawk, HP Plus (255mm disc)	1	1994-97 1.8 & 1998-05 1.6/1.8						
	MX51272G	£69.20	PAD SET, front, EBC, Greenstuff (270mm disc)	1	1998-05 Big Brake						
	MX51272R	£87.60	PAD SET, front, EBC, Redstuff (270mm disc)	1	1998-05 Big Brake						
	MX51272Y	£110.35	PAD SET, front, EBC, Yellowstuff (270mm disc)	1	1998-05 Big Brake						
5	904-825	£11.10	CLIP, brake pads, set, OEM	1	1989-97 1.6						
	904-826	£16.80	CLIP, brake pads, set, OEM	1	1994-97 1.8 & 1998-05 1.6/1.8						
	904-828	NCA	CLIP, brake pads, set, OEM	1	1998-05 Big Brake						
6	MXV10013	£12.00	BRAKE DISC, front	2	1989-97 1.6						
	MXV10032	£12.00	BRAKE DISC, front	2	1994-97 1.8 & 1998-05 1.6/1.8						
	909-885	£30.00	BRAKE DISC, front	2	1998-05 Big Brakes						
	901-050	£152.10	BRAKE DISC, front, pair, DBA	1	1989-97 1.6						
	901-060	£154.40	BRAKE DISC, front, pair, DBA	1	1994-97 1.8 1998-05 1.6/1.8						
	901-070	£195.70	BRAKE DISC, front, pair, DBA (270mm disc)	1	1998-05 Big Brakes						
7	902-385	£19.00	SWITCH, brake light, OEM	1	1989-97						
	902-386	£9.00	SWITCH, brake light	1	1989-97						
<b>Rear Brakes - Mk1-2.5</b>											
8	904-486	£179.00	CALIPER, rear, LH, rebuilt, OEM	1	1989-97 1.6						
	904-485	£179.00	CALIPER, rear, RH, rebuilt, OEM	1	1989-97 1.6						
	907-245	£76.70	CALIPER, rear, LH, new	1	1994-97 1.8 1998-05 1.6/1.8						
	907-246	£76.70	CALIPER, rear, LH, new	1	1994-97 1.8 1998-05 1.6/1.8						
	907-248	NCA	Caliper, rear, pair, new	1	1994-97 1.8 1998-05 1.6/1.8						
	904-451	£60.00	SEAL KIT, caliper, rear, OEM	1	1989-05						
9	MXV8138	£17.40	PAD SET, rear, EBC, Ultimax	1	1989-93						
	MXV1271G	£53.00	PAD SET, rear, EBC, Greenstuff	1	1989-93						
	MXV1271R	£69.30	PAD SET, rear, EBC, Redstuff	1	1989-93						
	MXV1271Y	£70.50	PAD SET, rear, EBC, Yellowstuff	1	1989-93						
	901-555	£133.20	PAD SET, rear, Hawk, HP Plus	1	1989-93						
	MXV8137	£23.80	PAD SET, rear, EBC, Ultimax (255mm disc)	1	1994-97 1.8 1998-05 1.6/1.8						
	MXV1273G	£61.70	PAD SET, rear, EBC, Greenstuff (255mm disc)	1	1994-97 1.8 1998-05 1.6/1.8						
	MXV1273R	£70.30	PAD SET, rear, EBC, Redstuff (255mm disc)	1	1994-97 1.8 1998-05 1.6/1.8						
	MXV1273Y	£84.30	PAD SET, rear, EBC, Yellowstuff (255mm disc)	1	1994-97 1.8 1998-05 1.6/1.8						
	901-565	£143.20	PAD SET, rear, Hawk, HP Plus (255mm disc)	1	1994-97 1.8 1998-05 1.6/1.8						
	MX51273G	£51.90	PAD SET, rear, EBC, Greenstuff (276mm disc)	1	1998-05 Big Brake						
	MX51273R	£68.10	PAD SET, rear, EBC, Redstuff (276mm disc)	1	1998-05 Big Brake						
	MX51273Y	£90.80	PAD SET, rear, EBC, Yellowstuff (276mm disc)	1	1998-05 Big Brake						
10	904-829	£11.90	CLIP, brake pads, rear, OEM	1	1989-97 1.6						
	904-830	£7.80	CLIP, brake pads, rear, OEM	1	1994-97 1.8 1998-05 1.6/1.8						

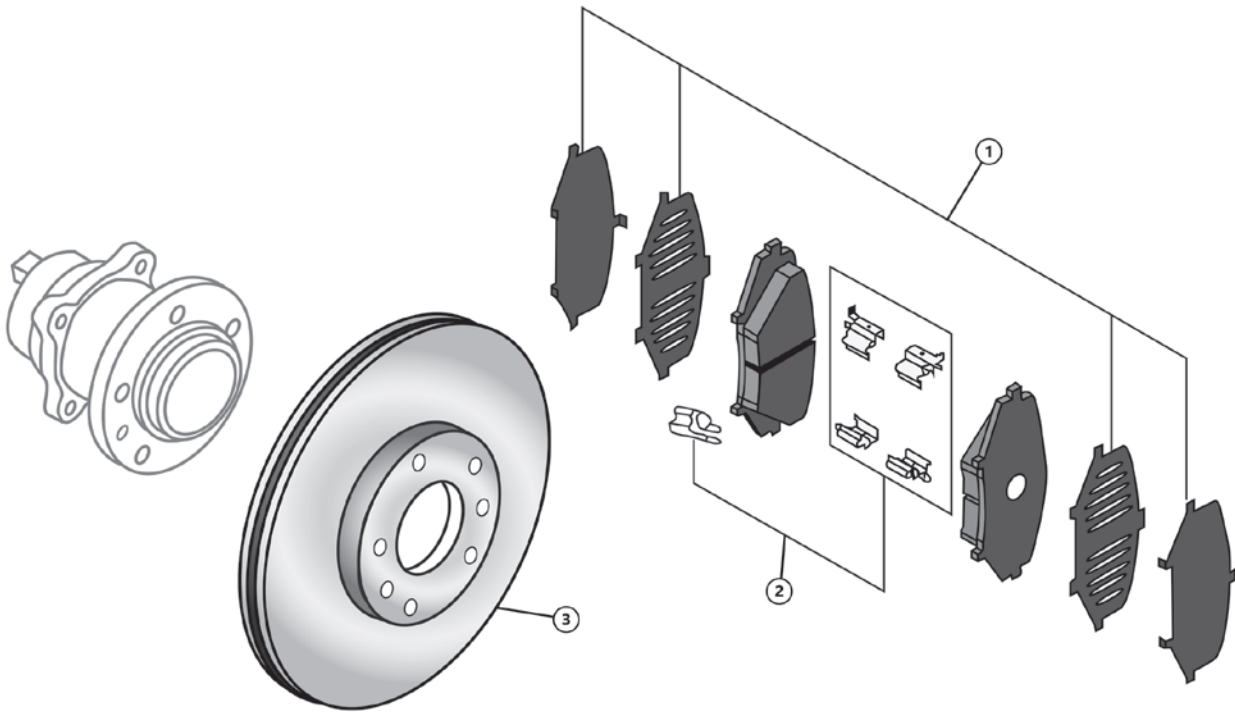

Front Brakes

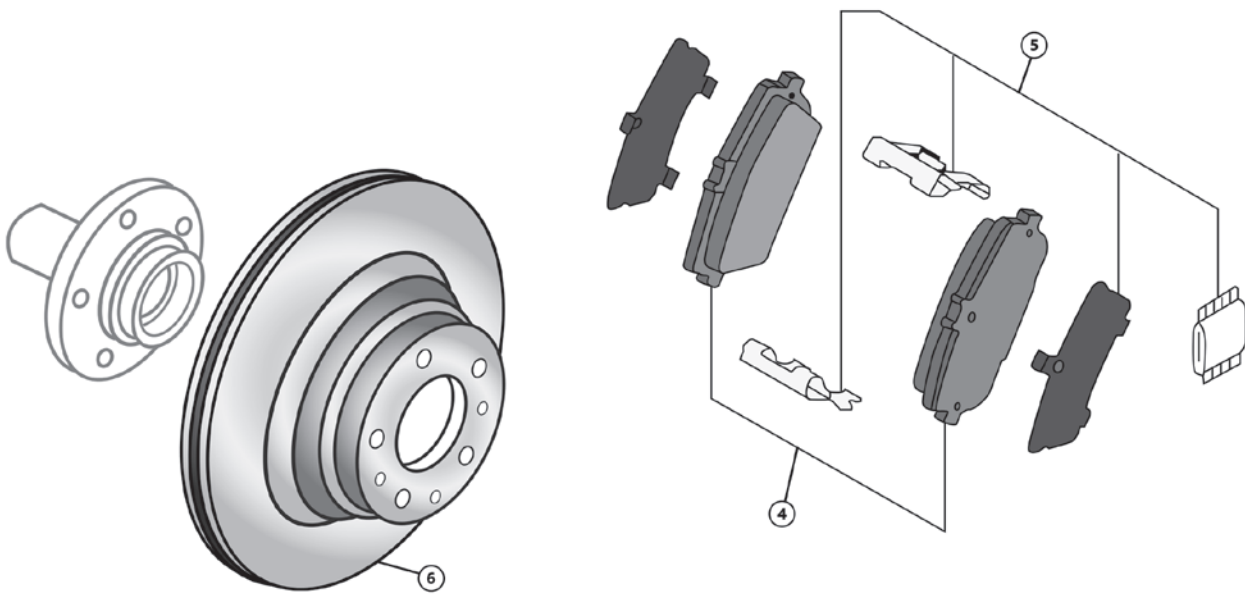

Rear Brakes

ill.	Part Number	Price £ea.	Description	Req.	Details
------	-------------	------------	-------------	------	---------

**Front Brakes - Mk3**

1	MXV310090	£14.00	PAD SET, front	1	2006-15
	903-641	£28.00	PAD SET, front, cerametallic	1	2006-15
	MXV1274G	£75.80	PAD SET, front, EBC, Greenstuff	1	2006-15
	916-185	£134.80	PAD SET, front, Hawk, HP Plus	1	2006-15
2	903-460	£14.00	CLIP, brake pads, front	1	2006-15
3	MXV310089	£18.00	BRAKE DISC, front	2	2006-15
	904-692	£198.80	BRAKE DISC, front, DBA	1	2006-15

**Rear Brakes - Mk3**

4	MXV310103	£16.00	PAD SET, rear	1	2006-15
	903-642	£29.30	PAD SET, rear, cerametallic	1	2006-15
	MXV1275G	£70.30	PAD SET, rear, EBC, Greenstuff	1	2006-15
	916-185	£134.80	PAD SET, rear, Hawk, HP Plus	1	2006-15
5	903-461	£12.00	CLIP, brake pads, rear	1	2006-15
6	MXV310088	£12.00	BRAKE DISC, rear	2	2006-15
	904-690	£177.50	BRAKE DISC, rear, DBA	1	2006-15
NI	GBL902123	£100.70	HOSE SET, braided, clear	1	2006-15
					Goodridge
NI	GBL902133	£100.70	HOSE SET, braided, red	1	2006-15
					Goodridge

ill.	Part Number	Price £ea.	Description	Req.	Details
------	-------------	------------	-------------	------	---------

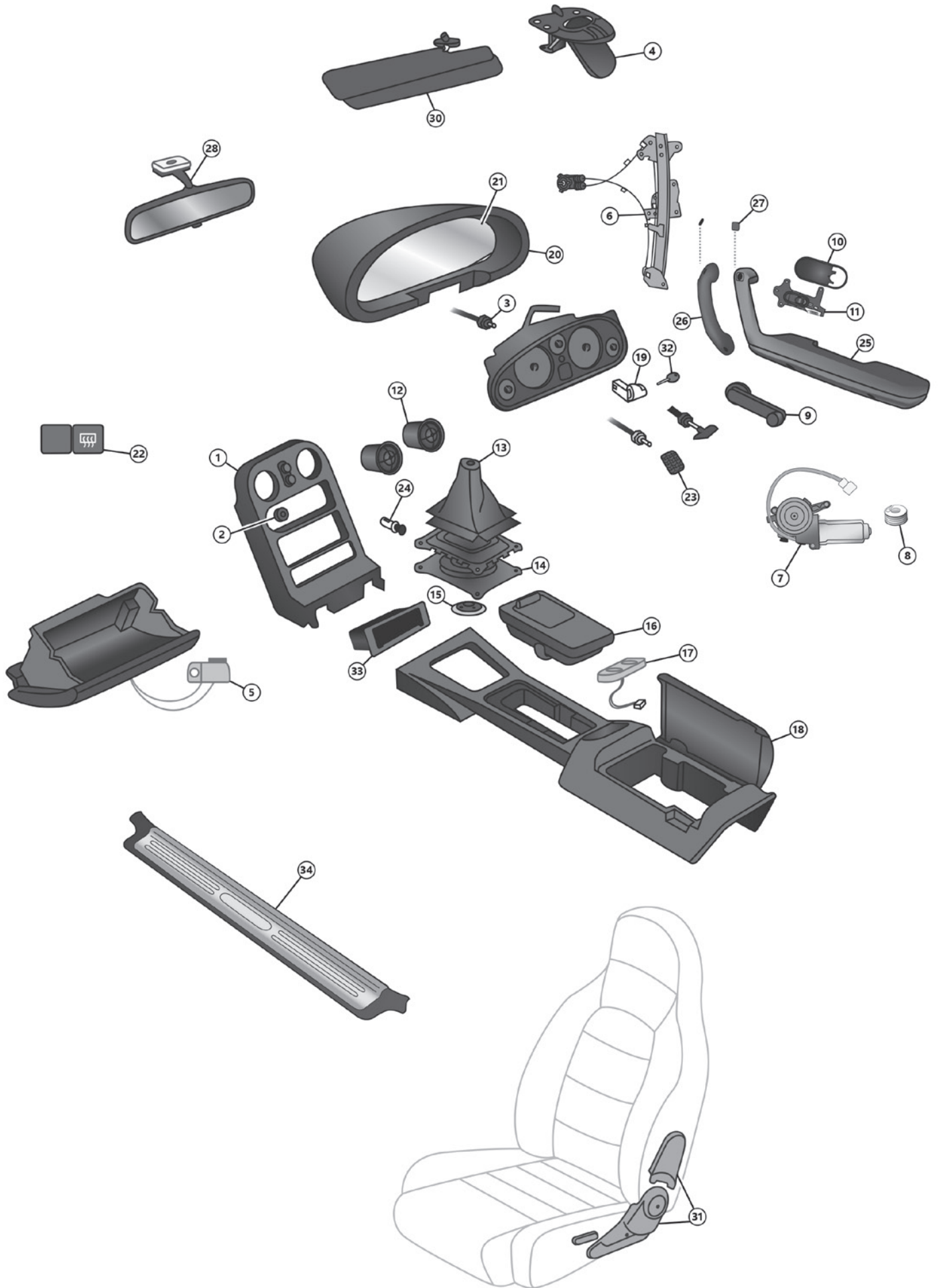

ill.	Part Number	Price £ea.	Description	Req.	Details
<b>Interior Fittings - Mk1-2.5</b>					
1	902-425	£160.70	Surround, Radio, OEM	1	1989-93
	909-940	£78.00	Surround, Radio	1	1989-93
	902-435	£115.00	Surround, Radio, w/CD, OEM	1	1994-97
					with CD changer
2	902-915	£28.10	BUTTON, AC, OEM	1	1989-97
3	904-452	£103.00	CABLE, speedo, 5 speedo, OEM	1	1989-97
4	903-235	£165.00	LATCH, soft top, LH, OEM	1	1989-02
	903-236	£165.00	LATCH, soft top, RH OEM	1	1989-02
	902-945	£187.00	LATCH, soft top, LH, OEM	1	2003-05
	902-946	£187.00	LATCH, soft top, RH, OEM	1	2003-05
5	904-455	£22.00	HANDLE, glovebox, black, OEM	1	1994-97
	904-454	£22.00	HANDLE, glovebox, tan, OEM	1	1994-97
6	MXV3020XL	£146.10	REGULATOR, LH, OEM	1	1989-97
					electric window
	MXV3020XR	£146.10	REGULATOR, RH, OEM	1	1989-97
					electric window
	907-129	£138.80	REGULATOR, LH, OEM	1	1989-97
					manual window
	907-130	£110.70	REGULATOR, RH, OEM	1	1989-97
					manual window
7	907-136	£320.00	MOTOR, electric window, LH, OEM	1	1989-97
	907-137	£320.00	MOTOR, electric window, RH, OEM	1	1989-97
	907-138	£260.00	MOTOR, electric window, LH, OEM	1	1989-05
	907-139	£260.00	MOTOR, electric window, RH, OEM	1	1998-05
	907-260	£115.00	MOTOR, electric window, LH	1	1998-05
	907-261	£115.00	MOTOR, electric window, RH	1	1998-05
8	907-115	£6.00	BUSH, regulator, LH, OEM	1	1989-97
	907-131	£6.00	BUSH, regulator, RH, OEM	2	1989-97
9	902-445	£15.30	CRANK, window, OEM	2	1989-94
10	902-935	£9.40	CUP, door handle, OEM	2	1989-97
11	902-936	NCA	DOOR LOCK & HANDLE, LH, OEM	1	1989-97
	902-937	NCA	DOOR LOCK & HANDLE, RH, OEM	1	1989-97
12	907-132	£50.60	VENT, eyeball, black, OEM	4	1989-03
	907-133	NCA	VENT, eyeball, silver, OEM	4	2001-03
13	MXV1013X	£33.90	GAITER, gear lever, leather	1	1989-97
	900-657	£29.00	GAITER, gear lever, leather	1	1998-05
14	902-625	£31.00	INSULATOR, upper, OEM	1	1989-05
	994-010	£14.90	INSULATOR, upper	1	1989-05
15	902-627	£38.00	INSULATOR, lower, OEM	1	1989-93
	902-626	£52.00	INSULATOR, lower, OEM	1	1994-05
	770-823	£18.20	INSULATOR, lower	1	1989-05
16	903-230	£84.20	ASHTRAY, black, OEM	1	1989-97
	MXV1170Z	£20.30	CUP HOLDER	1	1989-97
17	904-456	£136.00	SWITCH, window, OEM	1	1989-97
					manual transmission
	904-457	£81.00	SWITCH, window, OEM	1	1989-97
					automatic transmission
	902-890	£74.60	SWITCH, window, black, OEM	1	1998-00
	903-880	£129.00	SWITCH, window, black, OEM	1	2001-05
	902-891	£68.00	SWITCH, window, tan, OEM	1	1998-00
	903-881	£119.00	SWITCH, window, tan, OEM	1	2001-02
18	650-209	£99.00	CONSOLE LID, black, OEM	1	1989-97
	650-208	£99.00	CONSOLE LID, black, OEM	1	1998-00
	650-207	£67.00	CONSOLE LID, black, OEM	1	2001-05
19	901-920	£79.30	IGNITION SWITCH, OEM	1	1989-97
	908-173	£50.00	IGNITION SWITCH, OEM	1	1998-05
20	903-240	£166.90	GAUGE HOOD, LHD, OEM	1	1989-93
	903-243	£79.00	GAUGE HOOD, LHD	1	1989-93
	903-241	£159.30	GAUGE HOOD, LHD, OEM	1	1994-97
21	902-920	£115.00	WINDOW, gauge hood, OEM	1	1989-95
22	904-458	£75.00	SWITCH, heated rear window, OEM	1	1992-97
23	902-940	£6.20	PAD, brake & clutch pedal, OEM	2	1989-05
24	904-785	£42.00	CIGARETTE LIGHTER, OEM	1	1989-97
	904-787	£35.00	CIGARETTE LIGHTER, OEM	1	2001-05
25	907-150	£63.00	ARMREST, LH, black, OEM	1	1989-93
	907-150	£63.00	ARMREST, LH, black, OEM	1	1996-97
	907-151	£63.00	ARMREST, RH, black, OEM	1	1989-93
	907-151	£63.00	ARMREST, RH, black, OEM	1	1996-97
26	907-155	£49.00	DOOR PULL, RH, black, OEM	1	1994-95
27	907-157	£3.00	CAP, armrest, RH, black, OEM	1	1989-97
28	902-830	£92.40	MIRROR, interior, OEM	1	1989-95
30	908-030	£105.00	SUNVISOR, LH, OEM	1	1989-93
31		NCA	COVER, upper mech, blk, LH, OEM	1	1989-97
		NCA	COVER, lower mech, blk, RH, OEM	1	1989-97
32	905-875	£15.00	KEY BLANK, OEM	1	1989-93
	905-877	£12.00	KEY BLANK, OEM	1	1999-03
	905-877	£12.00	KEY BLANK, immobiliser, OEM	1	2001-03
33	905-275	£20.40	CUBBY TRAY	1	1989-97
	904-467	£15.00	CUBBY TRAY, OEM	1	1999-01
34	MXV1210X	£86.70	KICKPLATE, sill, stainless, MX-5	1	1989-97
	971-461	£214.10	KICKPLATE, sill, black, Miata, OEM	1	1998-05
	971-462	£122.00	KICKPLATE, sill, tan, Miata, OEM	1	1999-02

ill.	Part Number	Price £ea.	Description	Req.	Details
------	-------------	------------	-------------	------	---------

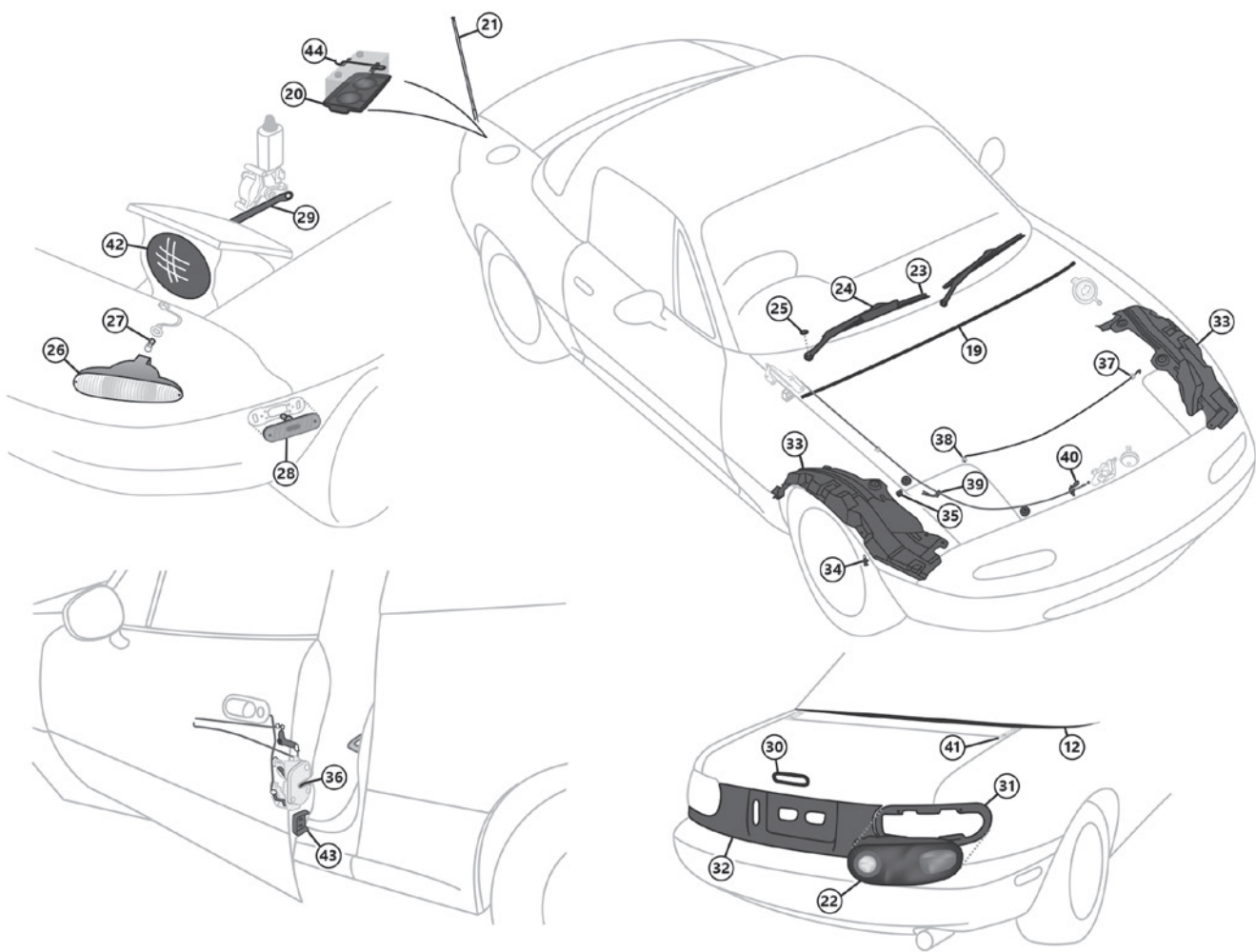
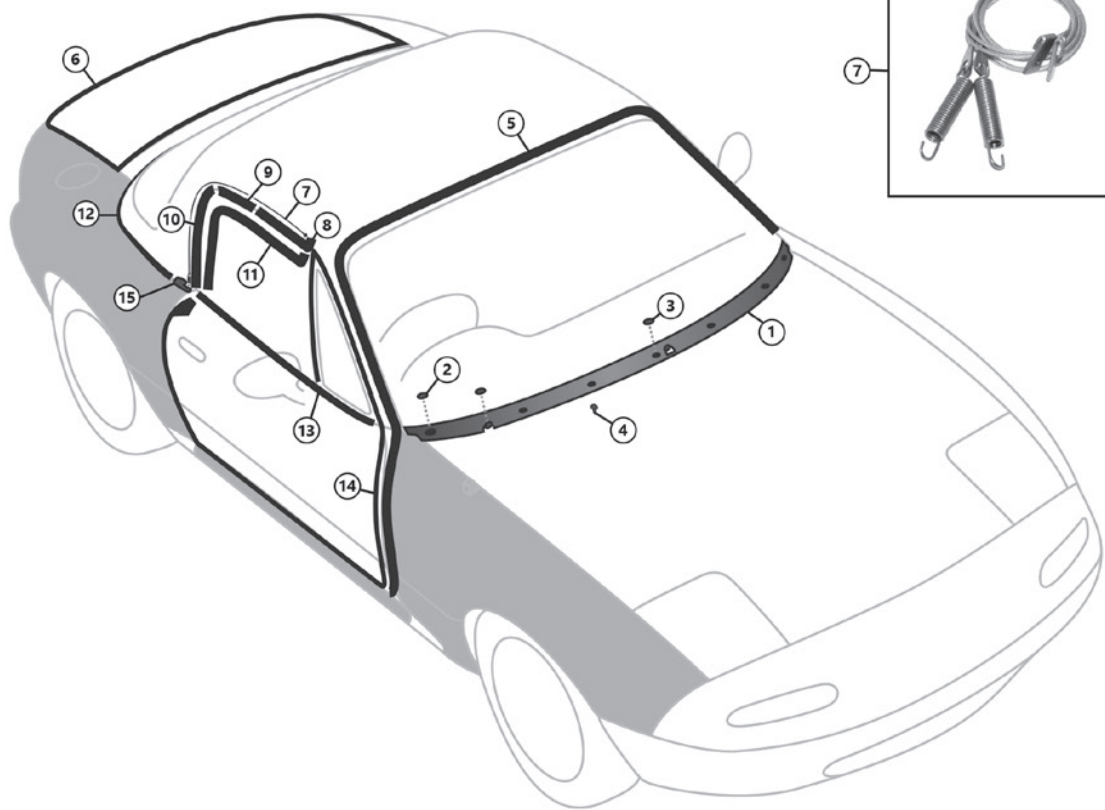



ill.	Part Number	Price £ea.	Description	Req.	Details
<b>External Body Fittings - Mk1-2.5</b>					
1			NCA COWL, windscreen, RHD, OEM	1	1989-05
	902-485		NCA COWL, windscreen, LHD, OEM	1	1989-05
	909-865	£115.00	COWL, windscreen, LHD	1	1989-05
2	902-484	£2.70	PLUG, cowl, outer, OEM	2	1989-05
3	902-487	£2.00	PLUG, cowl, inner, OEM	5	1989-05
4	902-405	£22.00	WASHER JET, OEM	2	1989-97
5	904-815	£222.00	SEAL, windscreen, OEM	1	1989-97
	904-816	£202.00	SEAL, windscreen, OEM	1	1998-05
	904-817	£58.00	SEAL, windscreen	1	1989-97
6	904-426	NCA	SEAL, boot, OEM	1	1989-97
7	240-246	£53.80	HOOD CABLES, pair	1	1989-97
	240-247	£62.50	HOOD CABLES, pair	1	1998-05
8	909-855	£115.10	ROOF SEALS, set	1	1989-05
	902-521	£48.00	ROOF SEAL, front, LH, OEM	1	1989-97
	902-520	NCA	ROOF SEAL, front, RH, OEM	1	1989-97
	903-620	£62.00	ROOF SEAL, front, LH, OEM	1	1998-05
	903-623	£58.00	ROOF SEAL, front, RH, OEM	1	1998-05
9	902-523	NCA	ROOF SEAL, middle, LH, OEM	1	1989-97
	902-522	£35.00	ROOF SEAL, middle, RH, OEM	1	1989-97
	903-621	£35.00	ROOF SEAL, middle, LH, OEM	1	1998-05
9	903-624	£55.00	ROOF SEAL, middle, RH, OEM	1	1998-05
10	902-525	£48.00	ROOF SEAL, rear, LH, OEM	1	1989-97
	902-524	£48.00	ROOF SEAL, rear, RH, OEM	1	1989-97
	903-622	NCA	ROOF SEAL, rear, LH, OEM	1	1998-05
	903-625	£70.00	ROOF SEAL, rear, RH, OEM	1	1998-05
11	901-490	£80.00	WINDOW SEAL, hardtop, RH, OEM	1	1989-05
	901-491	£80.00	WINDOW SEAL, hardtop, LH, OEM	1	1989-05
12	901-494	£98.00	SEAL, hardtop, rear	1	1989-05
	910-391	£78.00	RAIN RAIL	1	1989-05
	240-245	£107.50	RAIN RAIL	1	1989-05
					I.L. Motorsport
					Robbins
13	902-429	£109.30	SEAL, door to glass, LH, OEM	1	1989-05
	902-428	£109.30	SEAL, door to glass, RH, OEM	1	1989-05
	909-692	£100.00	SEAL, door to glass, pair	1	1989-05
	909-693	£4.50	CLIP, door to glass seal, mid, OEM	8	1989-05
	909-694	£4.50	CLIP, door to glass seal, end, OEM	4	1989-05
14	904-427	NCA	SEAL, door, LH, OEM	1	1989-97
	904-428	NCA	SEAL, door, RH, OEM	1	1989-97
15	902-527	NCA	RETAINER, B-pillar, LH, OEM	1	1989-97
	902-526	NCA	RETAINER, B-pillar, RH, OEM	1	1989-97
	903-610	£70.60	RETAINER, B-pillar, LH, OEM	1	1998-05
19	904-425	NCA	SEAL, bonnet, OEM	1	1989-97
20	902-854	NCA	BATTERY TRAY, OEM	1	1989-97
	902-868	£26.00	BATTERY TRAY	1	1998-05
21	902-475	£35.90	AERIAL, electric, OEM	1	1989-97
	902-476	£50.50	AERIAL, electric, OEM	1	1998-05
22	902-473	£230.00	TAIL LAMP, LH, OEM	1	1989-97
	902-472	£185.00	TAIL LAMP, RH, OEM	1	1998-00
	902-474	£230.00	TAIL LAMP, LH, OEM	1	1998-00
23	902-195	£5.50	WIPER BLADE	2	1989-05
24		NCA	WIPER ARM, LH, RHD, OEM	1	1989-97
		NCA	WIPER ARM, RH, RHD, OEM	1	1989-97
	902-905	£54.00	WIPER ARM, LH, LHD, OEM	1	1989-97
	902-906	£54.00	WIPER ARM, RH, LHD, OEM	1	1989-97
25	902-910	NCA	CAP, wiper arm, OEM	2	1989-05
26	902-464	£104.00	INDICATOR HOUSING, LH, US spec	1	1989-97
	902-469	£104.00	INDICATOR HOUSING, RH, US spec	1	1989-97
27	170-700	£0.20	BULB, Indicator, US spec	2	1989-97
28	903-630	£45.00	LAMP, side marker, lh, OEM	1	1990-01
29	904-965	£20.00	ROD, headlamp retractor, OEM	2	1989-97
30	905-240	£24.00	SEAL, brake light, boot lid	1	1989-97
31	905-242	£13.40	SEAL, tail lamp, OEM	2	1989-97
32	906-130	NCA	FINISH PANEL, rear, US/import	1	1989-97
33	907-390	£85.00	ARCH LINER, front, LH, OEM	1	1989-97
	907-391	£85.00	ARCH LINER, front, RH, OEM	1	1989-97
34	907-392	£4.00	FASTENER, arch liner, OEM	10	1989-97
35	907-393	£3.00	CLIP, arch liner, OEM	10	1989-97
36	908-046	£116.00	DOOR LATCH, RH, OEM	1	1989-97
37	908-073	£4.00	HOLDER, bonnet rod, front, OEM	1	1989-97
38	908-074	£4.00	HOLDER, bonnet rod, rear, OEM	1	1989-97
39	908-075	£4.00	HOLDER, bonnet release, OEM	1	1989-97
40	908-077	£10.00	FASTENER, bonnet release, OEM	1	1989-97
41	909-500	£26.00	BOLT, hardtop, OEM	2	1989-05
	909-995	£14.00	BOLT, hardtop	2	1989-05
	909-501	£51.00	BOLT, hardtop, OEM	2	2006-08
42	GAC4022	£44.50	ASSEMBLY, headlamp	2	1989-97
	GLB472	£5.40	BULB, headlamp	2	1989-97
43	910-804	£8.10	LATCH, dovetail, OEM	2	1990-18
44	908-171	£31.00	TIE-DOWN, battery, OEM	1	1989-97
	908-172	£31.00	TIE-DOWN, battery, OEM	1	1998-05

ill.	Part Number	Price £ea.	Description	Req.	Details
------	-------------	------------	-------------	------	---------

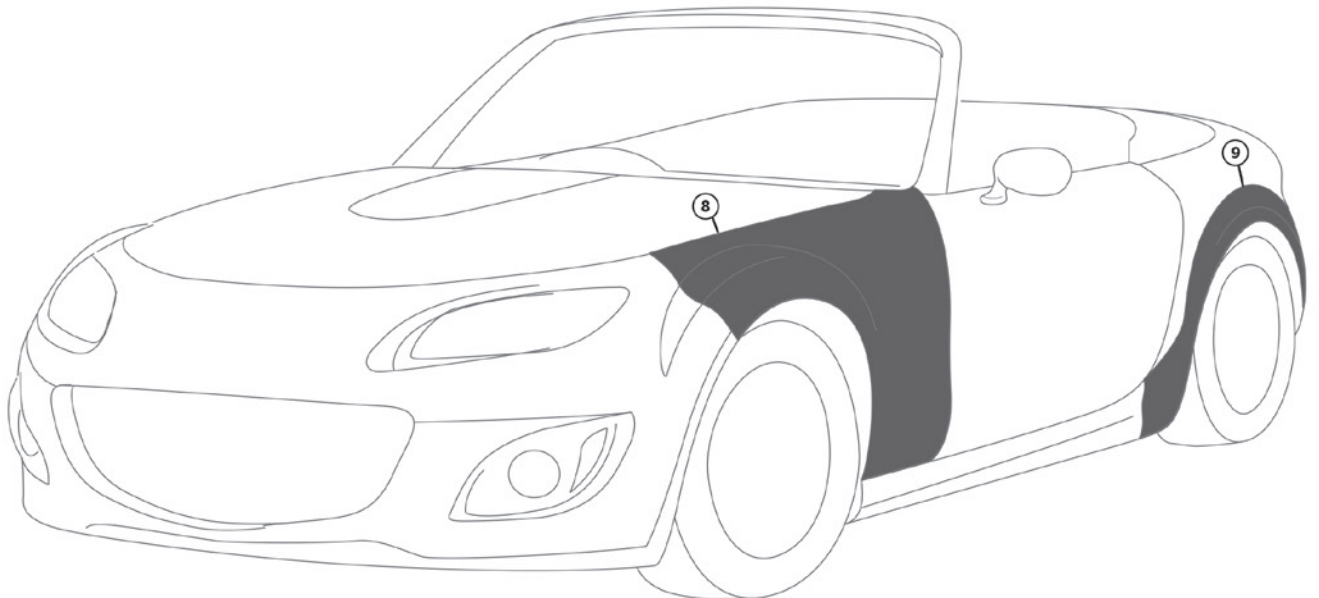
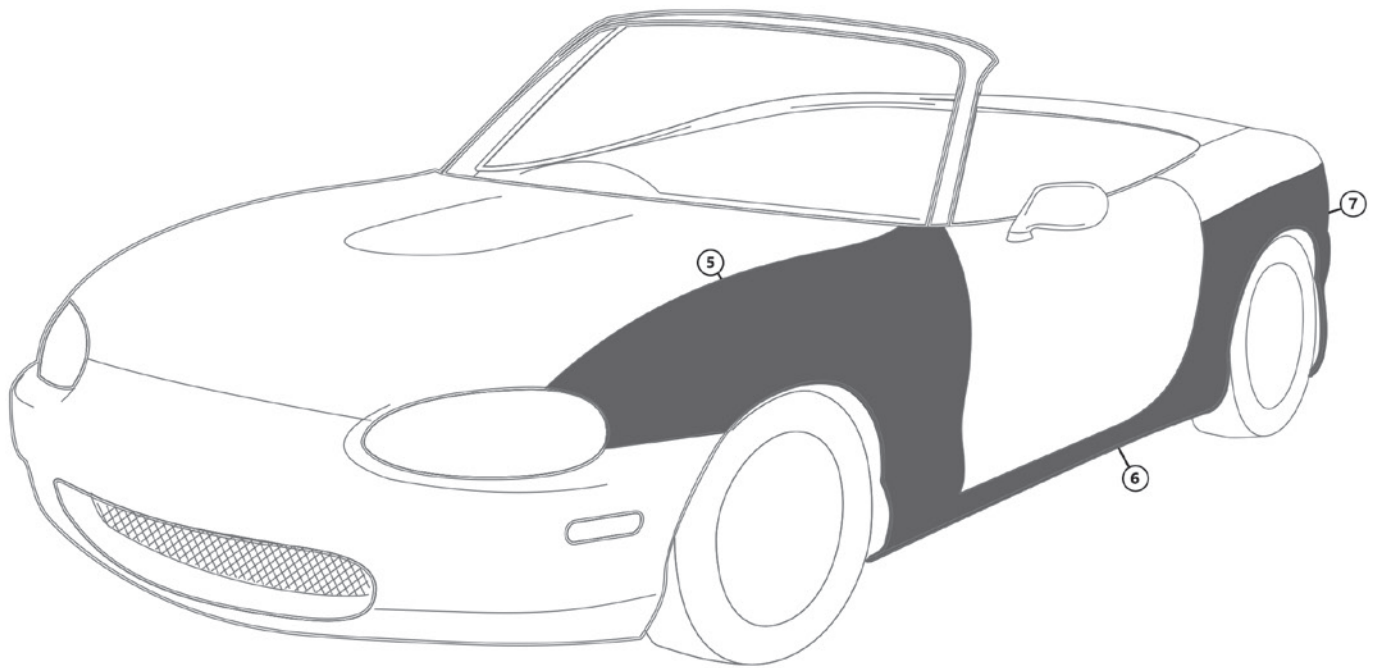
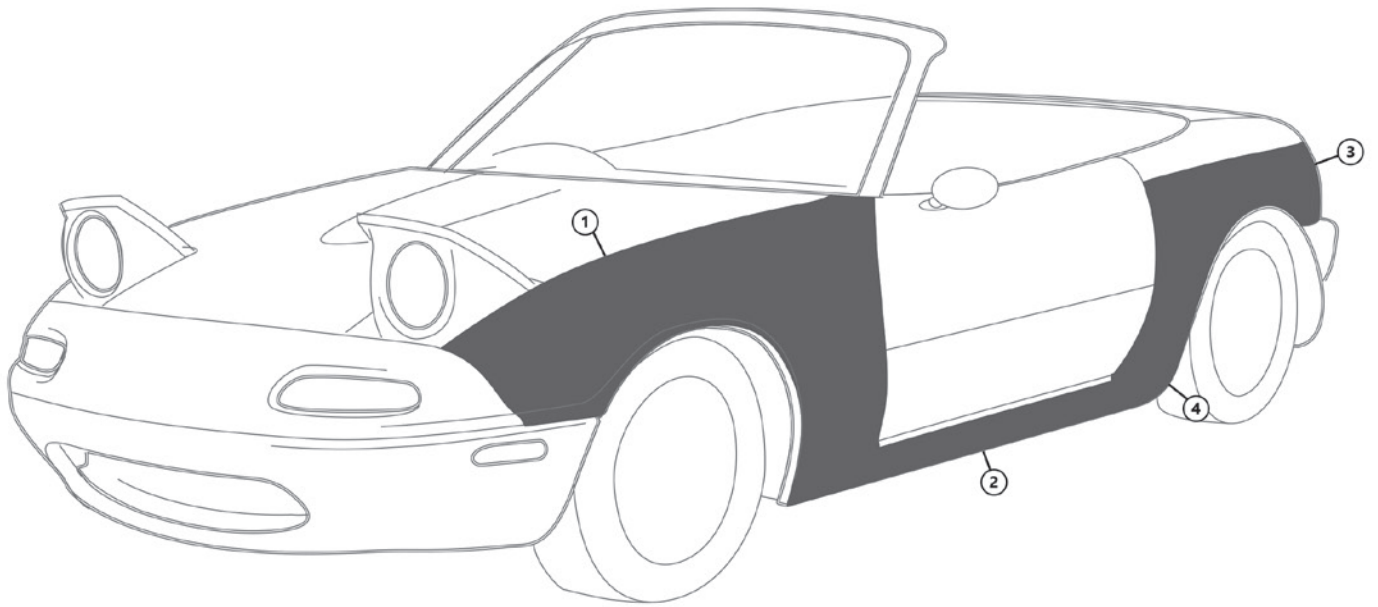

ill.	Part Number	Price £ea.	Description	Req.	Details
<b>Body Panels - Mk1</b>					
1	MXV3023	£109.80	WING, front, LH	1	1989-97
	MXV3024	£109.80	WING, front, RH	1	with repeater holes
	MXV3023US	£162.40	WING, front, LH	1	1989-97 UK/ EU Spec
	MXV3024US	£162.40	WING, front, RH	1	with repeater holes
2	MXV30341	£79.20	SILL PANEL, LH	1	1989-97 US Spec
	MXV30351	£79.20	SILL PANEL, RH	1	without repeater holes
3	MXV3026	£73.20	REPAIR PANEL, rear arch, LH	1	1989-97 US Spec
	MXV3027	£73.20	REPAIR PANEL, rear arch, RH	1	without repeater holes
4	MXV3038	£73.20	REPAIR PANEL, mudguard, LH	1	1989-97 US Spec
	MXV3039	£78.30	REPAIR PANEL, mudguard, RH	1	without repeater holes

**Body Panels - Mk2-2.5**

5	MX53029	£183.00	WING, front, LH	1	1998-05 US Spec
	MX53030	£183.00	WING, front, RH	1	without repeater holes
6	MXV30361	£85.50	SILL PANEL, LH	1	1998-05 US Spec
	MXV30371	£85.50	SILL PANEL, RH	1	without repeater holes
7	MXV3032	£88.50	REPAIR PANEL, rear arch, LH	1	1998-05
	MXV3033	£88.50	REPAIR PANEL, rear arch, RH	1	1998-05

**Body Panels - Mk3**

8	MXV3045	£186.00	WING, front, LH	1	2005-15
	MXV3044	£186.00	WING, front, RH	1	2005-15
9	MXV3042	£86.00	REPAIR PANEL, rear arch, LH	1	2005-15
	MXV3043	£86.00	REPAIR PANEL, rear arch, RH	1	2005-15

ill.	Part Number	Price £ea.	Description	Req.	Details
------	-------------	------------	-------------	------	---------

# DYNOLITE

EUROPE'S CLASSIC MOTOR OIL

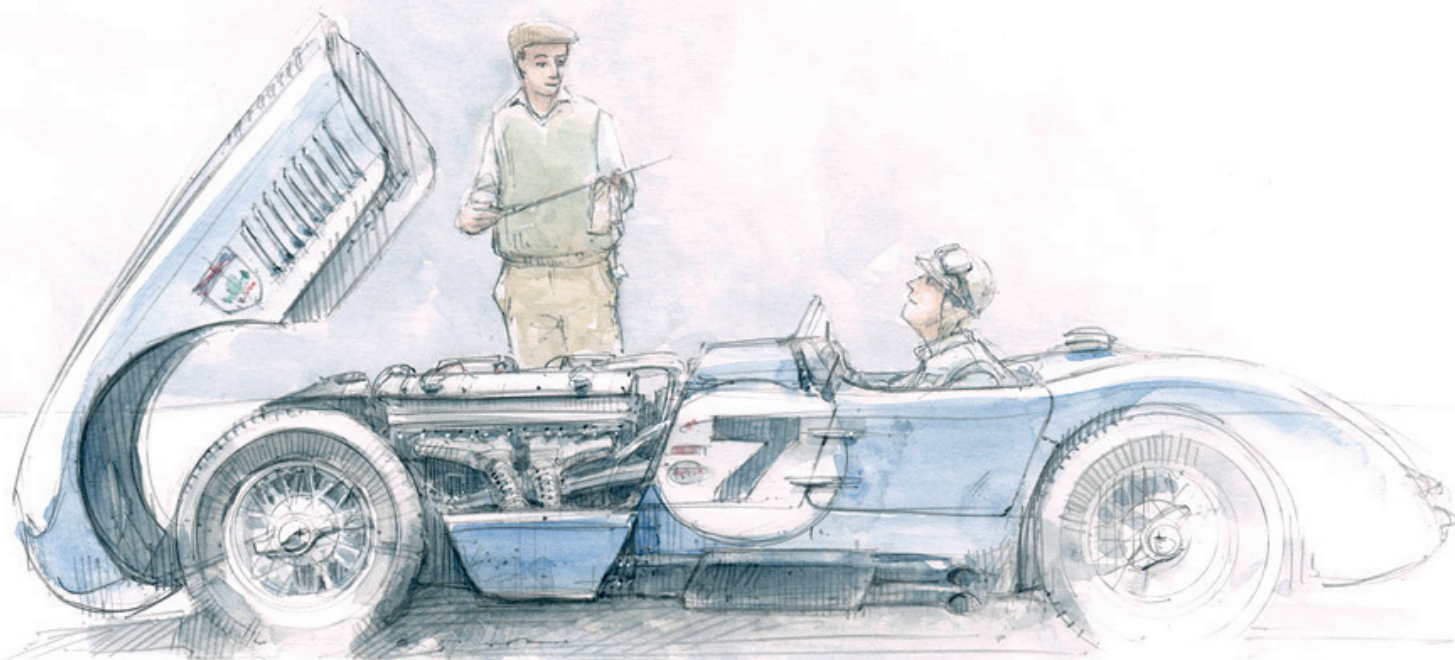

Dynolite oil produces high performance lubricants and additives specifically created for classic, vintage and veteran vehicles. Blended using high quality base oils combined with additives specially selected for their compatibility with metals and components used in the past, providing increased protection combined with a lower degree of acid and corrosion attack, less gumming and mud formation.

**moss-europe.co.uk**

Dynolite Stockist: Moss Europe Ltd



LONDON

## LONDON

Unit 16, Hampton Business Park, Bolney Way, Feltham  
**TW13 6DB**

London Tel

**+44 (0) 20 8867 2020**

E-mail

**sales@moss-europe.co.uk**

Fax

**+44 (0) 20 8867 2030**



BRADFORD

## BRADFORD

Unit 12-13, Acorn Park Ind. Est. Otley Road, Shipley  
**BD17 7SW**

Bradford Tel

**+44 (0) 1274 539 999**

E-mail

**bradford@moss-europe.co.uk**

Fax

**+44 (0) 1274 539 990**



BRISTOL

## BRISTOL

Unit 14 Avonside Ind. Park Avonside Road, Bristol  
**BS2 0UQ**

Bristol Tel

**+44 (0) 117 923 2523**

E-mail

**bristol@moss-europe.co.uk**

Fax

**+44 (0) 117 300 9164**



MANCHESTER

## MANCHESTER

111-117, Stockport Road Stockport, Cheshire  
**SK3 0JE**

Manchester Tel

**+44 (0) 161 480 6402**

E-mail

**manchester@moss-europe.co.uk**

Fax

**+44 (0) 161 429 0349**



PARIS MOTOR DREAM

## PARIS

7 rue Chaponval  
ZAC du Cornouiller  
78870 Bailly, France

Paris Tel

**+33 (0) 1 30 80 20 30**

E-mail

**sales@moss-europe.fr**

Moss Website  
[moss-europe.co.uk](http://moss-europe.co.uk)

Moss Paris Website  
[moss-europe.fr](http://moss-europe.fr)

Facebook  
[facebook.com/mosseurope](https://facebook.com/mosseurope)

Twitter  
[twitter.com/mosseurope](https://twitter.com/mosseurope)

Instagram  
[instagram.com/mosseuropeltd](https://instagram.com/mosseuropeltd)

Printed in the UK