

ISSUE 2

PARTS & ACCESSORIES FOR YOUR

MX-5

Restore • Maintain • Modify

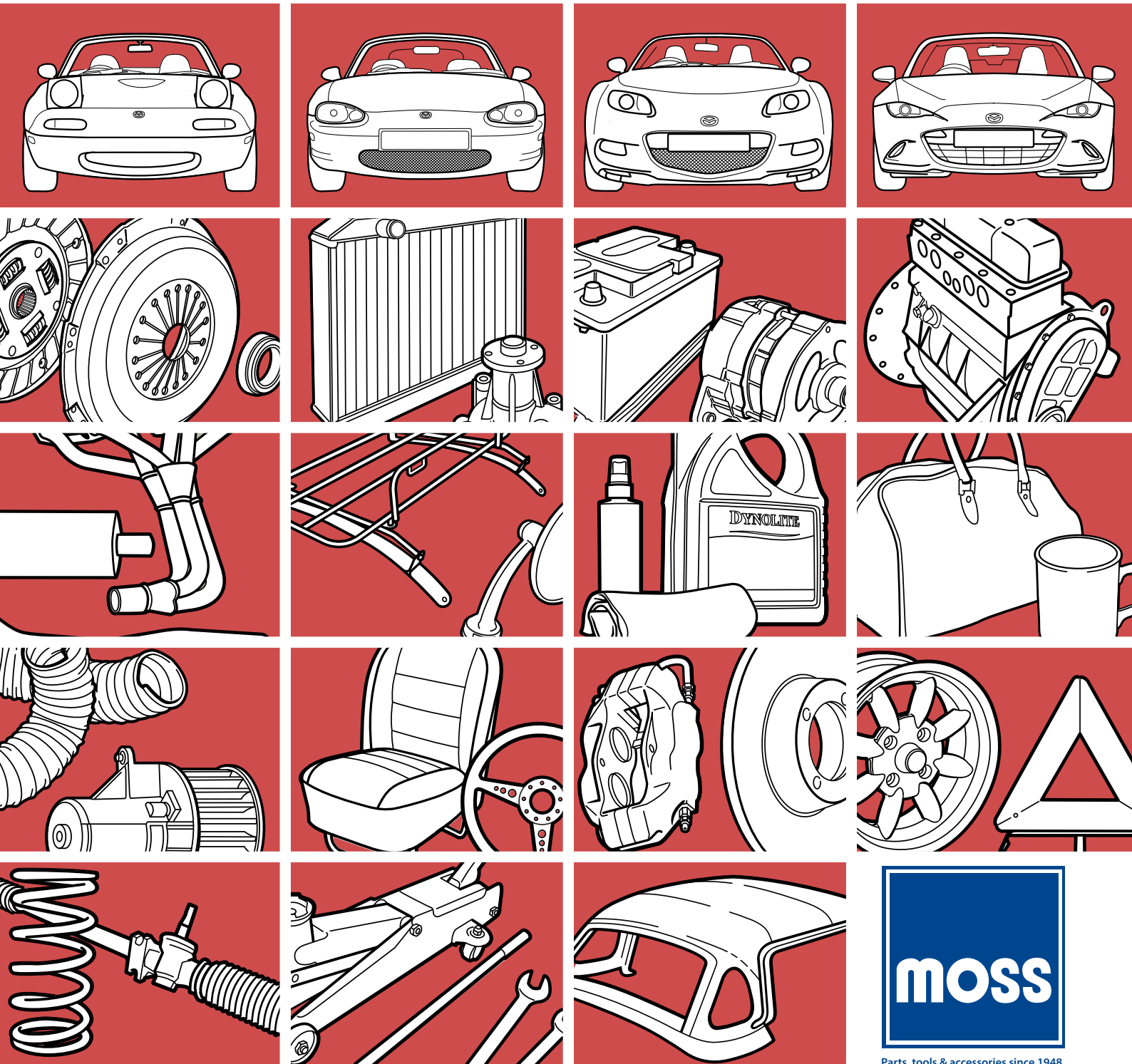

Parts, tools & accessories since 1948.

MAZDA MX-5 · MIATA · EUNOS · ROADSTER

Welcome to the Moss Europe MX-5 parts catalogue, containing our vast selection of parts and accessories from incredible brands such as Cobalt, Jackson Racing, Tourist Trophy, Mishimoto, EBC, SuperPro, Exedy, Garage Star, and Jass Performance. Our aim is to help you, not only look after your Mazda, but to also help you fulfil your vision for it, whether you are looking for performance, customisation or factory original parts.

Moss began supplying sports car parts in 1948, we now benefit from decades of experience and are one of the world's oldest and largest sports car parts and accessories specialists. Today, our mission is to supply parts and accessories of the highest standard. We offer friendly, professional and knowledgeable service and hold a vast number of parts in stock, available from our branches or online backed by fast, reliable worldwide delivery.

As well as the MX-5, we specialise in parts for Austin-Healey, Classic Mini, Jaguar, MG, Morris and Triumph.

Please check online at moss-europe.co.uk for up to date pricing and availability.

MOSS UK OPENING TIMES*

Open Monday to Friday 8.30am to 5.30pm

Saturday 9.00am to 1.00pm

*Opening times may vary.

Please call your nearest branch for more information.

See website for Paris opening times.



Keep up to date on all MX-5 news by following us on:

twitter.com/mosseurope

facebook.com/mosseurope

instagram.com/mosseuropeltd



DAVEFAB MOROSO



TRACK DOG
RACING



Techna
fit
Fluid Transfer
Systems



COBALT
PRECISION AUTOMOTIVE

DDMWorks



dba
DISC BRAKES AUSTRALIA

ACT
ADVANCED CLUTCH TECHNOLOGY



HAWK
PERFORMANCE



MAZDASPEED



GarageStar

MISHIMOTO

EBC
BRAKES



JASS
PERFORMANCE

Fidanza
flywheel specializes

EXEDY
RACING CLUTCH

Craven
Speed

CONTENTS

Aerials 37

- Stubby aerial
 - Short rake aerial
 - Replacement rubber aerial
- (Also see page 39)

Audio 21

- RetroSound radios
- Faceplates and knob kits
- Subwoofer

Brakes 8-9

- EBC brakes GreenStuff
- EBC brakes YellowStuff
- EBC brakes RedStuff
- EBC brakes Ultimate/BlackStuff
- Hawk brake pads
- DBA brake discs
- Goodridge brake hoses

Car protection 20

- Cobalt skid plates
 - Hardtop brackets
 - Boss Frog frame rail protectors
- (Also see page 31)

Cooling system 10

- Mishimoto radiators
- Mishimoto twin fans
- Moroso coolant tank
- I.L. Motorsport coolant tank
- Tourist Trophy radiator slam panel
- Track Dog Racing radiator slam panel

Engine components 19

- Fidanza cam gears
- Moroso oil catch can

Engine upgrades 38

- Oil filters
 - Oil filter adapter
- (See page 16 for oil filter tool)

Exterior styling 22-23

- Splitters from Track Dog Racing
- Touge Run lip spoilers
- R Speed lip spoilers
- Project M boot spoilers
- Turn signal intake
- Mirrors
- Overfenders

Fuel system and accessories 32

- Fuel cap
- Jackson Racing fuel pump
- DDM Works gauge holders
- Track Dog Racing gauge holders

GarageStar product range 31

- Delrin diff mounts
- Carbon fibre slam panel
- Carbon fibre spark plug cover
- Wing braces
- Skid plate for sump
- Front tow hook version 3.0
- Rear tow hook chassis mount
- Steering rack risers

Ignition system 7

- Cobalt HT lead set
 - Jackson Racing HT lead set
 - NGK spark plug
 - I.L. Motorsport spark plug cover
- (See page 31 for more spark plug covers)

Induction kits & filters 6

- Jackson Racing air intake kit
- Cobalt cold air intake
- DAVEFAB cold air intake kit
- DAVEFAB chasis jacking bar
- DAVEFAB washer bottle relocation kit

Interior upgrades 33-35

- Engine start buttons
- Chrome vent rings
- Delrin window bushings
- Door trim panels
- Deluxe carpet sets
- Rosewood gear knob & handbrake sleeve
- Sun visor blanks
- Cup holder
- Voodoo gear knobs
- Armrest pad
- Arm-restler

(Also see page 16 & 39)

Jazz performance range 14-17

- Offset number plate brackets
- Eng fuse box lid
- Turn signal intake
- Dip stick handle
- Engine hooks
- Servo/brake stopper
- Sun visor blanks with lights
- Gear stick extenders
- Frame rails
- Low pro lights
- Door pulls
- Drift button
- Tombstone cover
- Radio surround
- Cup holder
- Cup holder & window switches
- Ashtray surround
- Ashtray surround & window switches
- Electric window switches retro
- Scuttle panel
- Tow hooks
- Oil filter tool
- Instrument cluster

Light units, bulbs & accessories 13

- Light units
- Bulbs
- Reflectors
- Wing repeaters
- Brake pulser

(Also see page 14)

ND products 39

- Number plate relocation
- Delrin door bushes
- Single exit silencer
- Eye ball vents
- Factory boot liner
- H & R lowering springs
- Voodoo gear knobs
- Stubby aerial
- Adjustable anti roll bar links

Number plates 37

- Aftermarket number plate kits
 - Number plate plinth
- (Also see page 14 & 39)

OE badges 24

Oil cap 11

- I.L. Motorsport chrome oil cap

Pedal sets 11

- Pedal rubbers
- Cobalt pedal sets

Exhausts 4-5

- Cobalt silencers
 - Cobalt manifold
 - Cobalt mid-pipe
 - Track Dog blanket & exhaust wrap
 - RoadsterSport manifolds
 - RoadsterSport mid-pipes
 - Jackson Racing manifolds
 - Hondadata uprated gaskets
- (Also see page 39)

Rod's workshop manual 12

Stock replacement parts 40-42

- Gaskets/seals
- Belts
- Filters
- Cooling
- Running gear
- Outer panels
- Brakes
- Rubber
- Electrical
- Engine undertray

Strut braces from Cobalt 28-29

- Rear boot brace
- Engine strut brace 3 point
- Seatbelt tower brace
- Engine strut brace 3 point
- Front lower & rear lower braces
- PPF power kit

Style bars & windblocker 12

Suspension bracing & components 26-29

- Spax lowering springs
 - Jackson Racing anti roll bars
 - Cobalt anti roll bars
 - Cobalt anti roll bar links
 - Racing Beat anti roll bar links
 - Strut braces from I.L. Motorsport
- (Also see page 39)

Tin parking signs 12

Tow hooks 11

- Mazdaspeed tow hooks
 - Tow hooks
- (Also see page 16)

Transmission 18-19

- Performance clutches
- Stock clutch kits
- Lightened flywheels
- Clutch hoses/pipes
- Cobalt short shifter
- Shifter rebuild kits & spares

Travelling equipment 24-25

- Bicycle rack
- Boot racks
- Deck bags
- Heated blanket
- Cool Breeze scoop
- Cargo net
- Boot pocket pod

Polyurethane bushes, Engine mounts, Bump stop & cover 30

- Superpro bush sets & bushes
- Mazdaspeed engine mounts
- Bump stop & cover

Weather protection 36

- Car covers
- Hardtop caddy
- Hardtop hoists



910-620



900-494



900-492



WPE1104X



900-565



909-695



909-680

COBALT SILENCERS

Treat your MX-5 to one of the finest exhausts available exclusively from Moss. These beautifully finished mirror polished exhausts are packed with features usually only found on more expensive systems.

- ▶ 1.2mm thick 304 stainless steel used for silencer shell, tips, and piping
- ▶ Silencer packing is a combination of stainless steel wool and fibreglass for a perfect sportscar sound that is never intrusive
- ▶ CNC cut stainless steel flanges
- ▶ 409 stainless steel used for inner core and perforated tubing
- ▶ 60mm pipe diameter
- ▶ Beautifully shaped oval silencer
- ▶ All welds on silencer are ground smooth and polished
- ▶ Entire silencer completely polished to a mirror shine
- ▶ Polished tail pipe
- ▶ 5 year warranty

PRODUCT	MODEL	PART NO	PRICE
Single exit stainless steel cat-back (Fits cars with 375 or 440mm cat only)	90-97	900-494	£220.00
Dual exit stainless steel cat-back (Will only fit with 375 or 440mm cat)	90-97	900-492	£240.00
Single exit stainless steel silencer	98-05	900-565	£185.00
Dual exit stainless steel silencer	98-05	909-680	£265.00
Dual exit stainless steel silencer (Will not fit with appearance package)	05-15	909-695	£275.00
Blanking plug (May be required on 900-494 or 900-492)	90-97	WPE1104X	£4.24
Twin exit stainless steel silencer	16-18	910-620	£310.00

Visit moss-europe.co.uk for latest prices



TRACK DOG
RACING

MANIFOLD HEAT SHIELD

The exhaust manifold is the main source of heat under your MX-5's bonnet. By covering and isolating it with a Track Dog heat shield you will prolong the life of rubber engine parts. In addition, air entering your engine will be cooler allowing for maximum power to be generated from your MX-5. Can be fitted to all factory and aftermarket manifolds.

PRODUCT	MODEL	PART NO	PRICE
Manifold blanket/heat shield	All	971-450	£126.00



ROADSTERSPORT MANIFOLD

All T304 stainless steel construction throughout, RoadsterSport's 4 into 1 design delivers maximum power gains from the midrange through redline. The precision cut stainless steel engine-to-manifold flange transitions smoothly to primary tubing that collects into the 2.5" OD secondary. Exhaust gas exits the manifold through a specially designed stainless steel rear flange which mates to the factory mid-pipe, or the RoadsterSport 2.5" mid-pipe for maximum horsepower gains. The primary factory catalytic converter is deleted with this header. Lifetime warranty on this manifold.

PRODUCT	MODEL	PART NO	PRICE
Stainless steel manifold	05-15 2.0	904-935	£510.00



ROADSTERSPORT MID-PIPE

A stainless steel mid-pipe that adds horsepower and torque and will last a long time. RoadsterSport's offerings fit with all factory Manifolds and aftermarket systems, included are high flow catalytic converters and are 2.5" in diameter for the entire length. Both are slightly louder than stock. Warranty: 5 year/50,000 mile manufacturing defect warranty on the housing and 25,000 mile manufacturing defect warranty on the internals.

PRODUCT	MODEL	PART NO	PRICE
Roadstersport performance mid-pipe	05-15	904-691	£479.40



903-110

903-120

JACKSON RACING

JACKSON RACING MANIFOLDS

The Jackson Racing manifold pulls hard through a wide power-band without that head-throbbing resonance often found in low-quality manifolds. Features include heavy gauge steel, mandrel bent tubes, CNC-machined flanges and ceramic coating. The result is a TIG-welded manifold that provides maximum performance, total precision and lifelong durability.

PRODUCT	MODEL	PART NO	PRICE
4-2-1 Sports manifold (Fits manual transmission only)	89-93 1.6	903-110	£426.60
4-2-1 Sports manifold (Fits manual transmission only)	94-97 1.8	903-120	£426.60



903-991



903-992

UPDATED GASKETS

HONDATA

Hondata has developed a special high temperature insulating gasket which replaces the stock intake gasket. The MX-5 manifold is heated in up to 5 places. From the cylinder head, the cold idle valve, the idle control valve and the throttle body heater. Hondata's new gasket coupled with bypassing several heat sources significantly reduces the transfer of heat from the cylinder head to the intake manifold and incoming air giving you up to 5% more power.

PRODUCT	MODEL	PART NO	PRICE
Updated inlet manifold gasket	89-93 1.6	903-990	£50.80
Updated inlet manifold gasket	94-97 1.8	903-991	£50.80
Updated inlet manifold gasket	98-05 1.8	903-992	£50.80



COBALT
PRECISION AUTOMOTIVE

COBALT MID-PIPE

Full stainless steel 2.5" pipes and welded-in 48-state catalytic converter, this bolts to factory or Cobalt manifolds and silencers. Factory location O2 connection. Includes magnaflow catalyst converter.

Please note: This is a direct fit for 1998-99 MX-5 models. To fit 2000-05 MX-5's a performance manifold will need to be installed.

PRODUCT	MODEL	PART NO	PRICE
Cobalt performance mid-pipe	98-05	909-960	£300.00

89-97 NA Mk1 | 98-05 NB Mk2/2.5 | 05-15 NC Mk 3/3.5/3.75 | 16> ND Mk4

LONDON 020 8867 2020

BRADFORD 01274 539 999

BRISTOL 0117 923 2523

MANCHESTER 0161 480 6402

PARIS 01 30 80 20 30



MXV1176X

JACKSON RACING AIR INTAKE KIT

The Jackson Racing Cold Air Intake allows your car to breath clean, cool air for maximum horsepower, up to 14HP in most cases. If you are old enough to remember the old muscle cars with Cowl-Air Induction and Ram-Air Induction, you know that cold air does help performance. Instead of adding one of those unsightly hoods that you can barely see over, the JR Cold Air Induction system tucks neatly under the bonnet. A strategically placed scoop brings cold air into the throttle body with increased velocity. The combination of cool air and pressurised air (at speed) will increase your horsepower. Each system includes a high-velocity air filter for increased airflow and filtration.

PRODUCT	MODEL	PART NO	PRICE
Cold air intake	89-93 1.6	MXV1176X	£332.00
Replacement filter	89-97	901-987	£33.65
Upated panel filter (fits factory air box)	89-05	901-975	£28.04



909-605

COBALT COLD AIR INTAKE

Clean up the front of your engine; add a nice growl sound on acceleration, and a little more power too with this Air Intake System by Cobalt. Designed with a shield to keep intake air cool and protected from hot ambient engine temperatures, also features a reusable K&N brand filter. The arm is rotomolded and textured black plastic, and the heat shield is black painted steel. Includes all installation hardware and instructions.

PRODUCT	MODEL	PART NO	PRICE
Cold air intake	98-05	909-605	£160.00
Cold air intake	05-15	904-377	£51.00

DAVE FAB

INNOVATION • DESIGN • FABRICATION

DAVE FAB

Located close to the famous Castle Combe race circuit in the UK, DaveFab have made a name for themselves in the MX-5 community by designing and fabricating some of the most innovative and bespoke modifications for the MX-5 in a long time, and with such an iconic race track nearby you can be assured they have been tested to the limit and passed DaveFab's strenuous testing procedures.

PRODUCT	MODEL	PART NO	PRICE
Cold air intake kits	89-97 1.6	MXV155010	£289.98
Cold air intake kits	89-97 1.8	MXV155011	£289.98

PRODUCT	MODEL	PART NO	PRICE
Chassis Jacking Bars	89-97	MXV155110	£140.00
Chassis Jacking Bars	98-05	MXV155111	£140.00

PRODUCT	MODEL	PART NO	PRICE
Washer Bottle Relocation Kits	89-05 RHD	MXV155210	£140.00
Washer Bottle Relocation Kits	89-05 LHD	MXV155211	£140.00



MXV155010



MXV155110



MXV155210

Visit moss-europe.co.uk for latest prices



JACKSON RACING AND COBALT HT LEAD SETS

Cobalt Ignition Wire Sets are made precisely for your vehicle, and carry a Lifetime Warranty against defective materials or workmanship! The Cobalt wires feature:

- ▶ **Compact silicone plug boots** provide extra clearance
- ▶ **EPDM layer** provides more electrical insulation than silicone-over-silicone
- ▶ **Conductive polymer coating** protects the conductor and provides terminal contact
- ▶ **Stainless steel conductor** for maximum conductivity
- ▶ **Aramid fibers** provide superior tensile strength
- ▶ **Spiral magnetic core** suppresses RFI/EMI interference
- ▶ **Fiberglass braid** provides superior tensile strength
- ▶ **8mm silicone jacket** resists high temperatures, fuels and oils
- ▶ **Locking terminals** stay connected under high vibration

PRODUCT	MODEL	PART NO	PRICE
Cobalt HT lead set (Set of four)	89-00	971-108	£30.60
Cobalt HT lead set (Set of two)	01-05	971-109	£20.40
JR HT lead set (set of four)	89-00	971-510	£30.60



BKR7EIX-11 BKR5E-11 971-116 BKR6E-11 BKR6EVX-11

SPARK PLUGS FROM NGK



Not all spark plugs are created equal!

NGK plugs are constructed for longer life and optimum performance. Pick up an extra set for your toolbox. Plugs should arrive pre-gapped although it never hurts to double check! (Sold individually).

PRODUCT	MODEL	PART NO	PRICE
NGK spark plug (sold individually)	89-93, 1.6 Supercharged	BKR7EIX-11	£11.10
NGK spark plug (sold individually)	94-97, 1.8	BKR5E-11	£2.86
NGK spark plug (sold individually)	94-05, 1.8 Iridium	971-116	£11.35
NGK spark plug (sold individually)	89-39, 1.6	BKR6E-11	£2.86
NGK spark plug (sold individually)	89-93, 1.6 Platinum	BKR6EVX-11	£11.35



89-97 NA Mk1 | 98-05 NB Mk2/2.5 | 05-15 NC Mk 3/3.5/3.75 | 16> ND Mk4

LONDON 020 8867 2020

BRADFORD 01274 539 999

BRISTOL 0117 923 2523

MANCHESTER 0161 480 6402

PARIS 01 30 80 20 30

HAWK BRAKE PADS

Hawk brake pads are manufactured using the highest quality materials available for Street-performance driving. For the serious performance driver, this is the best brake pad we offer.

Hawk Performance's HP Plus brake pad compound is ideal for Autocross and Track Day drivers looking for a high performance race compound that can take the heat of the track and get you home safely without having to change the pads. HP Plus utilizes a unique Ferro-Carbon, high-tech friction material that was developed and manufactured for sport driving in autocross, Solo II and "track day" applications. The Ferro-Carbon formulation offers lower wear rates and higher torque values than other competitive materials. Extremely high coefficient of friction makes HP Plus the perfect upgrade over stock for high performance streetcars used in autocross competition or that experience repetitive, heavy braking.

PRODUCT	MODEL	PART NO	PRICE
Front brake pads	Fits all MK1 1.6	901-550	£121.00
Rear brake pads	Fits all MK1 1.6	901-555	£121.00
Front brake pads	Fits all MK1 1.8 and MK2/2.5 1.6 models and 1.8 standard brake models 1998>2005 with a disc diameter of 255mm	901-560	£124.00
Rear brake pads	Fits all MK1 1.8 and Mk2/2.5 1.6 models and 1.8 standard brake models 1998>2005 with external disc diameter of 251mm	901-565	£121.00



EBC BRAKES GREENSTUFF



EBC's latest formulation for use on fast street or light duty race use. Good bite from cold and effective to 550°C. Almost complete elimination of brake dust and the improved thermal conductivity prevents disc warping. Asbestos free.

PRODUCT	MODEL	PART NO	PRICE
Front brake pads	Fits all Mk1 1.6 models	MXV1270G	£60.00
Rear brake pads	Fits all Mk1 1.6 models	MXV1271G	£50.70
Front brake pads	Fits all Mk1 1.8 models	MXV1272G	£67.30
Rear brake pads	Fits all Mk1 1.8 models	MXV1273G	£59.00
Front brake pads	Fits all Mazda MX-5 Mk2/2.5 1.6 models and 1.8 standard brake models 1998>2005 with external disc diameter of 255mm	MXV1272G	£67.30
Rear brake pads	Fits all Mazda MX-5 Mk2/2.5 1.6 models and 1.8 standard brake models 1998>2005 with external disc diameter of 251mm	MXV1273G	£59.00
Front brake pads	Fits all Mazda MX-5 Mk2/2.5 1.8 and 1.8is big brake models 1998>2005 with external disc diameter of 270mm	MX51272G	£66.20
Rear brake pads	Fits all Mazda MX-5 Mk2/2.5 1.8 and 1.8is big brake models 1998>2005 with external disc diameter of 276mm	MX51273G	£49.70
Front brakes pads	Fits all Mazda MX-5 05-15 without big brake upgrade	MXV1274G	£72.50
Rear brakes pads	Fits all Mazda MX-5 05-15 without big brake upgrade	MXV1275G	£67.30



901-550



901-565



MXV1274Y

MXV1275Y

EBC BRAKES YELLOWSTUFF



Although a full race material and capable of high temperature use with very good wear life, the YellowStuff formulation sets a new trend in race type brake pad compounds. The "bite" from cold is superb which is uncommon with race materials (normally requiring warm-up) and makes this a pad which can be safely used on the road as well as on the race track.

PRODUCT	MODEL	PART NO	PRICE
Front Brake pads	Fits all Mk1 1.6 models, 1989>1998	MXV1270Y	£84.90
Rear Brake pads	Fits all Mk1 1.6 models, 1989>1998	MXV1271Y	£82.90
Front Brake pads	Fits all Mk1 1.8 models, 1993>1998	MXV1272Y	£102.50
Rear Brake pads	Fits all Mk1 1.8 models, 1993>1998	MXV1273Y	£80.70
Front Brake pads	Fits all Mazda MX-5 Mk2/2.5 1.6 models and 1.8 standard brake models 1998>2005 with external disc diameter of 255mm	MXV1272Y	£102.50
Rear Brake pads	Fits all Mazda MX-5 Mk2/2.5 1.6 models and 1.8 standard brake models 1998>2005 with external disc diameter of 251mm	MXV1273Y	£80.70
Front Brake pads	Fits all Mazda MX-5 Mk2/2.5 1.8 and 1.8is big brake models 1998>2005 with a disc diameter of 270mm	MX51272Y	£105.60
Rear Brake pads	Fits all Mazda MX-5 Mk2/2.5 1.8 and 1.8is big brake models 1998>2005 with a disc diameter of 276mm	MX51273Y	£86.90
Front Brakes pads	(Fits all Mazda MX-5 05-15 without big brake upgrade)	MXV1274Y	£150.10
Rear Brakes pads	Fits all Mazda MX-5 05-15 without big brake upgrade	MXV1275Y	£103.50

Visit moss-europe.co.uk for latest prices

EBC
BRAKES

MXV8136

EBC BRAKES ULTIMAX/BLACKSTUFF

Brake pads are a simple investment that can save you from costly repairs. EBC pads offer performance, without the need to build tremendous heat to make them work.

PRODUCT	MODEL	PART NO	PRICE
Front brake pads	Fits all Mk1 1.6 models, 1989>1998	MXV8138	£16.60
Rear brake pads	Fits all Mk1 1.6 models, 1989>1998	MXV8135	£22.80
Front brake pads	Fits all Mk1 1.8 models, 1993>1998	MXV8136	£24.80
Rear brake pads	Fits all Mk1 1.8 models, 1993>1998	MXV8137	£22.80
Front brake pads	Fits all Mazda MX-5 Mk2/2.5 1.6 models and 1.8 standard brake models 1998>2005 with a disc diameter of 255mm	MXV8136	24.80



MXV1270R

MXV1275R

EBC
BRAKES

EBC BRAKES REDSTUFF

Redstuff pads are better suited for fast road driving and cars that are above 200bhp. RedStuff is a truly impressive fast road pad for repeated heavy braking. It emits far less dust than semi-metallic pads, and features EBC Brake-In™ surface coating which conditions the rotor surface and accelerates pad bed-in.

PRODUCT	MODEL	PART NO	PRICE
Front Brake pads	Fits all Mk1 1.6 models, 1989>1998	MXV1270R	£70.40
Rear Brake pads	Fits all Mk1 1.6 models, 1989>1998	MXV1271R	£67.30
Front Brake pads	Fits all Mk1 1.8 models, 1993>1998	MXV1272R	£83.80
Rear Brake pads	Fits all Mk1 1.8 models, 1993>1998	MXV1273R	£67.30
Front Brake pads	Fits all Mazda MX-5 Mk2/2.5 1.6 models and 1.8 standard brake models 1998>2005 with external disc diameter of 255mm	MXV1272R	£83.80
Rear Brake pads	Fits all Mazda MX-5 Mk2/2.5 1.6 models and 1.8 standard brake models 1998>2005 with external disc diameter of 251mm	MXV1273R	£67.30
Front Brake pads	Fits all Mazda MX-5 Mk2/2.5 1.8 and 1.8is big brake models 1998>2005 with external disc diameter of 270mm	MX51272R	£83.80
Rear Brake pads	Fits all Mazda MX-5 Mk2/2.5 1.8 and 1.8is big brake models 1998>2005 with external disc diameter of 276mm	MX51273R	£65.20
Front Brakes pads	(Fits all Mazda MX-5 05-15 without big brake upgrade)	MXV1274R	£99.40
Rear Brakes pads	Fits all Mazda MX-5 05-15 without big brake upgrade	MXV1275R	£83.80



901-050

dba
DISC BRAKES AUSTRALIA

DBA BRAKE DISCS

Get the stopping power you need. Cross-drilled holes lower brake temperatures and reduce rotational mass and out-gassing, while slots allow excess water, dirt and dust to dissipate. Simply the best disc we offer. Sold as a pair.

PRODUCT	MODEL	PART NO	PRICE
Front brake disc	Fits all MK1 1.6	901-050	£144.96
Rear brake disc	Fits all MK1 1.6	901-055	£125.04
Front brake disc	Fits all MK1 1.8 and Mk2/2.5 1.6 models and 1.8 standard brake models 1998>2005 with external disc diameter of 255mm	901-060	£144.96
Rear brake disc	Fits all MK1 1.8 and Mk2/2.5 1.6 models and 1.8 standard brake models 1998>2005 with external disc diameter of 251mm	901-065	£144.96
Front brake disc	Fits all MK2.5 with factory big brake option	901-070	£183.60
Rear brake disc	Fits all MK2.5 with factory big brake option	901-075	£142.80

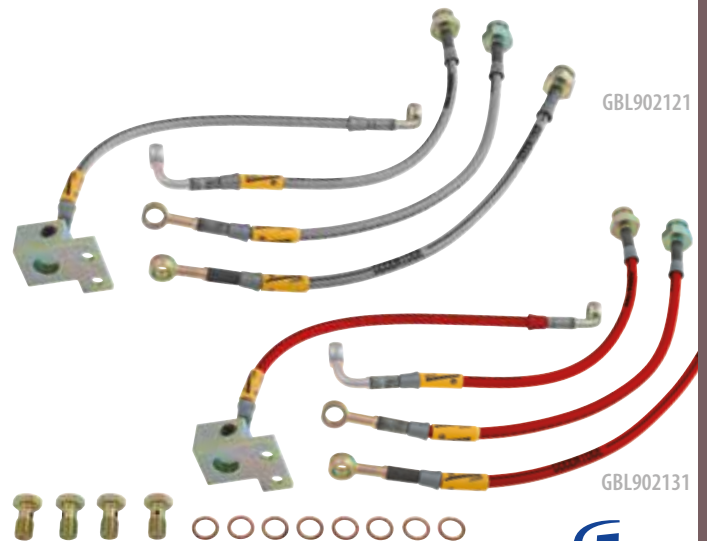

GBL902121

GBL902131

GOODRIDGE BRAKE HOSES

GOODRIDGE

Our high performance stainless braided brake lines eliminate the mushy pedal feel you get when your OEM rubber lines expand. Utilizing Teflon tubing with a stainless steel outer tube, this 4-line set is DOT-approved, and works perfectly on the track or on the street. Includes all necessary mounting hardware. Sets available in silver or red.

PRODUCT	COLOUR	MODEL	PART NO	PRICE
Set of four hoses	Silver	89-05	GBL902121	£84.00
Set of four hoses	Red	89-05	GBL902131	£84.00
Set of four hoses	Silver	05-16	GBL902123	£95.00
Set of four hoses	Red	05-16	GBL902133	£95.00

89-97 NA Mk1 | 98-05 NB Mk2/2.5 | 05-15 NC Mk 3/3.5/3.75 | 16> ND Mk4

LONDON 020 8867 2020

BRADFORD 01274 539 999

BRISTOL 0117 923 2523

MANCHESTER 0161 480 6402

PARIS 01 30 80 20 30



MISHIMOTO RADIATORS

Mishimoto brings the MX-5 community parts designed from the racing environment, smartly engineered for easy installation with no modifications. All-aluminium construction radiators have no plastic parts to fail (OEM radiators do). Fits manual transmission only.

- ▶ All pieces designed to fit stock locations
- ▶ No modifications to fit
- ▶ All radiators come with new cap
- ▶ Limited lifetime warranty

PRODUCT	MODEL	PART NO	PRICE
2 row radiator	89-97	909-560	£255.00
3 row radiator	90-97	909-561	£311.10
2 row radiator	98-05	909-562	£244.80



MISHIMOTO TWIN FANS

The Mishimoto Mazda MX-5 fan shroud kit will considerably improve engine cooling functions and the overall performance of your vehicle. All Mishimoto fan shrouds are significantly lighter than standard fan shrouds, and fit the Mishimoto aftermarket radiator. A Mishimoto fan shroud will effectively drive out heat from the engine bay and deliver a significant amount of cooler air directly to your new Mishimoto radiator. At the same time the fan shroud serves another very important purpose: securing the fan blades. The fan shroud will keep the fan blades in place, which otherwise could potentially damage other essential components in your engine. Includes fans and motors.

PRODUCT	MODEL	PART NO	PRICE
Twin fan kit	89-97	909-565	£181.00
Twin fan kit	98-05	909-566	£181.00



MOROSO COOLANT TANK

Moroso aluminium tanks don't just look good, they have been engineered for performance! aluminium is stronger and lighter weight than the factory plastic reservoirs. Performance features have been built into these tanks while retaining stock characteristics where necessary, Comes with a Moroso logo cap.

PRODUCT	MODEL	PART NO	PRICE
Aluminium coolant tank (Supplied with cap)	89-97	909-250	£193.80



I.L. MOTORSPORT COOLANT TANK

Add a performance look under the hood of your MX-5 with this highly polished aluminium coolant overflow tank from I.L. Motorsport. Features an exterior clear level indicator so you can easily check your coolant level, and ventilation provided by a polished aluminium breather tube on the outside of the tank. Installs in the OEM factory location.

PRODUCT	MODEL	PART NO	PRICE
Aluminium coolant tank (Supplied with cap)	89-97	909-546	£175.40



902-497

902-498

TOURIST TROPHY RADIATOR SLAM PANEL

Precision cut from polished stainless steel, this radiator cowl cover really dresses up your engine bay. It also closes off an area where some air can escape over the top of your radiator, instead of going straight through. Adds a bit of cooling efficiency and a great look! Supplied with fittings.

PRODUCT	MODEL	PART NO	PRICE
Polished slam panel	89-97	902-497	£25.50
Polished slam panel	98-05	902-498	£25.50



TRACK DOG RACING RADIATOR SLAM PANEL

Increase your cooling efficiency and dress up your MX-5. The TDR radiator cowl covers the area between the bumper and the radiator forcing incoming air through your radiator instead of letting it escape over the top. All aluminium construction with a black wrinkle powder-coated finish and accented with an engraved Track Dog Racing badge.

PRODUCT	MODEL	PART NO	PRICE
Black slam panel	89-97	904-710	£65.30

909-245



I.L. MOTORSPORT 710 OIL CAP

Not merely a cover that you need to glue to your stock oil cap, this is a complete chrome replacement. Spoil your MX-5 with a little jewellery under the hood, with this quality piece that will keep its beauty for a long time.

PRODUCT	MODEL	PART NO	PRICE
Chrome oil cap	89-97	909-245	£46.00

MAZDASPEED



903-985

MAZDASPEED TOW HOOKS

Specifically designed to bolt right up to existing holes, these Tow Hooks are SCCA legal for racing applications. These are the hooks the track officials use to clip the tow line to your MX-5, to get it off the track if it's disabled.

PRODUCT	MODEL	PART NO	PRICE
Mazdaspeed tow hooks	89-97	903-985	£66.30



909-280



909-281

TOW HOOKS

If you're building a Spec MX-5 for racing, these are required. Or, throw a pair on the street MX-5 you occasionally take to the track. Either way, these are what the officials use to hook your car to the tow line to haul your MX-5 off the track if it's disabled. One front and one rear hook. '99 MX-5's will need one hole drilled, instructions included. Sold as a pair.

PRODUCT	MODEL	PART NO	PRICE
Tow hooks red	98-05	909-280	£39.35
Tow hooks silver	98-05	909-281	£39.35



998-201

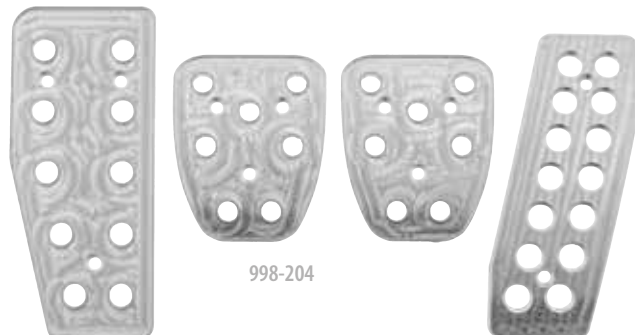

998-204



COBALT
PRECISION AUTOMOTIVE

COBALT PEDAL SETS

Your feet are an integral part of the MX-5 driving experience. From the factory, your MX-5's control pedals are meant to work with a wide variety of driving tastes. Cobalt's billet pedal system is the ultimate for those of you who want to feel one with the road. Made specifically for the MX-5 and machined from aircraft quality aluminium, you will enjoy improved feel of the controls and outstanding grip. More experienced drivers will appreciate the ability to "Heel & Toe". Set includes accelerator, brake, clutch and footrest pedals. Comes complete with instructions and easily installed using simple hand tools, may require drilling.

PRODUCT	MODEL	PART NO	PRICE
Cobalt pedal set (Roadster Logo, billet finish (Set of four))	89-97	998-201	£59.30
Cobalt pedal set (Roadster logo, billet finish (Set of four))	98-05	998-203	£59.30
Cobalt pedal set No logo, billet finish (Set of four)	89-97	998-204	£59.30
Cobalt pedal set (No logo, billet finish (Set of four))	98-05	998-205	£59.30



900-351

900-341

PEDAL RUBBERS

Keep your pedals from feeling greased-up when it rains. Our new pedal material helps prevent you from slipping even when your feet are wet. Roadster Logo (Manual Transmission only).

PRODUCT	MODEL	PART NO	PRICE
Rubber accelerator pad	89-05	900-351	£5.65
Rubber clutch/brake pad	89-05	900-341	£5.65

89-97 NA Mk1 | 98-05 NB Mk2/2.5 | 05-15 NC Mk 3/3.5/3.75 | 16> ND Mk4

LONDON 020 8867 2020 BRADFORD 01274 539 999 BRISTOL 0117 923 2523 MANCHESTER 0161 480 6402 PARIS 01 30 80 20 30



STYLE BARS

Another Moss exclusive! This new style bar by Cobalt is manufactured so that no cutting of your interior body panels is required! Additionally, seat travel and recline are not impeded in any way. Available in your choice of chrome or black painted. Easily installs in about 30 minutes with simple hand tools. Instructions included. Do not work with 99-05 factory wind blocker. On 94-97 MX-5's the factory seat tower brace must be removed.

Please note: These style bars are decorative items only and not intended for roll over protection.

PRODUCT	MODEL	PART NO	PRICE
Cobalt style bar chrome	89-05	903-305	£95.00
Cobalt style bar black	89-05	903-310	£110.00
Cobalt Windblocker (Fits cobalt style bar 903-305/903-310)	89-05	904-151	£163.20

METAL PARKING SIGNS

MX-5 territory should be posted! Hang these signs at home or at the office, wherever you park your MX-5.

COLOUR	MODEL	PART NO	PRICE
Red	89-97	215-800	£17.00
Blue	89-97	215-805	£17.00
Green	89-97	215-820	£17.00
Black	89-97	215-855	£17.00
Red	98-05	215-935	£17.00
Blue	98-05	215-950	£17.00
Green	98-05	215-96	£17.00
Silver	98-05	215-955	£17.00
Red	05-15	215-975	£17.00



ROD'S WORKSHOP MANUAL

By Rod Grainger. The super-manual for MX-5 owners. The author has personally dismantled and reassembled a MX-5, taking step-by-step pictures of all procedures. This, combined with his personal interest in the MX-5 and his years of writing and editing Haynes manuals, provides the background necessary to write the best MX-5 shop manual available. Coverage includes maintenance, repairs, modifications and improvements on all 1.8-liter MX-5's from 1994-97. Softbound, 368 pages.



MODEL	PART NO	PRICE
94-97 1.8	211-575	£35.00



GLU71311



MXV1227



GLB472

CIBIE HEADLAMPS

Cibie have been leaders in technological innovations for vehicle lighting for more than 80 years, and were the first choice for numerous motorsport teams. A must have on Mk1 MX5's as these offer unrivalled quality with an excellent beam pattern, improving visibility.

PRODUCT	MODEL	PART NO	PRICE
Headlamp unit RHD	89-97	GLU71311	£42.20
Headlamp unit LHD	89-97	GLU71312	£49.60



GAC4022X



162-890



GLB472BLU



GLB472X

REFLECTORS

Replace your factory reflectors with these stylish clear markers. Sold as a pair, not DOT approved.

PRODUCT	MODEL	PART NO	PRICE
Side marker/reflector kit clear (Two kits required per car)	89-05	162-890	£44.90



MXV1337



MXV1338



MXV1339

WING REPEATERS

Amazing quality smoked or clear side repeaters with chrome ring, supplied as a pair with two amber bulbs.

PRODUCT	MODEL	PART NO	PRICE
Clear wing repeaters (Pair)	89-05	MXV1337	£24.00
Smoked wing repeaters (Pair)	89-05	MXV1338	£24.80
Chrome wing repeater rings (Single)	89-05	MXV1339	£9.00

LIGHT UNITS

Are you fed up of your candle bright headlamps then why not upgrade to one of our Wipac conversions, replaceable H4 bulb. Sold in pairs and supplied with bulbs. Fancy an upgrade why not try some of our brighter bulbs.

PRODUCT	MODEL	PART NO	PRICE
Halogen headlamp kit (Pair of housings and bulbs)	89-97	MXV1227	£46.80
Crystal clear headlamp kit	89-97	GAC4022X	£58.90
Standard headlight bulb H4 (Single)	89-97	GLB472	£5.12
Headlight bulb blue H4 (Pair)	89-97	GLB472BLU	£10.40
Headlight bulb super white H4 (Pair)	89-97	GLB472X	£10.40

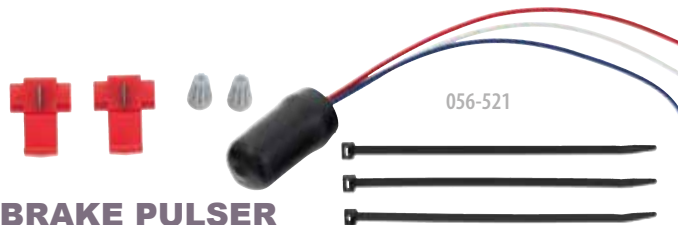

056-521

BRAKE PULSER

Enhance your safety by adding brake light pulsing to your third brake light. The brake light pulser module connects to your centre high mount brake light (third brake light) and automatically pulses it when you apply your brakes. The light will pulsate on and off for about a second, then stay on steady for as long as you press the brake pedal. Incorporated in the pulser is the "Delay-Repeat" circuit, which requires the brake lights to be off for at least 15 seconds before the cycle can be restarted. So, if you are in bumper-to-bumper traffic, the brake light isn't always pulsing.

PRODUCT	MODEL	PART NO	PRICE
3rd brake light pulser	All	056-521	NCA



Vlad graduated with a degree in mechanical engineering in Germany and worked as a concept engineer for BMW for years in Munich, with having a close overview of all aspects of car engineering his passion for cars and racing has got bigger and bigger. Vlad was participating with an MX-5 in racing events in Germany and AE86 in Bulgaria which then led to Jass performance being born.

Jass Performance was started in 2010, utilizing the resources of Jass Engineering, Vlad's founding company providing engineering solutions (construction, production) to the German automotive industry. The idea behind Jass Performance was to provide fellow enthusiasts the same opportunity to help develop their own projects, as people are having unique and good ideas Vlad took this on board and made these products. All parts that have been developed through the years were offered to everyone out there. True automotive functionality behind the products, Vlad gets a lot of his ideas from racing his roadster and thinking what could I design next to improve things or what I could I use to make that look better.

Vlad's enthusiasm for the little roadster has led to some of the best looking parts available on the market today, the more we all ask for the more he will design and continue to offer some amazing products.

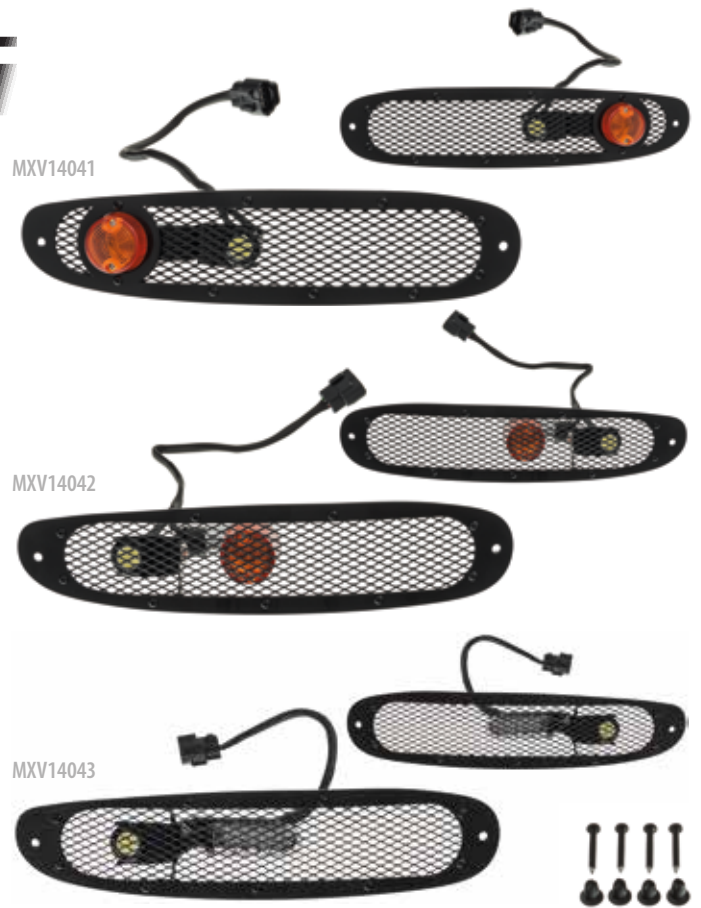

PRODUCT	MODEL	PART NO	PRICE
Classic TSIs	89-97	MXV14041	£152.00
Stealth TSIs	89-97	MXV14042	£152.00
Stealth TSIs L.E.D	89-97	MXV14043	£175.00

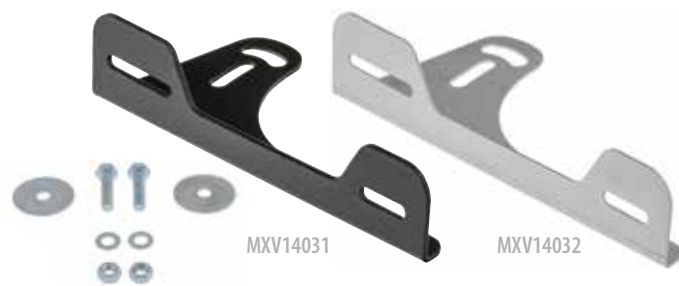

PRODUCT	MODEL	PART NO	PRICE
Offset n/plate bracket black	89-05	MXV14031	£31.40
Offset n/plate bracket polished	89-05	MXV14032	£31.40

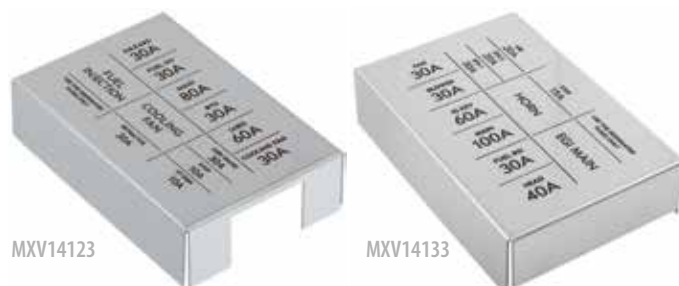

PRODUCT	MODEL	PART NO	PRICE
Engraved fuse box lid	89-97	MXV14123	£20.00
Engraved fuse box lid	98-05	MXV14133	£23.00



PRODUCT	MODEL	PART NO	PRICE
Dip stick handle	89-05	MXV14121	£24.00



PRODUCT	MODEL	PART NO	PRICE
Engine hook stainless steel rear	89-05	MXV14082	£25.00
Engine hook stainless steel front	89-05	MXV14081	£21.80



PRODUCT	MODEL	PART NO	PRICE
Servo/brake stopper/trurret mount	89-05	MXV14010	£53.00



SUN VISOR BLANKS WITH LIGHTS L.E.D

These Sun visor interior lights are a direct replacement for the stock sun visors. Using strong LED's they will light the interior and entrance area. All fitting hardware supplied.

PRODUCT	MODEL	PART NO	PRICE
Sun visor blanks with lights L.E.D	89-05	MXV14124	£65.60



PRODUCT	MODEL	PART NO	PRICE
Gear stick extender polished 1" (Fits manual cars only)	89-05	MXV14073	£23.00
Gear stick extender Red 2" (Fits manual cars only)	89-05	MXV14072	£23.00
Gear stick extender Black 1" (Fits manual cars only)	89-05	MXV14071	£23.00



FRAME RAILS

They stiffen the convertible body structure of the MX-5 offering rustproof under floor protection especially on lowered cars. They also provide strong points for jacking the car.

PRODUCT	MODEL	PART NO	PRICE
Stainless steel frame rails (2.9kg each)	89-05	MXV14061	£153.00
Stainless steel Frame rails Heavy duty	89-05	MXV14062	£178.00



PRODUCT	MODEL	PART NO	PRICE
Low pro lights	89-97	MXV14051	£380.00

PRODUCT	MODEL	PART NO	PRICE
Door pulls plain	89-97	MXV14227	£28.10
Door Pulls MX-5 logo	89-97	MXV14226	£30.20
Door pulls Roadster logo	89-97	MXV14225	£28.00
Door pulls vintage polished	89-97	MXV14228	£56.00

DRIFT BUTTON

A direct replacement for the stock version but with a twist, you can install for looks to match your handbrake sleeve and gearknob or when fitting remove the spring inside and install, you will loose the locking side of the handbrake but if your using your car for drifting events this is perfect.

PRODUCT	MODEL	PART NO	PRICE
Drift button	89-05	MXV14340	£16.60

JASS PERFORMANCE

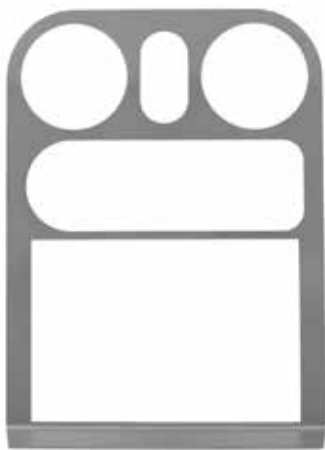

MXV14350



MXV14351

PRODUCT	MODEL	PART NO	PRICE
Tombstone cover, stainless steel	89-97	MXV14350	£60.30
Radio surround, stainless steel	98-05	MXV14351	£86.50



MXV14330

MXV14331

PRODUCT	MODEL	PART NO	PRICE
Cup holder keyhole style	89-97	MXV14330	£25.00
Cup holder and window switches	89-97	MXV14331	£37.30

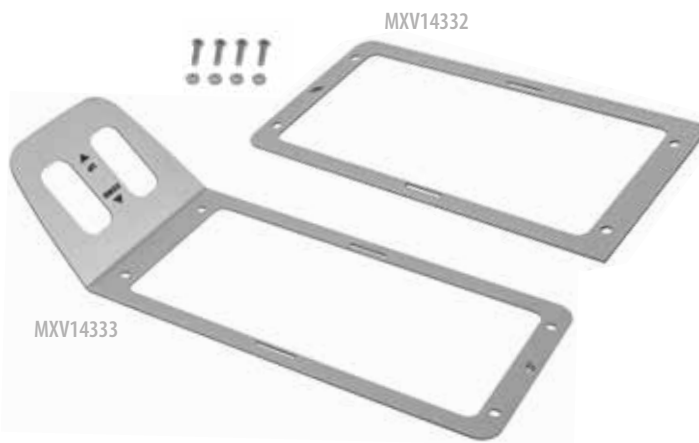

MXV14332

MXV14333

PRODUCT	MODEL	PART NO	PRICE
Ashtray surround, stainless steel	89-97	MXV14332	£25.00
Ashtray surround and window switches	89-97	MXV14333	£36.40



PRODUCT	MODEL	PART NO	PRICE
Electric window switches retro	89-97	MXV14334	£69.00

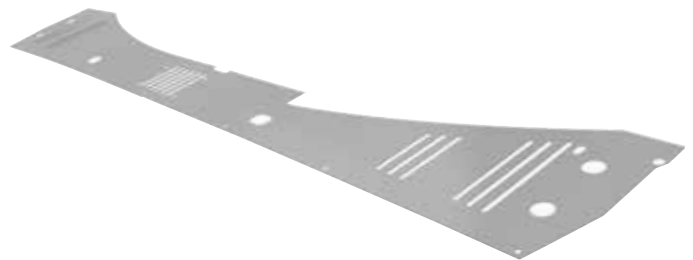

PRODUCT	MODEL	PART NO	PRICE
Windscreen scuttle panel, stainless steel	89-97	MXV14091	£80.00



PRODUCT	MODEL	PART NO	PRICE
Tow hook rear polished, stainless steel	98-05	MXV14023	£35.40
Tow hook rear polished, stainless steel	89-97	MXV14022	£39.00
Tow hook rear, red	89-97	MXV14021	£47.50
Tow hook front polished, stainless steel	89-05	MXV14012	£28.10
Tow hook front, red	89-05	MXV14011	£43.50



PRODUCT	MODEL	PART NO	PRICE
Oil filter removal tool (Mazda fitted two sizes of filter from 89-05 so you will receive both sizes)	89-05	MXV14122	£24.85



MXV14320

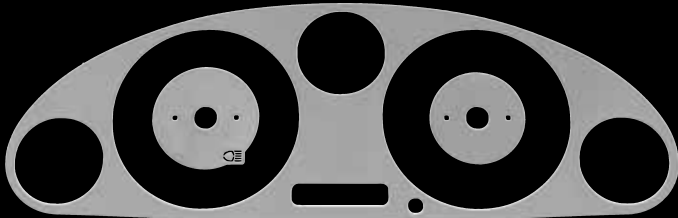

MXV14315

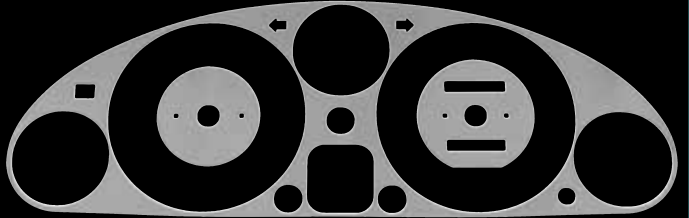

MXV14312

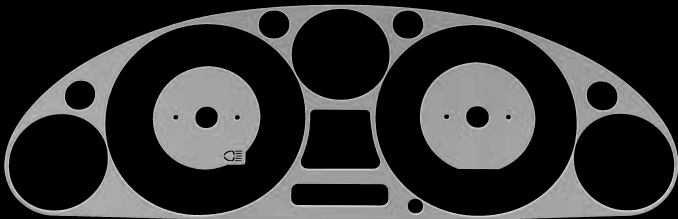

MXV14314

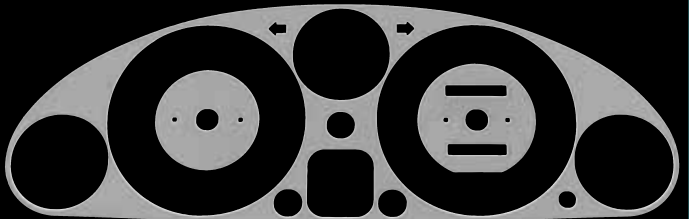

MXV14311

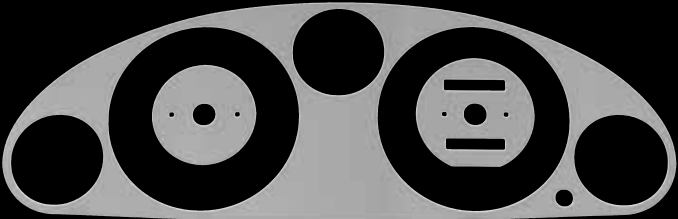

MXV14313

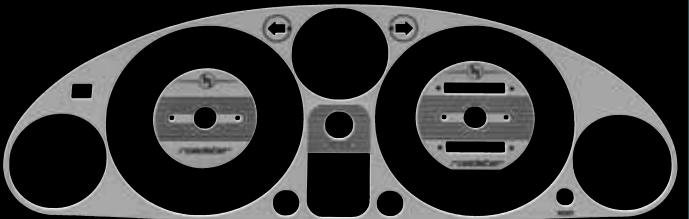

MXV14321

PRODUCT	MODEL	PART NO	PRICE
Instrument cluster bezel engraved (Engraved stainless steel plates for tachometer and speedometer)	89-93 1.6	MXV14320	£41.00
Instrument cluster plain (Stainless steel, plain but thicker for better support if doing a custom LED install or chrome rings)	98-05	MXV14315	£43.70
Instrument cluster plain (Stainless steel, plain, comes with plates for tachometer and speedometer)	98-05	MXV14314	£39.46
Instrument cluster plain (Stainless steel, plain but thicker for better support if doing a custom LED install or chrome rings)	89-97	MXV14313	£46.80

PRODUCT	MODEL	PART NO	PRICE
Instrument cluster plain (Plain, comes with stainless steel plates for tachometer and speedometer)	94-97 1.8	MXV14312	£30.00
Instrument cluster plain (Plain, comes with stainless steel plates for tachometer and speedometer)	89-93 1.6	MXV14311	£31.20
Instrument cluster engraved (Engraved stainless steel plates for tachometer and speedometer)	94-97 1.8	MXV14321	£50.00

89-97 NA Mk1 | 98-05 NB Mk2/2.5 | 05-15 NC Mk 3/3.5/3.75 | 16> ND Mk4

LONDON 020 8867 2020 BRADFORD 01274 539 999 BRISTOL 0117 923 2523 MANCHESTER 0161 480 6402 PARIS 01 30 80 20 30



EXEDY STOCK CLUTCH KIT

Mazda used Exedy clutches as OEM; these are the same replacement clutches.

PRODUCT	MODEL	PART NO	PRICE
OEM replacement clutch	89-93 1.6	MM900-135	£193.80
OEM replacement clutch	94-05 1.8	MM900-136	£142.80
OEM replacement clutch (5 speed cars only)	05-15	900-137	£185.00
OEM replacement clutch (6 speed cars only)	05-15	900-138	£260.00



EXEDY PERFORMANCE CLUTCH KITS

Exedy racing clutches only use premium friction materials that are resistant to slippage and burst. Increased clamp loads give the necessary capacity to handle modified engines. Stage 1 uses organic material for street and light track use, for up to 30% more torque than stock. Drivability is similar to the stock clutch. Pedal efforts will be slightly higher because of the higher clamp loads. All of the clutch discs have spring centre dampers to reduce drivetrain shock.

PRODUCT	MODEL	PART NO	PRICE
Stage 1 organic clutch kit (125 ft-lbs)	89-93 1.6	916-215	£428.40
Stage 1 organic clutch kit (180 ft-lbs)	05-15	916-217	£390.00
Alignment tool	89-05	387-205	£7.30



CLUTCH MASTER CYLINDERS

PRODUCT	MODEL	PART NO	PRICE
MK1-2.5 OE	89-05	902-300	£109.99
MK1-2.5, Aftermarket	89-05	902-630	£40.80
MK3 OE	05-15	903-246	£114.98
MK3 Aftermarket	05-15	903-248	£61.20



CLUTCH SLAVE CYLINDERS

PRODUCT	MODEL	PART NO	PRICE
MK1 up to VIN 111969, Aftermarket	89-90	903-150	£22.85
MK1 from VIN 111970: MK2-2.5, Aftermarket	90-05	MXV8127	£30.00
MK3 OE	05-15	903-245	£48.95
MK3 Aftermarket	05-15	903-247	£28.60

Visit moss-europe.co.uk for latest prices



MXV6001

994-060

COBALT
PRECISION AUTOMOTIVE

COBALT SHORT SHIFTER

The MX-5 has a great gearbox; Cobalt has succeeded in making it even sportier! Cobalt's zinc-plated billet steel sport shift kit reduces shift throw by 25% and can take the constant yanking and jerking unlike billet aluminium shifters that have been known to break. Shifting is even easier with a simple flick of the wrist. To ensure OEM quality and performance they supply a new dust boot, bushing and washers with their sport shifter. Complete with instructions and ready to install. Knobs sold separately, or reinstall your stock knob.

PRODUCT	MODEL	PART NO	PRICE
Short shifter 5 speed	89-05	MXV6001	£75.00
Short shifter 6 speed	05-15	994-060	£125.00



909-930

909-932

770-823

994-010

907-183

SHIFTER REBUILD KITS & SPARES

Our rebuild kit is a mix of OEM Mazda and aftermarket pieces to keep the cost much lower than the full Mazda kit. If your shifter is getting sloppy, replace all your boots and bushings, clean the turret and refill with new fluid for super smooth shifting.

PRODUCT	MODEL	PART NO	PRICE
Shifter rebuild kit (5 speed cars only)	89-97	909-930	£63.46
Shifter rebuild kit (5 speed cars only)	98-05	909-932	£63.46
Lower gear lever boot	89-05	770-823	£14.40
Upper gear lever boot	89-05	994-010	£14.84
Lower gear lever bush (5 speed cars only)	89-15	907-183	£7.20



994-020

994-021

fidanza
Hybrid specialists

FIDANZA CAM GEARS

Fidanza adjustable cam gears are made from 6061 T6 billet aluminium for strength and light weight. The gears feature 12 degrees of adjustments while most only feature 10, so you can tune your MX-5's engine for the best power output. CNC machined for precise fit and finish, and the outer gear is hard anodized for strength.

PRODUCT	MODEL	PART NO	PRICE
Aluminium cam gears (Sold each, fits intake and exhaust)	89-97	994-020	£122.00
Aluminium cam gears (Sold each, only fits exhaust)	98-00 1.8	994-020	£122.00
Red cam gears (Sold each, fits intake and exhaust)	89-97	994-021	£122.00
Red cam gears (Sold each, only fits exhaust)	98-00 1.8	994-021	£122.00



909-630

909-631

MOROSO

MOROSO OIL CATCH CAN

Your MX-5 isn't running as cleanly as you thought, and this air-oil separator from Moroso is what you need to clean it up. The factory designed the engine to vent excess vapours and oil back into the intake manifold, causing oil deposits that gunk up the intake and the valves, and crankcase vapors which could cause detonation. Plumbing this air-oil separator into the PCV system captures the oil and moisture and contains it in this great looking billet canister.

- ▶ Billet aluminium construction has a raw finish
- ▶ Supplied with 3/8", 90° inlet & outlet fittings and 36" of 3/8" rubber hose
- ▶ Includes billet aluminium mounting clamp
- ▶ Canister unscrews for draining and cleaning
- ▶ Moroso name you can trust for great engineering and machining

PRODUCT	MODEL	PART NO	PRICE
Polished	89-05	909-630	£161.30
Black anodized	89-05	909-631	£161.30



907-301

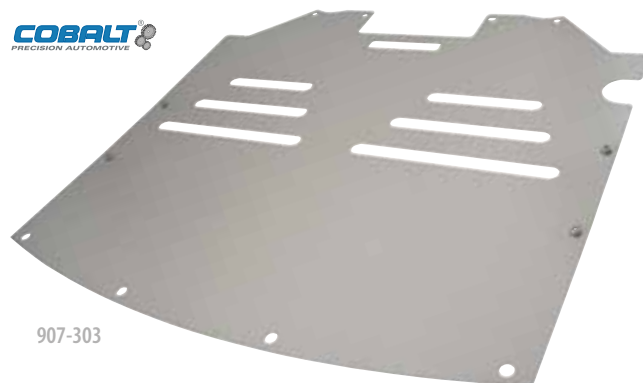

907-302

COBALT
 PRECISION AUTOMOTIVE

907-303

SKID PLATES

The MX-5 comes with a flimsy plastic engine undertray that is prone to deterioration and cracking. Once this factory piece is compromised dirt, debris and excessive amounts of water can get on your engine and belts leading to increased maintenance. The other function of an engine undertray is to direct air through your radiator and not let it escape under them. Cobalt engineers have developed a replacement shield to protect your engine, radiator, and all other vital engine parts from damage. Using stainless steel construction to ensure it is a rock solid addition to your MX-5, the Cobalt engine shield will perform the same functions as your original undertray - only better. The Cobalt shield reuses your factory bolts and screws. Upgrade to the bright kit to really finish off the beautiful look. Kit includes zinc-coated metric hardware to replace those grungy OEM bolts.



903-792



I.L. MOTORSPORT

SPARK PLUG COVER BY I.L. MOTORSPORT

Clean up the look of your MX-5's engine bay with this stainless steel piece that goes over your spark plug wires.

PRODUCT	MODEL	PART NO	PRICE
Cobalt skid plate/undertray	98-05	907-301	£112.00
Cobalt skid plate/undertray	05-15	907-303	£130.00
Undertray fitting kit	89-05	907-302	£11.00

PRODUCT	MODEL	PART NO	PRICE
Stainless steel plug cover	89-97	903-792	£54.05

Visit moss-europe.co.uk for latest prices



RETRO SOUND RADIOS

The RetroSound range of radio & MP3 players maintain the original 'twin knob' (DIN-D) style mounting required for many classic cars. Music can be played from external sources such as iPods, USB flash drives & SD cards, all connected out of sight.

San Diego

DAB/DAB+ Tuner (DAB antenna or DAB Antenna Adaptor required), AM/FM Tuner, iPod/iPhone & Android compatible, Bluetooth, x2 USB ports & x2 Auxiliary inputs. 32,000 colour LCD with built in amp (25 watts RMS/45 watts peak x 4 channels).

Requires DAB adaptor (sold separately).

PRODUCT	PART NO	PRICE
RetroSound San Diego - chrome	230-383	£315.00
RetroSound San Diego - black	230-388	£315.00
RetroSound DAB antenna adaptor	230-389	£18.00



907-302



230-334



230-34

FACEPLATE AND KNOB KITS (F&K KITS)

These kits let you finish off your RetroSound radio with the faceplate and knobs that match the original trim of your classic car. Knobs are available on their own as replacements.

PRODUCT	PART NO	PRICE
F&K kit - chrome faceplate/chrome knobs	230-326	£33.25
F&K kit - black faceplate/black knobs	230-327	£33.25
F&K kit - black/black faceplate/chrome knobs	230-329	£33.25
F&K kit - black/chrome faceplate/black knobs	230-328	£33.25
F&K kit - black/chrome faceplate/chrome knobs	230-333	£33.25
F&K kit - black/chrome faceplate/black/chrome knobs	230-334	£33.25
F&K kit - Becker pinstripe	230-341	£33.25
F&K kit - Blaupunkt black	230-342	£33.25
F&K kit - Blaupunkt black/chrome	230-346	£33.25
F&K kit - VW ivory	230-343	£33.25
F&K kit - Ghia chrome	230-344	£33.25
Knob set only - chrome	230-331	£33.25
Knob set only - black	230-332	£33.25

Long Beach

AM/FM Tuner, iPod/iPhone & Android compatible, Bluetooth, x2 USB ports & x2 Auxiliary inputs. 32,000 colour LCD with built in amp (25 watts RMS/45 watts peak x 4 channels).

PRODUCT	PART NO	PRICE
RetroSound Long Beach - chrome	230-381	£315.00
RetroSound Long Beach - black	230-386	£315.00

Hermosa

AM/FM Tuner, iPod/iPhone & Android compatible, x1 USB ports & x2 Auxiliary inputs. Dual colour LCD display (white and green) with built in amp (25 watts RMS/45 watts peak x 4 channels).

PRODUCT	PART NO	PRICE
RetroSound Hermosa - chrome	230-390	£233.60
RetroSound Hermosa - black	230-395	£233.60



230-550

RETROMOD 8" SUBWOOFER

The compact design and powerful bass response make this ideal for under seat mounting and numerous other in-car applications. The rigid die cast aluminium chassis and powerful Class D amplifier allows this sub to reproduce low frequencies down to 35Hz.

PRODUCT	PART NO	PRICE
8" Subwoofer with internal amplifier	230-550	£189.00



TRACK DOG
RACING

SPLITTERS FROM TRACK DOG RACING

Air Splitters are designed to help protect your front bumper and air dam. Modern bumpers are made from flexible urethane to allow flexing when bumped - but the painted surfaces are still vulnerable to scratches and scrapes. Air Splitters help protect your bumper by extending the protection around the front perimeter. The original Splitter is made from 1/8" thick, high-impact ABS plastic and the extreme version in 1/4". The top surface has a black texture finish, while the underside has a smooth finish that slides easily over steep approach angles.

PRODUCT	MODEL	PART NO	PRICE
Extreme splitter (Fits with factory air dam/spoiler)	89-97	904-881	£112.20
Radical (Fits with factory air dam/spoiler)	89-97	900-292	£219.30
Extreme (Fits with factory air dam/spoiler)	98-00 MK2	900-287	£122.40
Radical (Fits with factory air dam/spoiler)	98-00 MK2	904-597	£193.80
Splitter (Fits with factory air dam/spoiler)	01-05 MK2.5	900-289	£98.90
Splitter (Fits cars with Mazdaspeed front spoiler)	01-05 MK2.5	900-291	£132.60
Radical (Fits cars with Mazdaspeed front spoiler)	01-05 MK2.5	900-293	£204.00



909-055



905-365

R SPEED LIP SPOILERS

Stylish air dam captures the form and function of your MX-5. Molded from ultra tough polyurethane for strength and flexibility. The air dams not only look great but help your MX-5 stick to the road at speed. Parts supplied in ready to install black.

PRODUCT	MODEL	PART NO	PRICE
R Speed front lip	89-97	900-969	£173.40
R Speed rear lip (2 piece kit designed for single exit exhaust cars)	89-97	905-365	£159.50

TOUGE RUN LIP SPOILERS TOUGE RUN

Put a popular and sporty look on your MX-5 without fearing driveways! Our lip spoiler is made from strong and durable polyurethane, unlike others that are made from fragile fiberglass. Comes ready to paint or leave black as an accent.

PRODUCT	MODEL	PART NO	PRICE
Touge Run front lip	89-97	909-055	£178.50

Visit moss-europe.co.uk for latest prices



TSI'S

We have taken our favourite Turn Signal Intakes and made them even better! We have improved the design for excellent fitment. We've also improved the finish; they are now a smooth glossy black finish ready to bolt on. If you do intend to paint match to your car we still recommend professional prep and paint work. Replace your front turn signals with a pair of these clever intakes that supply cool air into your engine compartment. Please Note: For use in Europe the sidelights will need relocation.

PRODUCT	MODEL	PART NO	PRICE
TSI's	89-97	903-202	£75.00



REAR OVERFENDERS

Full rear overfenders made of Fibreglass, 30mm wider than standard that allows fitting 15x8" or 15x9" depending on your wheel offset and tyre set-up. Made in the UK.

PRODUCT	MODEL	PART NO	PRICE
MK1 wide overfenders	89-97	MXV15012	£220.00



MXV16010



MXV16020

PROJECT M BOOT SPOILERS

Project M - Hand crafted, original designs for the MX-5 & Miata since 2009, Made in the UK.

PRODUCT	MODEL	PART NO	PRICE
Ducktail boot spoiler	89-97	MXV16010	£125.00
Ducktail boot spoiler	98-05	MXV16020	£125.00



MXV14428



MXV14421



MXV14424



MXV14425



MXV14426

MIRRORS

Pick one of our three styles of mirror to suit your MX5. We offer Raydyot, Round and F1 Style mirrors. Available with Flat or Convex glass and different finishes.

Please note: Some cars may require the centre hole on the car widened to fit these mirrors. Supplied as pairs and with fittings.

PRODUCT	MODEL	PART NO	PRICE
Chrome Round door mirrors, convex	89-05	MXV14421	£43.00
Chrome Round door mirrors, flat	89-05	MXV14423	£43.00
Satin Raydyot door mirrors, flat	89-05	MXV14424	£47.00
Polished Raydyot door mirrors, flat	89-05	MXV14425	£57.00
Black F1 door mirrors, flat	89-05	MXV14426	£47.00
Black F1 door mirrors, convex	89-05	MXV14427	£47.00
Carbon Fibre look F1 door mirrors, flat	89-05	MXV14428	£47.00
Carbon Fibre look F1 door mirrors, convex	89-05	MXV14429	£47.00



648-200



648-205



648-215



648-220



648-210



903-983

OE BADGES

Genuine badges from Mazda Japan add style to your MX-5. Our supercharged badges let others know your MX-5's serious.

PRODUCT	MODEL	PART NO	PRICE
Rear badge Red Roadster (Genuine Mazda)	89-97	648-200	£22.85
Rear badge Black Eunos (Genuine Mazda)	89-97	648-205	£30.20
Rear badge Black Roadster (Genuine Mazda)	89-97	648-215	£22.45
Rear badge Black Roadster (Genuine Mazda)	98-05	648-220	£17.80
Supercharged	All	648-210	£17.00
Mazdaspeed decal (Measures 36" in length)	All	903-983	£17.00



BICYCLE RACK

This universal bike rack installs in minutes and holds up to three bikes securely.

PRODUCT	MODEL	PART NO	PRICE
Bicycle rack (Will not fit MX-5's with lip or wing style spoilers)	All	900-310	£94.50



901-610



MXV1074X

BOOT RACKS

Going away this summer? Then fear no more about lack of space by installing one of our stainless steel bootracks. Designed to be easy on/off and will not mark the bodywork. No drilling required.

PRODUCT	MODEL	PART NO	PRICE
Stainless steel boot rack (Not suggested for use with PRHT. Will not work with spoiler. No drilling required)	05-15	901-610	£158.00
Stainless steel boot rack (No drilling required)	89-97	MXV1074X	£249.60
Stainless steel retro boot rack (No drilling required)	98-05	MXV1075X	£218.40

Visit moss-europe.co.uk for latest prices



BOOT LID POCKET POD

Ingenious design mounts inside your boot and contains 3 storage pockets. Constructed of durable nylon, each pocket system has 2 locks to keep items stowed securely. The Pocket Pod™ is a great place to keep necessity items such as an umbrella, jumper cables and car care accessories.

PRODUCT	MODEL	PART NO	PRICE
Pocket pod	89-97	906-240	£116.30

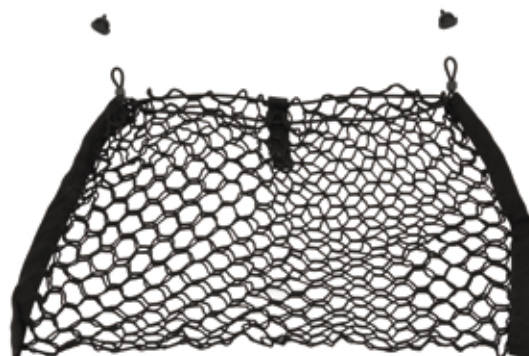

CARGO NET

Trap small items that tend to roll around your boot in a cargo net. Attaches to the boot lid hinges and opens at the top for easy stuffing.

PRODUCT	MODEL	PART NO	PRICE
Cargo net	05-15	900-752	£71.40



HEATED BLANKET

The Comfy Cruise 12 volt heated travel blanket is the ideal travel companion for all weather conditions. Offering both comfort and warmth, its 42" x 58" size is large enough for two people and is perfect for warming one bench seat or two bucket seats at a time. Features an 8 foot long fused cord and automatic temperature control. Made of 100% high quality polyester fleece. Great for cold winter morning starts or long hauls, the Comfy Cruise will provide warmth, whether it's plugged in or not.

PRODUCT	MODEL	PART NO	PRICE
Heated blanket	All	002-842	£35.40



BOOT POCKET POD

Ingenious design mounts to underside of your boot lid and contains 3 storage pockets. Constructed of durable nylon, each pocket system has 2 locks to keep items stowed securely. The Pocket Pod™ is a great place to keep necessity items such as an umbrella, jumper cables and car care accessories.

PRODUCT	MODEL	PART NO	PRICE
Boot Pocket Pod	05-15	906-242	£121.40



THE COOL BREEZE SCOOP

Do you find yourself hot and uncomfortable even though the top is down? Are you constantly trying to scoop in air with your hand from above the windshield or through the window? The Cool Breeze scoop forces fresh air in over the console and into the foot wells. The Cool Breeze scoop is an easy-on/easy-off accessory that takes less than 10 seconds to install and fits easily in your glove box when not in use. The Cool Breeze scoop is moulded from an automotive ABS/Polycarbonate



composite plastic. It is non-reflective black with a textured finish. It can be primed and painted in a colour of your choice with flexible bumper paint, but looks great the way it is delivered.

PRODUCT	MODEL	PART NO	PRICE
Cool Breeze scoop	89-05	904-510	£35.40
Cool Breeze scoop	05-15	904-511	£35.40

89-97 NA Mk1 | 98-05 NB Mk2/2.5 | 05-15 NC Mk 3/3.5/3.75 | 16> ND Mk4

LONDON 020 8867 2020

BRADFORD 01274 539 999

BRISTOL 0117 923 2523

MANCHESTER 0161 480 6402

PARIS 01 30 80 20 30



SPAX LOWERING SPRINGS



If you do not wish to fit a complete height adjustable coil over kit but wish to lower your MX-5, these Spax springs are the answer. They will drop the car by 30mm and are 30% stiffer than the standard items giving firmer, flatter cornering. Also, they are progressive wound so give a comfortable ride at low speeds.

PRODUCT	MODEL	PART NO	PRICE
Spring set (Supplied in a set of 4)	89-97	MXV1017X	£176.00

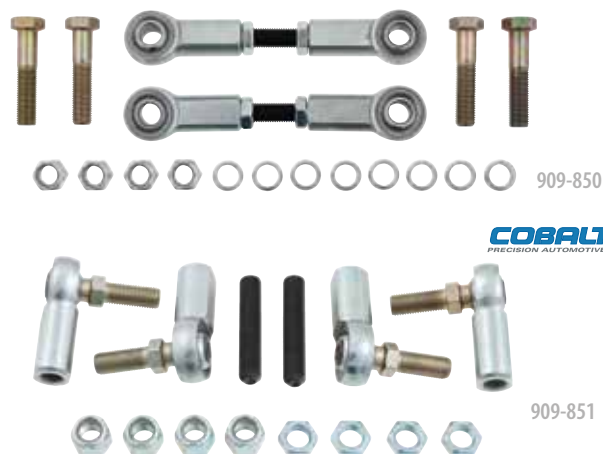

JACKSON RACING ANTI ROLL BARS

These anti-roll bars increase the handling performance of your MX-5 by reducing sway and body roll. Jackson Racing anti-roll bars are high-performance direct replacement upgrades for the factory bars. Both the front and rear bars are adjustable for fine-tuning. Polyurethane bushings and all mounting hardware are included. All Jackson Racing Anti-Roll Bars come with easy-to-read instructions and a lifetime warranty against breakage.

PRODUCT	MODEL	PART NO	PRICE
Front and rear roll bar set	89-97	MXV1184X	£228.00

COBALT ANTI ROLL BAR LINKS

These anti roll bar links are heim-jointed steel with Teflon lining, and help set your car up for more neutral handling by increasing chassis deflection. Each set includes two heim-joint end links, all necessary spacers, Sold in sets of two, two sets required for the whole car. Sold as a pair.

PRODUCT	MODEL	PART NO	PRICE
Adjustable anti roll bar links front or rear	89-97	909-850	£65.30
Adjustable anti roll bar links front or rear	98-05	909-851	£56.10
Adjustable anti roll bar links front	05-15	909-852	£66.30
Adjustable anti roll bar links rear	05-15	909-853	£56.10

COBALT ANTI ROLL BARS

The 3rd generation MX-5 handles well from the factory, but Mazda had to compromise in order to meet the expectations of all potential drivers. As a result, Mazda has left room for improvement even in suspension of cars with the factory Sport package. The addition of Cobalt hollow anti roll bars will reduce your MX-5's body roll, making your MX-5 more responsive to turning, more settled in transitions, and more fun to drive. The Cobalt A/R bar sets stiffness has been

carefully chosen to enhance handling and balance without ruining your ride quality. The rear bar is two position adjustable. Front bar diameter is 25mm and rear bar is 16mm.

PRODUCT	MODEL	PART NO	PRICE
Front and rear roll bar set	05-15	920-330	£220.00

Visit moss-europe.co.uk for latest prices

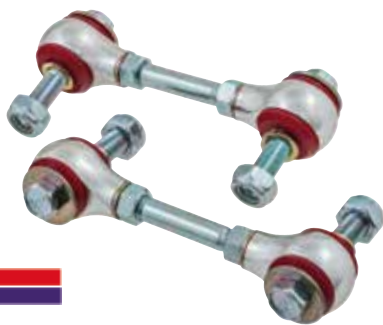

RACING BEAT ANTI ROLL BAR LINKS

A direct swap for the MX-5 factory links and provide the performance enthusiast the ability to set either front or rear anti roll bars to a "neutral position" while the chassis is at ride height to avoid pre-loading of the bar. The experienced enthusiast may wish to purposely "pre-load" the bar to create a specific handling characteristic to induce either a mild understeer or over steer condition. The CNC-machined aluminium end housings are fitted with urethane bushings to further reduce flexing. Each set contains two (2) links to serve one (1) anti roll bar. Sold as a pair.

PRODUCT	MODEL	PART NO	PRICE
Anti roll bar links front	89-97	902-670	£88.00



ANTI-ROLL BAR BRACKETS - HEAVY DUTY

Performance driving can take it's toll on the factory sheet metal anti roll bar brackets causing them to flex, twist and tear. In some instances, the addition of performance roll bar bars can exacerbate the problem. The cure is a pair of heavy gauge replacement steel mounting brackets. Made to fit in place of the original brackets these heavy duty replacements will not flex or twist and are finished in durable black powder coat.

PRODUCT	MODEL	PART NO	PRICE
Brackets	89-05	900-187	£268.30



STRUT BRACES FROM I.L. MOTORSPORT

Strengthen the chassis of your MX-5 with these I.L. Motorsport braces.

PRODUCT	MODEL	PART NO	PRICE
Front upper strut brace If you don't already have a strut brace fitted you (Will require reinforcement panel 901-408)	05-15	907-345	£224.40
Reinforcement plate for 907-345	05-15	901-408	£76.50
Rear upper boot brace	05-15	909-420	£127.50
X brace front	05-15	907-346	£88.20



89-97 NA Mk1 | 98-05 NB Mk2/2.5 | 05-15 NC Mk 3/3.5/3.75 | 16> ND Mk4

LONDON 020 8867 2020

BRADFORD 01274 539 999

BRISTOL 0117 923 2523

MANCHESTER 0161 480 6402

PARIS 01 30 80 20 30

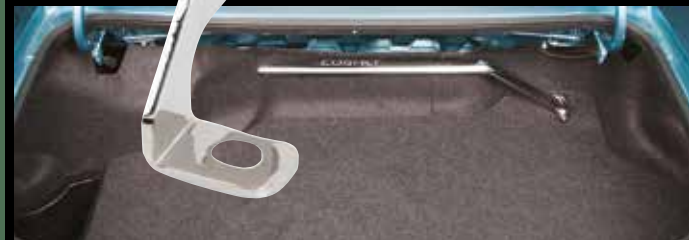

COBALT[®]
PRECISION AUTOMOTIVE



REAR BOOT BRACE

Engineered to work with and match Cobalt's 3-Point Front Shock Brace, this Cobalt Rear Brace is strong and beautiful. Using strong oval section stainless steel tubing this bar ties the tops of the shock towers together for better chassis rigidity. The welds are artfully done and the Cobalt logo is prominent yet understated. This design goes up then over to the shock towers instead of other designs that come forward into the boot space, keeping all of your boot storage open and available. Comes complete with instructions and all necessary hardware.

PRODUCT	MODEL	PART NO	PRICE
Rear boot brace	89-05	909-860	£66.30

SEATBELT TOWER BRACE

Mounts to factory holes and offers more stiffening than the factory brace. Beautifully polished aluminium brace works with Glass window tops, Cobalt Wind Blocker, and the Cobalt Style Bar.

PRODUCT	MODEL	PART NO	PRICE
Seatbelt tower brace	89-05	902-047	£84.00



ENGINE STRUT BRACE 3 POINT

Don't bother looking for a Shock Brace that compares with this one. Oval section stainless steel tubing is mated to beautifully crafted tower supports. The welds on this brace are a work of art! Aside from the best craftsmanship available, this brace actually works. Patterned after Le Mans style chassis bracing, this piece mounts in three places including a special bracket that secures it to the firewall. This ensures rigidity that cannot be duplicated by lesser quality braces that simply mount from shock tower to shock tower. Comes complete with instructions and all necessary hardware. Fits NA, Turbo & JR M45 Supercharged MX-5's! NOTE: Does not fit 90-05 MP62 superchargers. Does not fit 01-05 JR M45 superchargers.



PRODUCT	MODEL	PART NO	PRICE
Engine strut brace 3 point	89-05	904-651	£150.00

Visit moss-europe.co.uk for latest prices



ENGINE STRUT BRACE 3 POINT

Oval section stainless steel tubing is mated to beautifully crafted tower supports. The welds on this brace are a work of art! Aside from the best craftsmanship available, this brace actually works. Patterned after Le Mans style chassis bracing, this piece mounts in three places including a special bracket that secures it to the firewall. This ensures rigidity that cannot be duplicated by lesser quality braces that simply mount from shock tower to shock tower. Comes complete with instructions and all necessary hardware. If you don't already have a strut brace fitted you will require the reinforcement panel 901-408.

PRODUCT	MODEL	PART NO	PRICE
Engine strut brace 3 point	05-15	904-675	£186.00
Reinforcement plate for 904-675	05-15	901-408	£76.50



FRONT LOWER & REAR LOWER BRACES

These braces tie your lower body structure together for better handling and a smooth ride. Installation is simple and straight forward.

PRODUCT	MODEL	PART NO	PRICE
Front lower brace	89-97	MXV1123X	£36.40
Rear lower brace	89-97	MXV1124X	£35.70



PPF POWER KIT

The PPF power kit is an add-on to reinforce the factory PPF (Power Plant Frame) which is susceptible to bending and flexing. By further strengthening the PPF, movement and vibration is reduced in the drive train, especially in higher HP MX-5's. This translates into a more stable platform for delivery of power to the rear wheels. The PPF power kit aids reducing the intensity of the '65 MPH shimmy'. Fits manual transmission only.

PRODUCT	MODEL	PART NO	PRICE
PPF power kit	89-05	904-300	£204.00

89-97 NA Mk1 | 98-05 NB Mk2/2.5 | 05-15 NC Mk 3/3.5/3.75 | 16> ND Mk4



MXV8179



MXV8178

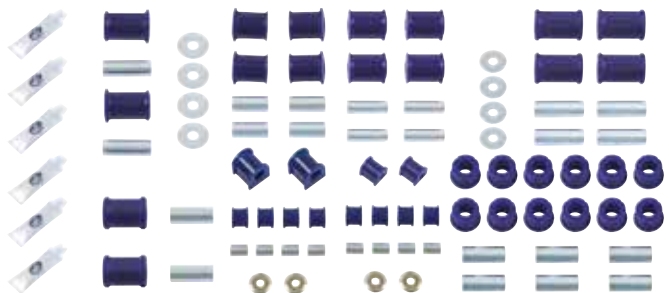

MXV8179

SUPERPRO BUSH SETS AND BUSHES

SuperPro embraces this rich history of innovation and experience in providing solutions and choice that differs and exceeds original equipment or stock components, SuperPro's strong technological capabilities give it the power to give the power of choice back to the individual.

PRODUCT	MODEL	PART NO	PRICE
Complete car kit	89-97	MXV8165	£461.80
Complete car kit (Camber adjustable)	89-97	MXV8166	£551.70
Running gear kit	89-05	MXV8167	£372.20
Running gear kit (Adjustable)	89-05	MXV8168	£372.20
Complete front kit	89-97	MXV8169	£181.20
Complete rear kit	89-97	MXV8170	£280.70
Steering rack mounts (Power steering rack only)	89-97	MXV8178	£27.70
Steering rack mounts (Manual rack only)	89-97	MXV8179	£33.40



MAZDASPEED MOUNTS

Competition parts that were once only available to the MX-5 racing community are now available through Moss Europe. Higher horsepower and aggressively driven MX-5's will benefit from these rubber mounts that are 40% stiffer than stock. Engine mounts will keep everything in line by minimize flexing. This will allow the most power possible to reach the rear wheels. Sold each.

PRODUCT	MODEL	PART NO	PRICE
Upated engine mounts	89-05	903-971	£46.90
Upated differential mounts	89-05	903-972	£69.40



BUMP STOP AND COVER

This bump stop kit includes a universal bump stop with a unique tapered bore. This means it is suitable for all types of shock absorber with rod diameters of anything from 10-22mm. In addition it includes a durable shock absorber cover with ties to secure it to the shock absorber body. This will protect the central shock rod from damage and corrosion. Kit includes 2 bump stops and 2 shock covers.

PRODUCT	MODEL	PART NO	PRICE
Bump stop and cover	89-05	902-610	£36.40

Visit moss-europe.co.uk for latest prices



910-825



Garage star was established in 2005 by Ken Raif. Based in Sacramento, USA, Ken started out manufacturing various Miata goodies for himself and friends mainly as a side job until 2012. With heavy encouragement from the Miata community, Roadster Drift, Club Roadster, and several other online forums, Ken made the leap from his full job in insurance to being 100% dedicated to the GarageStar business.

GarageStar's product list has grown and developed through sponsored driver testing on and off the track. Ken said "A large part of GarageStar's success is due to the help and support of the Miata community."

Ken has always made it a point to give back to the community. He is constantly sponsoring large events such as the Roadster Cup, Speed SF, Historics at Laguna Seca Raceway, and Mazfest.

He is constantly searching for ways to make Miatas faster around the track, lower to the ground on the streets, and "saucier" in the shows. Ken believes listening to customers from around the world enables him to better meet their needs and desires.



910-807



910-845



910-960



910-840

FOR NEW INNOVATIVE PRODUCTS FOLLOW GARAGESTAR ON INSTAGRAM

GARAGESTAR PRODUCT RANGE

PRODUCT	MODEL	PART NO	PRICE
Skid plate for sump	89-97	910-825	£91.40
Carbon fibre slam panel	89-97	910-807	£117.30
Wing braces	89-05	910-845	£219.30
Delrin differential mounts	89-05	910-840	£56.10
Carbon fibre spark plug cover	89-93 1.6	910-820	£132.00
Carbon fibre spark plug cover	94-97 1.8/MK2	910-821	£132.00
Front tow hook version 3.0	89-05	910-950	£66.30
Rear tow hook chassis mount	89-05	910-955	£107.10



910-821

910-820



910-950



910-955



FUEL CAP

Put this fuel cap on and never take it off! This cap has a special spring-loaded door, which allows you to fuel up without removing the cap.

PRODUCT	MODEL	PART NO	PRICE
Permagas fuel cap	89-97	MXV1175X	£11.60



JACKSON RACING FUEL PUMP

When you make more power, you need more fuel. In a standard normally aspirated car, the stock fuel pump delivers just enough, plus a little extra. As the pump ages, it may no longer be able to deliver its full rated capacity. When you add a super or turbocharger, you need more fuel at a higher pressure. Odds are that your stock pump will not meet this demand. The result is a dangerously lean running condition. There are plenty of generic pumps out there, but only the JR High Output Fuel Pump has been specified to deliver the correct amount of fuel. The JR pump is a direct in tank replacement. If you are installing a super or turbo charger, we highly suggest replacing your stock fuel pump at the same time.

PRODUCT	MODEL	PART NO	PRICE
High flow fuel pump	89-97	989-206	£120.70

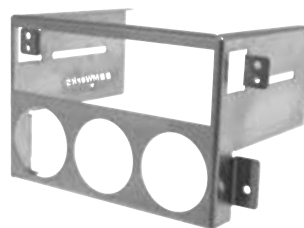

907-172

DDMWorks



907-173

DDM WORKS GAUGE HOLDERS

Add a little style and function to your MX-5! Three upgrades in one - this piece allows for installation of 3 gauges, a strong radio mounting area and your choice of stainless steel or black powdercoat material for a seamless look. Made of 304 stainless steel it is as strong as it is beautiful. Holes fit any standard 2 1/16" gauge and a spot to securely hold your radio in place. Fits all 89-95 MX-5's and 96-97 MX-5's with the factory upgraded radio. (Some aftermarket head units may require some modification of the radio surround for proper fitment.)

PRODUCT	MODEL	PART NO	PRICE
S/S radio and gauge holder	89-97	907-172	£83.20
Powdercoated black radio and gauge holder	89-97	907-173	£83.20

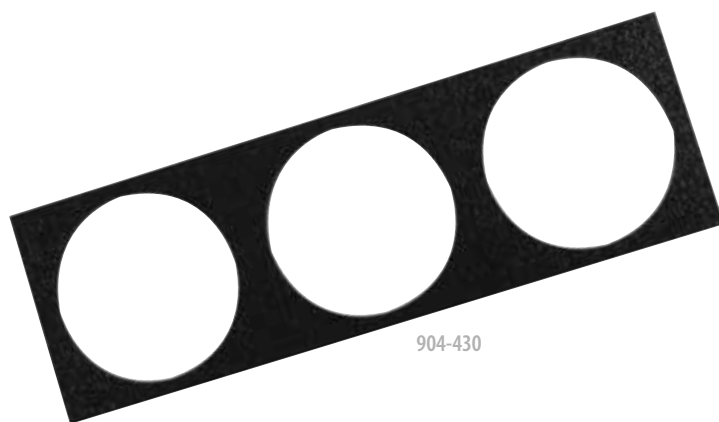

904-430



904-345

TRACK DOG RACING GAUGE HOLDERS

The MX-5 has a perfect spot below the centre air vents to mount gauges. Now we offer this black plastic panel that fits perfectly into that DIN sized radio area. Compatible with both LHD and RHD models.

PRODUCT	MODEL	PART NO	PRICE
Flat 3 gauge panel	89-97	904-430	£38.75
Angled 3 gauge panel	89-05	904-345	£55.20

Visit moss-europe.co.uk for latest prices



MXV18032



MXV18035

MK1 DOOR TRIM PANELS

These handmade door panels are made from 2.4mm automotive hardboard; foam is added and then covered in vinyl as per Mazda original design. All relevant holes are pre-cut.

These door panels are supplied with fitting instructions.

Also available in other colours. Please enquire.

PRODUCT	MODEL	PART NO	PRICE
Black door panels	89-93	MXV18032	£98.80
Black door panels	93-97	MXV18033	£97.30
Black door panels To use with speaker surround	93-97	MXV10834	£98.80
Black door panels Includes front pocket	93-97	MXV18035	£129.40
Black door panels To use with speaker surround + pockets	93-97	MXV18036	£146.60
Black door panels Includes front pocket next to speaker	93-97	MXV18037	£197.60

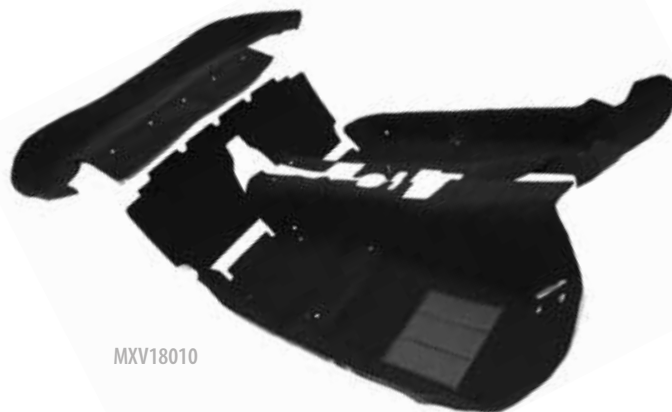

MXV18010

MK1/2/2.5 COMPLETE DELUXE CARPET SETS

These deluxe carpet sets have been developed with several ideas in mind. Originally, the cockpit floor carpet produced by Mazda was a one-piece moulding, but these have been developed as a pair of moulded carpets to be easily fitted to both footwells. These footwell carpets have all the necessary shapes and holes to fit your floor panel exactly as if it were original. By making this kit in two parts, the fitting time is helped as you do not have to take out the dash assembly and also the carriage costs are significantly less.

The second part of this kit is the moulded rear cockpit liner, which will fit exactly as your original and has all the necessary holes for the fasteners to fit into.

The third part of the kit is the bulkhead carpet, which fits behind the seats, and has cloth-bound edges where necessary. The whole kit, when fitted, will totally transform your interior.

Please Note: RHD only. These kits are supplied with a complete set of pictorial fitting instructions with a few tips on removal of your old carpets and fitting ideas of the new carpet set.

Also available in Powder Blue, Blue, Biscuit and Green. Please enquire.

PRODUCT	MODEL	PART NO	PRICE
Black carpet set	89-05	MXV18010	£304.50
Red carpet set	89-05	MXV18011	£304.50
Boot carpet set	89-97	MXV18020	£275.60





101-180

GAC0060

GAC0061

ENGINE START BUTTONS

Get your car started right. Illuminated Engine Start button gives your vehicle that performance car feel. To prevent theft, the engine start button requires the use of your key to switch on the ignition and unlock your steering column. Start button can be installed in place of the cigarette lighter/power outlet. Complete with installation instructions and no drilling required.

PRODUCT	MODEL	PART NO	PRICE
Engine start button illuminated	All	101-180	£17.00
Richbrook engine button	All	GAC0060	£36.40
Richbrook L.E.D engine button	All	GAC0061	£46.60



CHROME VENT RINGS

Supplied as a set of four, these stainless steel Vent Rings spice up your MX-5's interior with some flash and definition. Easily installed in minutes, these rings simply attach using an automotive quality 3M adhesive.

PRODUCT	MODEL	PART NO	PRICE
Vent rings chrome (Sold as a set of four)	89-05	MXV1028X	£11.26



DELTRIN WINDOW BUSHINGS

Over time window guide bushings wear out and the grease in the tracks get gunked up with dirt. If your manual windows are tough to roll up and down your bushes are probably worn. Replacing them is an easy half hour install. Our kit includes a new Delrin bushing for each door.

PRODUCT	MODEL	PART NO	PRICE
Window bushing set (Sold as a pair)	89-05	909-925	£22.25



MXV1189X

MXV1186X

ROSEWOOD GEAR KNOB AND HANDBRAKE SLEEVE

Enhance your interior with this classic style wood gear knob and matching handbrake handle.

PRODUCT	MODEL	PART NO	PRICE
Gear knob (Will not fit automatics)	89-15	MXV1189X	£20.40
Handbrake sleeve	89-05	MXV1186X	£20.40



SUN VISOR BLANKS

For many of us, the Sun Visors in the MX-5 are more of an obstruction than anything else. If you are like many owners who want to remove the sun visors but won't because of the unsightly holes left in the header rail, look no further. Moss has created these indestructible ABS Visor Caps. They install in minutes with a screwdriver.

PRODUCT	MODEL	PART NO	PRICE
Chrome sun visor blanks	89-05	998-260	£3.76
Black sun visor blanks	89-05	901-455	£3.76



CUP HOLDER

Our aftermarket cup holder is a perfect fit for the MX-5 owner on the go. Textured to match your factory console, the cup holder features a rubber mat that fits under the cup holder to catch and retain spills. Install in seconds in place of your factory ashtray.

PRODUCT	MODEL	PART NO	PRICE
Cup holder/coin tray	89-97	MXV1170Z	£17.50



902-255



902-257



902-251



902-258



902-256



902-259



VOODOO GEAR KNOBS

A Voodoo gear knob is the fastest and easiest mod you'll ever make to your car. Improved short-shifting capability is immediate! Voodoo gear knobs have been the enthusiast's first choice for driving enhancement since 1992. Each Voodoo gear knob is a 2 inch sphere of solid aluminium with a choice of finishes.

PRODUCT	MODEL	PART NO	PRICE
Satin/Pearl	89-15	902-255	£40.80
Piano black	89-15	902-257	£40.80
Textured black	89-15	902-258	£40.80
Polished	89-15	902-256	£40.80
Aluminium	89-15	902-259	£40.80



MXV1138X



MXV1139X

ARMREST PAD

Are you tired of resting your arm on that hard centre console? Our armrest pads install in seconds and offer added comfort.

PRODUCT	MODEL	PART NO	PRICE
Armrest pad vinyl	89-97	MXV1138X	£24.70
Armrest pad leather	89-97	MXV1139X	£41.50



231-861

ARM-RESTLER

If you are one of the millions of people who drive with an elbow/arm resting on your vehicle's hard plastic window ledge you are going to love the Arm-Restler™. The Arm-Restler™ will transform your narrow, hard plastic factory door panel into a soft comfortable resting spot!

- ▶ Ergonomic gel armrest provides comfort for your elbow/arm
- ▶ Creates a wide resting surface
- ▶ Use with window up or down

PRODUCT	MODEL	PART NO	PRICE
Arm-Restler	All	231-861	£22.85

89-97 NA Mk1 | 98-05 NB Mk2/2.5 | 05-15 NC Mk 3/3.5/3.75 | 16> ND Mk4

LONDON 020 8867 2020 | BRADFORD 01274 539 999 | BRISTOL 0117 923 2523 | MANCHESTER 0161 480 6402 | PARIS 01 30 80 20 30



Library image



904-545



239-812



238-810



MM900-990

CAR COVERS

Protect your MX-5 from all weather conditions with a protective cover from our range.

PRODUCT	MODEL	PART NO	PRICE
Indoor satin stretch cover	05-15	904-545	£170.00
Outdoor car cover	89-97	238-802	£125.30
Mosom car cover	89-97	238-800	£100.50
Mosom car cover	98-05	238-810	£100.50
Stormproof car cover	89-97	239-802	£196.20
Stormproof car cover	98-05	239-812	£196.20
Stormproof car cover	05-15	904-541	£198.90

HARDTOP HOISTS

PRODUCT	MODEL	PART NO	PRICE
Hardtop hoist	89-05	MM900-990	£39.80
Hardtop hoist	06-15	900-991	£39.80

Visit moss-europe.co.uk for latest prices



904-885

904-886



903-275



AFTERMARKET NUMBER PLATE KITS

No one wants to run a front number plate; it ruins the lines of the MX-5. However, running into trouble by not having one sometimes doesn't seem worth it and we reluctantly give in to the law. The Flip Down number plate holder is the answer. It displays or retracts in one easy motion. When motoring, pull it out and flip it up; when you're at the car show, retract it for the clean look you admire. Now you can also choose a motorised version that operates with the push of a button from inside or outside your car.

PRODUCT	MODEL	PART NO	PRICE
Manual flip kit	89-15	904-885	£43.70
Motorised flip kit	89-15	904-886	£142.80
Relocation kit	05-15	903-275	£74.70



MXV13331



MX513331



NUMBER PLATE PLINTH

Number Plate Replacement plinth, ideal for converting imported cars or replacing cracked and broken plinths. Excellent quality injection moulded ABS plastic makes it strong and easy to fit.

PRODUCT	MODEL	PART NO	PRICE
OE plinth	89-97	MXV13331	£25.90
OE plinth	01-05 MK2.5	MX513331	£25.90



STUBBY AERIAL

If you've ever thought that tall whip-like antenna might be a hazard to unsuspecting eyeballs or a future casualty at a car wash, we've found a perfect solution. The Stubby Antenna is just 3.77 inches tall, super easy to install (unscrew the old, screw on the new Stubby!), machined from billet aluminium and then powder coated for durability, and will not affect radio reception or interfere with satellite radio services. It blends in perfectly with your MX-5's sporty lines but you will notice it every time you look at your Mazda.

PRODUCT	MODEL	PART NO	PRICE
Stubby	89-18	909-676	£27.55



SHORT RAKE AERIAL

Our MX-5's are small and the antenna should be too! Update your MX-5's look with a shorty raked antenna. At just 7" long, the black mast sits at a raked angle, and is easily unscrewed for removal if you have a car cover without a hole. Antenna is wired for power but you may get less radio reception than the stock tall mast antenna.

PRODUCT	MODEL	PART NO	PRICE
Short rake aerial	89-05	906-185	£30.00



REPLACEMENT RUBBER AERIAL

A practical replacement for the factory antenna. Includes a 54" lead.

PRODUCT	MODEL	PART NO	PRICE
Replacement rubber aerial	89-05	900-716	£12.70

89-97 NA Mk1 | 98-05 NB Mk2/2.5 | 05-15 NC Mk 3/3.5/3.75 | 16> ND Mk4

LONDON 020 8867 2020

BRADFORD 01274 539 999

BRISTOL 0117 923 2523

MANCHESTER 0161 480 6402

PARIS 01 30 80 20 30



904-378



001-635



OIL FILTERS

K&N Oil Filter, you can expect heavy duty construction, high flow rates, & outstanding oil filtration.

- ▶ Performance oil filter
- ▶ Long life resin impregnated filtration
- ▶ High flow, high performance
- ▶ 1" welded nut for easy removal with wrench

PRODUCT	MODEL	PART NO	PRICE
K&N oil filter	89-05	904-378	£13.00
K&N oil filter	05-15	001-635	£15.05

OIL FILTER ADAPTER

A perfect solution for anyone that needs additional connections for gauge sending units. This adapter has three ports for sending units. All three ports will accept sending units with American 1/8" NPT (27 TPI) thread or metric taper M10 x 1.0 threads. Machined from aluminium, the adapter is highly polished and the package includes the O-ring seal, the oil filter nipple and tapered plugs for two of the three sending unit ports. Please note that sending units are not included - the sending units in the photograph are there to show how the adaptor can be used. Uses the stock type Mazda oil filter.

PRODUCT	MODEL	PART NO	PRICE
Filter adapter	89-05	904-565	£49.70



909-631



909-630

AIR-OIL SEPARATORS

Your MX-5 isn't running as cleanly as you thought, and this air-oil separator from Moroso is what you need to clean it up. The factory designed the engine to vent excess vapours and oil back into the intake manifold, causing oil deposits that gunk up the intake and the valves, and crankcase gases which could cause detonation. Plumbing this air-oil separator into the PCV system captures the oil and moisture and contains it in this great looking billet canister.

PRODUCT	MODEL	PART NO	PRICE
Alloy separator	89-97	909-630	£161.30
Black separator	89-97	909-631	£161.30

Visit moss-europe.co.uk for latest prices

MK4 UPGRADES

A popular dual tip design is now available from the Cobalt brand! These new exhausts feature a laser-etched Cobalt logo on the tips and carry over all the same great features and sound from the single tip design:

- ▶ 1.2 mm thick polished stainless steel used for exhaust shell, tips, and piping
- ▶ Exhaust packing is a combination of stainless steel wool and fibreglass for a perfect sports car sound that is never intrusive, raspy or drones on the highway
- ▶ Stainless steel used for inner core and perforated tubing
- ▶ 2-3/8" Pipe Diameter
- ▶ Entire exhaust completely polished to a mirror shine
- ▶ Sporty 3-1/2" insulated and polished exhaust tips
- ▶ Easy bolt-on design
- ▶ Gasket included
- ▶ 5-Year Warranty



PRODUCT	MODEL	PART NO	PRICE
Twin exit stainless steel silencer	16-18	910-620	£310.00



910-695

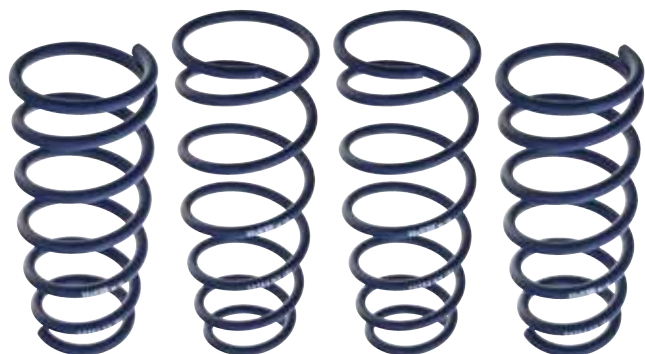

904-305

PRODUCT	MODEL	PART NO	PRICE
N/Plate relocation	2016-	910-745	£51.00
Delrin door bushes (Sold as a pair)	2016-	910-800	£59.20
Eye ball vents satin (3 required per car)	2016-	910-695	£66.30
Factory boot liner	2016-	910-658	£82.50
H&R lowering springs	2016-	904-305	£275.00
VOODOO GEAR KNOBS:			
Satin/Pearl	2016-	902-255	£40.80
Piano black	2016-	902-257	£40.80
Textured black	2016-	902-258	£40.80
Polished	2016-	902-256	£40.80
Aluminium	2016-	902-259	£40.80
Stubby aerial	2016-	909-675	£27.00
Adjustable anti roll bar links front	2016-	909-854	£86.70



910-658



902-255



902-257



902-258



910-800



902-256



902-259



910-745



909-854

GASKETS/SEALS

PRODUCT	MODEL	PART NO	PRICE
Cam cover gasket (Aftermarket)	89-00 1.6	MXV8109	£26.20
Cam cover gasket (Fits MK1 1.8 & all 98-00 aftermarket)	94-00	MXV8108	£17.00
Exhaust manifold gasket (OE, fits all 89-05 1.6 cars)	89-05 1.6	MXV1061X	£19.80
Exhaust manifold gasket (OE)	94-97 1.8	MXV1066X	£16.80
Exhaust manifold gasket (OE)	05-15	903-490	£28.04
Exhaust manifold gasket (Aftermarket)	05-15	903-491	£17.80



903-466

MXV8108

PRODUCT	MODEL	PART NO	PRICE
Exhaust O ring gasket (OE)	99-05	051-633	£12.60
Water pump gasket (OE)	89-05	902-415	£11.60
Water pump gasket (OE)	05-15	903-471	£5.30
Thermostat Gasket (Aftermarket)	89-05	999-023	£2.57
Rear main oil seal (Aftermarket)	89-97	902-375	£29.20
Rear main oil seal with cover (Aftermarket)	05-15	903-466	£43.70
Front camshaft oil seal (Aftermarket)	89-00	971-020	£6.80
Front crankshaft oil seal (Fits cars with the 4 slot crank pulley)	89-91 1.6	971-025	£6.20
Front crankshaft oil seal (Fits all cars up to 2005 with out the 4 slot pulley fitted)	91-05	971-040	£6.20



902-856

MXV1195X

MXV8116

BELTS

PRODUCT	MODEL	PART NO	PRICE
Timing belt kit	89-05	MXV8103	£73.50
Timing belt	89-05	MXV8104	£25.90
Timing belt tensioner	89-05	MXV8106	£26.90
Timing belt idler pulley	89-05	MXV8107	£17.60
Alternator belt	89-93 1.6	GCB20897	£5.62
Alternator belt	94-05	MXV8102	£6.14
PS&AC Belt	89-05	901-816	£7.20

FILTERS

PRODUCT	MODEL	PART NO	PRICE
Oil filter	89-05	MXV8113	£5.62
Oil filter	05-15	902-856	£9.20
Air filter	89-97	MXV8114	£5.12
Air filter	98-05	MXV8115	£6.14
Fuel filter	89-97	MXV8116	£10.40
Fuel filter	98-05	MXV8117	£12.40
Magnetic sump plug	89-05	MXV1195X	£5.30



MXV8104

MXV8106

MXV8107

COOLING

PRODUCT	MODEL	PART NO	PRICE
Thermostat 82c	89-05	MXV8121	£9.30
Radiator cap	89-05	MXV8123	£5.12
Water pump	89-93	MXV8118	£43.00
Water pump	94-05	MXV8119	£52.99
Water pump	05-15	903-470	£68.30
Top hose	94-97 1.8	902-370	£19.80
Top hose	98-05	902-362	£22.00
Bottom hose	89-97	902-360	£14.84
Electric fan switch sensor	89-93 1.6	902-870	£5.40
Oil pressure switch	94-00 1.8 & MK2	MXV8154	£7.20



OUTER PANELS

PRODUCT	MODEL	PART NO	PRICE
Front wing RH (W/Out repeater holes)	98-05	MX53030	£142.50
Front wing LH (W/Out repeater holes)	98-05	MX53029	£142.50
Front wing RH	89-97	MXV3024	£145.00
Front wing LH	89-97	MXV3023	£145.00
Rear arch repair RH	89-97	MXV3027	£79.80
Mudguard repair panel LH	89-97	MXV3038	£79.80
Mudguard repair panel RH	89-97	MXV3039	£79.80



RUNNING GEAR

PRODUCT	MODEL	PART NO	PRICE
Front & rear anti roll bar drop link (Sold each, genuine)	89-97	902-268	£43.70
Rear wheel bearing kit	89-05	MXV8141	£41.40
Front wheel bearing kit (Non ABS cars)	89-05	MXV8143	£79.70
Lower ball joint	89-05	MXV8146	£24.80
Shock boot front & rear (Fits cars with out sports suspension)	89-97	901-025	£13.70



PRODUCT	MODEL	PART NO	PRICE
Rear arch repair LH	89-97	MXV3026	£79.80
Rear arch repair RH	98-05	MXV3033	£81.60
Rear arch repair LH	98-05	MXV3032	£81.60
Outer sill panel RH	89-97	MXV30351	£79.80
Outer sill panel LH	89-97	MXV30341	£79.80

89-97 NA Mk1 | 98-05 NB Mk2/2.5 | 05-15 NC Mk 3/3.5/3.75 | 16> ND Mk4

LONDON 020 8867 2020

BRADFORD 01274 539 999

BRISTOL 0117 923 2523

MANCHESTER 0161 480 6402

PARIS 01 30 80 20 30

BRAKES

PRODUCT	MODEL	PART NO	PRICE
Front left brake caliper (94-05 with out big brake upgrade)	94-97 1.8	907-230	£79.60
Front right brake caliper (94-05 with out big brake upgrade)	94-97 1.8	907-231	£79.60
Rear left brake caliper (94-05 with out big brake upgrade)	94-97 1.8	907-245	£84.70
Rear right brake caliper (94-05 with out big brake upgrade)	94-97 1.8	907-246	£84.70
Front brake disc	89-93 1.6	MXV8131	£25.90
Front brake disc	94-97 1.8	MXV8132	£26.90
Rear brake disc	89-93 1.6	MXV8134	£15.50
Rear brake disc	94-97 1.8	MXV8133	£25.90
Front brake pads	89-93 1.6	MXV8135	£22.80
Front brake pads (Fits MK1 1.8 and all 98-05 cars with out big brakes)	94-05	MXV8136	£24.80
Rear brake pads	89-93 1.6	MXV8138	£16.60
Rear brake pads (Fits MK1.8 and all 98-05 cars with out big brakes)	94-05	MXV8137	£22.80



907-230



907-240



MXV8138



MXV8131



MXV8136



901-905



904-900



904-457



MXV1129X

ELECTRICAL

PRODUCT	MODEL	PART NO	PRICE
Battery	89-05	MXV1129X	£145.00
Electric window switch	89-97	904-457	£73.40

RUBBER

PRODUCT	MODEL	PART NO	PRICE
Exhaust hanger	89-05	901-905	£4.24
Engine mount	89-97	904-900	£59.20
Engine mount (Aftermarket)	89-97	902-620	£33.25
Engine mount	98-05	904-901	£40.80



902-853

ENGINE UNDERTRAY

PRODUCT	MODEL	PART NO	PRICE
Engine under tray (Genuine)	89-05	902-853	£69.00

Ordering from Moss

WHEN ORDERING...

Remember, supplying details of your car, (i.e: engine, commission or VIN, LHD / RHD, year and any modifications) will save time and help us process your order correctly. We will be pleased to provide a full parts quotation, detailing price, availability and shipping costs, upon request.

SHIPPING & DISPATCH

Orders for delivery in the UK may be dispatched by regular post for small/lightweight items, larger items may be dispatched via a courier. Please call us for the best delivery option for your order and the latest delivery prices.

For delivery outside the UK we offer the following services. Economy delivery (by road): 2 to 5 days (approximately). Express delivery (by air): 1 to 2 days (Guaranteed). For small and low value orders we also use airmail. For these services, please ask for prices and the best delivery option when you place your order. Most deliveries (except airmail) are 'trackable', (inc: e-mail updates and internet access for selected carriers). Please remember, all carriage charges are dependent on either gross weight or volumetric weight, whichever is greater. If a quotation is required prior to placing your order, please contact a member of the sales department. Alternatively, you can arrange your own collection.

PRICING

Moss make every attempt to keep prices competitive and stable, however in common with all other suppliers in our industry, we reserve the right to alter prices without prior notice. For the latest prices, please call or visit our website moss-europe.co.uk.

All prices are per unit (unless otherwise stated) and include (UK) VAT at 20% (where applicable). Please note EU countries may be charged at their local VAT rate, countries outside the EU will not be charged VAT. See the ordering information or our website for further details. Prices are correct at the time of going to print, postage & packaging is not included. E&OE.

MOSS UK OPENING TIMES*

Open Monday to Friday 8.30am to 5.30pm

Saturday 9.00am to 1.00pm

*Opening times may vary.

Please call your nearest branch for more information.

See website for Paris opening times.

PICK UP IN STORE

Why not reserve and collect your order in person from one of our four branches?

All you have to do is send an email to sales@moss-europe.co.uk with the title of "Branch Collection"; your e-mail must contain the following information:

- ▶ Your full name, address, daytime contact number, desired branch for collection and part numbers.
- ▶ A member of our sales team will contact you shortly after to let you know that your email has been received.
- ▶ They will then contact you again when your order is ready to collect. You will then be able to collect and pay for your order any time during store open hours from the store stated in your email. On collecting your order you may be asked to confirm your address.

90 DAY MONEY BACK PEACE OF MIND WARRANTY

It's simple, if you change your mind for any reason, all uninstalled parts still in their original condition and packaging may be returned to us within 90 days from the date of purchase for a full refund. A copy of the original invoice or picking label must accompany the return. Return freight is paid by the customer, unless returned due to our error.

In the event of a part failing in use, all parts are warranted against defects in materials and workmanship for 12 months from the date of purchase. Please remember that all returns must be accompanied by the original invoice, return freight will be reimbursed. For more details see our website or contact your local branch.

Keep up to date with our latest news and tell us yours. **Join us on:**

 [facebook.com/mosseurope](https://www.facebook.com/mosseurope)

 twitter.com/mosseurope

 [instagram.com/mosseuropeltd](https://www.instagram.com/mosseuropeltd)

UK WEBSITE
moss-europe.co.uk

FRENCH WEBSITE
moss-europe.fr



LONDON

LONDON

Unit 16, Hampton Business Park, Bolney Way, Feltham
TW13 6DB

London Tel

+44 (0) 20 8867 2020

E-mail

sales@moss-europe.co.uk

Fax

+44 (0) 20 8867 2030



BRADFORD

BRADFORD

Unit 12-13, Acorn Park Ind. Est. Otley Road, Shipley
BD17 7SW

Bradford Tel

+44 (0) 1274 539 999

E-mail

bradford@moss-europe.co.uk

Fax

+44 (0) 1274 539 990



BRISTOL

BRISTOL

1-3, Elton Street
Bristol
BS2 9EH

Bristol Tel

+44 (0) 117 923 2523

E-mail

bristol@moss-europe.co.uk

Fax

+44 (0) 117 942 8236



MANCHESTER

MANCHESTER

111-117, Stockport Road
Stockport, Cheshire
SK3 0JE

Manchester Tel

+44 (0) 161 480 6402

E-mail

manchester@moss-europe.co.uk

Fax

+44 (0) 161 429 0349



PARIS MOTOR DREAM

PARIS

7 rue Chaponval
ZAC du Cornouiller
78870 Bailly, France

Paris Tel

+33 (0) 1 30 80 20 30

E-mail

sales@moss-europe.fr

Sav

+33 (0) 1 30 80 21 50

Moss Website
moss-europe.co.uk

 stores.ebay.co.uk/moss-europe-ltd

 Facebook
[facebook.com/mosseurope](https://www.facebook.com/mosseurope)

 Twitter
twitter.com/mosseurope

 Instagram
[instagram.com/mosseuropeltd](https://www.instagram.com/mosseuropeltd)

Moss Paris Website
moss-europe.fr

DYNOLITE

EUROPE'S CLASSIC MOTOR OIL



Dynolite oil produces high quality oils and lubricants for vintage, classic and racing applications. Including lubricants for engines, gearboxes, steering boxes and greases. Dynolite lubricants are specially developed for historic vehicles to offer far superior mechanical protection.

moss-europe.co.uk

Dynolite Stockist: Moss Europe Ltd



LONDON

LONDON

Unit 16, Hampton Business Park, Bolney Way, Feltham
TW13 6DB

London Tel

+44 (0) 20 8867 2020

E-mail

sales@moss-europe.co.uk

Fax

+44 (0) 20 8867 2030



BRADFORD

BRADFORD

Unit 12-13, Acorn Park Ind. Est. Otley Road, Shipley
BD17 7SW

Bradford Tel

+44 (0) 1274 539 999

E-mail

bradford@moss-europe.co.uk

Fax

+44 (0) 1274 539 990



BRISTOL

BRISTOL

1-3, Elton Street
Bristol
BS2 9EH

Bristol Tel

+44 (0) 117 923 2523

E-mail

bristol@moss-europe.co.uk

Fax

+44 (0) 117 942 8236



MANCHESTER

MANCHESTER

111-117, Stockport Road
Stockport, Cheshire
SK3 0JE

Manchester Tel

+44 (0) 161 480 6402

E-mail

manchester@moss-europe.co.uk

Fax

+44 (0) 161 429 0349



PARIS MOTOR DREAM

PARIS

7 rue Chaponval
ZAC du Cornouiller
78870 Bailly, France

Paris Tel

+33 (0) 1 30 80 20 30

E-mail

sales@moss-europe.fr

Sav

+33 (0) 1 30 80 21 50

Moss Website
moss-europe.co.uk

 stores.ebay.co.uk/moss-europe-ltd

 Facebook
facebook.com/mosseurope

 Twitter
twitter.com/mosseurope

 Instagram
instagram.com/mosseuropeLtd

Moss Paris Website
moss-europe.fr