

Parts & accessories to maintain and enhance your classic

MG T-TYPE



Including over 60 pages
brimming with restoration parts supported
by technical advice & detailed schematics



Performance



Exterior



Interior



Personal



for the latest prices visit moss-europe.co.uk

Ordering from MOSS

WHEN ORDERING...

Remember, supplying details of your car, (i.e: engine, commission or VIN, LHD / RHD, year and any modifications) will save time and help us process your order correctly. We will be pleased to provide a full parts quotation, detailing price, availability and shipping costs, upon request.

SHIPPING & DISPATCH

Orders for delivery in the UK may be dispatched by regular post for small/lightweight items, larger items may be dispatched via a courier. Please call us for the best delivery option for your order and the latest delivery prices.

For delivery outside the UK we offer the following services. Economy delivery (by road): 2 to 5 days (approximately). Express delivery (by air): 1 to 2 days (Guaranteed). For small and low value orders we also use airmail. For these services, please ask for prices and the best delivery option when you place your order. Most deliveries (except airmail) are 'trackable', (inc: e-mail updates and internet access for selected carriers). Please remember, all carriage charges are dependent on either gross weight or volumetric weight, whichever is greater. If a quotation is required prior to placing your order, please contact a member of the sales department. Alternatively, you can arrange your own collection.

UK OPENING TIMES

Open Monday to Friday

9.00am to 5.30pm

Saturday

9.00am to 1.00pm

(Closed Sunday & Bank Holidays)

See website for Paris opening times

COLLECT FROM BRANCH

Why not reserve and collect your order from one of our branches?

ONLINE

If ordering online select the 'collect from branch/ arrange own pick up' option on the 'Delivery Method' page during checkout. Then select the branch you want to collect your order from. You will receive an email confirming your order and selected branch.

EMAIL

Send an email to sales@moss-europe.co.uk with the title of "Branch Collection". Your e-mail must contain the following information: Your full name, address, daytime contact number, desired branch for collection and part numbers.

COLLECTION

Our sales team will contact you when your order is ready to collect. You will then be able to collect and pay for your order at your requested branch during store open hours. On collecting your order you may be asked to confirm your address.

PRICING

Due to the volatility of world markets and currency fluctuations the prices in this catalogue are subject to change.

Moss make every attempt to keep prices competitive and stable, however in common with all other suppliers in our industry, we reserve the right to alter prices without prior notice. For the latest prices, please call or visit our website moss-europe.co.uk.

All prices are per unit (unless otherwise stated) and include (UK) VAT at 20% (where applicable). Please note EU countries may be charged at their local VAT rate, countries outside the EU will not be charged VAT. See the ordering information

or our website for further details. Prices are correct at the time of going to print, postage & packaging is not included. E&OE.

90 DAY MONEY BACK PEACE OF MIND WARRANTY

It's simple, if you change your mind for any reason, all uninstalled parts still in their original condition and packaging may be returned to us within 90 days from the date of purchase for a full refund. A copy of the original invoice or picking label must accompany the return. Return freight is paid by the customer, unless returned due to our error.

In the event of a part failing in use, all parts are warranted against defects in materials and workmanship for 12 months from the date of purchase. Please remember that all returns must be accompanied by the original invoice, return freight will be reimbursed. For more details see our website or contact your local branch.

Keep up to date with our latest news and tell us yours.

Join us on:

 facebook.com/mosseurope

 twitter.com/mosseurope

 pinterest.com/mosseurope

WEBSITE

moss-europe.co.uk

FRENCH WEBSITE

moss-europe.fr



LONDON

Unit 16, Hampton Business Park
Bolney Way, Feltham
TW13 6DB

London Tel

+44 (0) 20 8867 2020

E-mail

sales@moss-europe.co.uk

Fax

+44 (0) 20 8867 2030



BRADFORD

Unit 12-13, Acorn Park Ind. Est.
Otley Road, Shipley
BD17 7SW

Bradford Tel

+44 (0) 1274 539 999

E-mail

bradford@moss-europe.co.uk

Fax

+44 (0) 1274 539 990



BRISTOL

1-3 Elton Street
Bristol
BS2 9EH

Bristol Tel

+44 (0) 117 923 2523

E-mail

bristol@moss-europe.co.uk

Fax

+44 (0) 117 942 8236



MANCHESTER

111-117 Stockport Road
Stockport, Cheshire
SK3 0JE

Manchester Tel

+44 (0) 161 480 6402

E-mail

manchester@moss-europe.co.uk

Fax

+44 (0) 161 429 0349



PARIS

7 rue Chaponval
ZAC du Cornouiller
78870 Bailly, France

Paris Tel

+33 (0) 1 30 80 20 30

E-mail

sales@moss-europe.fr

Sav

+33 (0) 1 30 80 21 50

A	Adjustable oil pressure regulator .A08	Headlamp relay kitsA19	T	Threshold platesA17
AeroscreensA17	HeadlampsA19	Heated blanketA29	Throttle discsA11	Tonneau coversA13
Air filtersA12	HoodsA13	HornsA17	Tool rollsA30	Travel bagsA26
Alfin brake drumsA06	HT leadsA05	HubcapsA21	Travel casesA27	T-shirtsA30
B	I	Ignition lead numbering set ..A04	Tyre valve capsA21	
Badge and lamp barsA14	Interior trimA24		U	Union flagA30
BadgesA14	J	Jack bagsA30	W	Wallets & pursesA27
Bar stoolA28	K	Key fobsA29	Waterproof blanketA29	Wheel cylinder setA05
Battery cut-off switchesA07	Klingersil gasketA08		Wheel trimsA20	Wind wingsA17
Battery tray/linerA07	L	Lamp coversA18	Wine & beer glassesA29	Wire wheel conversion kits ..A21
Books & manualsA26	LampsA18-19	Luggage racksA14	Wire wheelsA21	Wire wheels tools & essentials .A20
Brake servo kitA06	M	MirrorsA16	Workshop apronA28	
C	Model kitsA30	Moto-meter radiator caps ...A09		
Car coversA20	MugsA29	O		
Carburettor accessoriesA11	Oil cooler radiators & kitsA08	Oil filter conversionA08		
Carpets setA24	OvermatsA24	P		
Centre armrestsA24	P	Peak capA29		
Centre lock spinnersA21	Piper air socksA12	Piper air socksA12		
Cigar lighterA29	Plug caps & terminalsA05	PosterA29		
CrankshaftA08	R	Ram pipesA12		
Crankshaft oil seal kitA08	Rev limiterA12	Reverse & fog lampsA18		
Crown wheel & pinion kitA05	Rocker coversA11	S		
D	S	Screw jackA30		
Damper conversion kitA05	Seat belt kitsA24-25	Seat belt shoulder padA30		
Dash kitsA23	Seat cover kitsA24	Shock absorber bush kitA05		
Dashpot coversA12	Shock absorber conversion kit .A05	Side screen coversA13		
DecalsA14	Spin on oil filterA08	Sports coilA04		
DipstickA09	Spot & fog lampsA18	Steering wheel bossesA22		
DistributorsA07	Steering wheelsA22-23	Stone guardsA19		
Driving glovesA27	SunvisorsA17	Supercharger kitA12		
DVDsA26	SwitchesA18			
DynamatA28				
Dynator charging systems ...A04				
E				
EarringsA28				
Embroidered patchesA29				
Exhaust systemsA04				
Exhaust tail pipeA04				
F				
Fan kitA06				
Flying helmet & gogglesA27				
Fuel pump inertia switch kit ..A09				
Fuel pumpsA09				
Fuel regulatorsA09				
G				
Garage signsA28				
Gear knobsA23				
Gear stick gaiter finisher kit ..A23				
Gearbox conversionsA11				
General switchesA18				
Grab handleA23				
Groser jetsA11				
H				
Harness kitsA25				
Headlamp peaksA19				
Headlamp protectorsA19				

Sections

Performance A04

Exterior A13

Interior A22

Personal A26

black & white Restoration Section

Ordering Information 01

Restoration Parts 02



Moss Europe Ltd are proud to support the FBHVC

The Federation of British Historic Vehicle Clubs exists to uphold the freedom to use old vehicles on the road.

Where the price is replaced with NCA this part is Not Currently Available. Please visit our website (moss-europe.co.uk) or call our sales staff for the latest availability information or to enquire if we can offer an alternative part.

MGT001 ©Copyright Moss Europe Ltd. March 2016. Printed in the U.K. All rights reserved. No part of this publication may be reproduced, stored in a retrieval system, or transmitted in any form by any means, electronic, photocopying, recording or otherwise without prior written consent of Moss Europe Ltd. Please note: Product colours may vary slightly to samples featured in this catalogue, due to the limitations of colour printing.

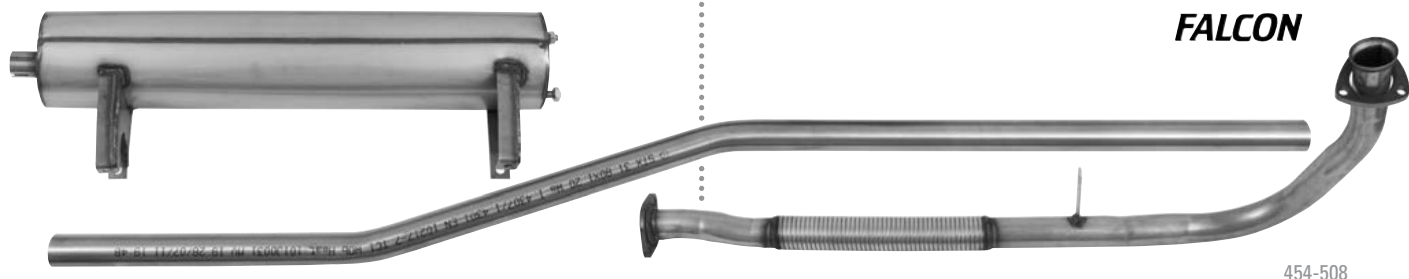

FALCON

454-508

Falcon stainless steel exhaust systems

If you want to keep the standard style of exhaust but you want the longevity of stainless steel, then we recommend using one of our Falcon high quality exhaust systems. For individual replacement components, exhaust

mountings and detailed model specifications, please see the Restoration section.

TB and TC stainless steel system454-508£264.00

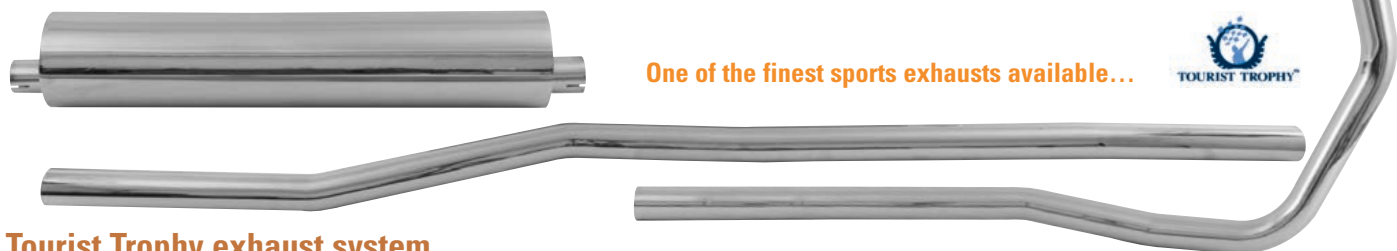

One of the finest sports exhausts available...



Tourist Trophy exhaust system

This beautiful Tourist Trophy polished stainless steel sports exhaust system is available for TD & TF models and is manufactured using the highest quality materials and workmanship. The system features a single silencer with a tail pipe designed to clear the overrider. The box is packed with a combination of stainless steel wire wool and fibreglass, this gives a throaty exhaust note under acceleration that isn't intrusive when cruising.

option, provided that the muffler discloses a manufacturing defect. Warranty is void if any defects are caused by a physical impact of any kind.

- Manufactured from 1.2 mm thick 304 grade stainless steel
- Entire mid-pipe/silencer is polished to a mirror shine
- Tailpipe angled away from the overrider
- 5 Year Limited Warranty (conditions apply)

Warranty info: This system is warranted to the original purchaser of record and for the original vehicle on which the product was installed, against defects in materials and workmanship for 5 years. Moss' sole obligation under this warranty shall be limited to repair or replacement at Moss'

Stainless steel exhaust system - TD & TF454-538£150.20
 Fitting Kit for 454-538 exhaust system454-539£63.00
 Exhaust clamp Mikalor type 1 7/8" (2 required) .TT9933S£2.50
 Hanger (2 required)412-040£15.10



WOSP

Dynator charging system

For owners wishing to fit an alternator but prefer to keep the original appearance for aesthetic reasons, or for competition scrutineering rules, the Dynator is the answer. Basically, it's an alternator in a dynamo casing, and comes complete ready to fit, available for positive and negative earth. Instructions provided.

Negative earth mechanical tachoPT10802TT . .£550.00
 Positive earth mechanical tachoPT10802TTP .£700.00



Ignition lead numbering set

Keep track of which ignition lead is which with a set of useful numbered sleeves.

4 cylinder ignition lead numbering setCRST255£3.70



Exhaust tail pipe trim

If you want that true classic look for your MG exhaust, this high quality stainless steel clamshell shape tail pipe trim is just the thing, with the MG logo.

Exhaust tail pipe trim MG logo224-140£107.40



Sports coil

Sports coils are designed to improve ignition performance. They give more reliable starting power and greater performance at high revs thanks to the 40,000 volt output. Don't forget to renew your plugs and leads to optimise the power. Your HT lead into the coil will need to be the push-in type, use GLC1110 to convert the lead.

Sports coil non-ballast typeTT2981£19.30
 Ignition lead end kit.GCL1110£1.33



Plug caps and ignition lead terminals

Waterproof NGK plug caps in a choice of different angles to suit various applications and a HT terminal kit to fit push-in coils and distributor caps.

Straight plug cap, red (each)NSB5£3.60
Straight plug cap, black (each)NSB5BLK£3.50
60° plug cap, red (each)NYB5£3.60
60° plug cap, black (each)NYB5BLK£3.50
90° plug cap, red (each)NLB5£5.00
90° plug cap, black (each)NLB5BLK£3.50
Ignition lead end kit (each)GCL1110£1.33



TT2982M

Competition HT lead

If you want a performance HT lead with the correct period look then this 'bumblebee' lead is a must. As per the original 'Lucas' type it features a high conductivity copper core with a yellow insulator featuring a black stripe.

Alternatively, use the standard black lead for an 'OE' look. We recommend you assemble leads with NGK suppressed plug caps.

Bumblebee HT lead (per metre)TT2982M£6.00
HT lead (per metre) - blackAAA5981M£2.90



Shock absorber bush installation kit

Installing new Girling shock absorber bushes and link pins has been a great source of frustration for TA, TB, TC owners for years. Replacement bushes available over the years have been either very easy to fit, coming apart just as easily or nearly impossible to fit! Our kit includes detailed instructions.

TA and TC shock absorber bush installation kitMM385-890£66.40
--	----------------	-------------



Wheel cylinder set

The braking power of the typical T-series ranges anywhere between adequate to nightmarish. Moss now offers a complete wheel cylinder set with fantastic build quality that offers stopping performance that your vehicle hasn't seen since it was new.

Not only will your confidence increase when needing to stop, but also your budget will appreciate the cost savings that the complete kit offers over purchasing wheel cylinders individually.

Wheel cylinder set TD-TF180-628£159.40
--------------------------	--------------	--------------



Crown wheel & pinion conversion kit

This complete crown wheel and pinion conversion kit consists of all the major parts needed to convert your TD or TF to the MGA crown wheel & pinion. It should be purchased in addition to the TD-TF crown wheel & pinion interchanges manual (part no. 212-350) which offers a step-by-step guide to converting the rear axle to accept MGA or ZA-ZB crown wheel & pinion. The kit does not include parts for a normal rebuild that may be required, these will need to be purchased separately. The kit includes crown wheel & pinion, spacer, pinion bearings and CW&P nut.

Crown wheel & pinion conversion kit, 4.55:1 - TD-TF102262K£212.00
Crown wheel & pinion interchange manual - TD-TF212-350£212.00



Rear tube shock conversion kit

This telescopic damper conversion kit is designed to give improved ride and damping characteristics to your TD-TF. Featuring Koni adjustable dampers with bespoke brackets and comprehensive fitting instructions. Koni dampers are renowned for their quality and accurate damping control, dampers must be removed from the car to adjust the damping settings.

Koni rear shock conversion kit rear TD-TF267-658£404.50
---	--------------	--------------



Damper conversion kit

This front damper conversion uses MGB front dampers with specially designed and modified upper trunnions.

Please note that this replaces the shocks on Armstrong equipped TDs only, and all TF's. TD's that had Girling dampers cannot use this conversion due to clearance problems. In order to use it, the TD must have the "relief bump" in the front wing to clear the damper body. The kit comes complete with everything needed except bolts to mount the damper. Existing damper mount bolts should be retained.

Damper conversion kit TD & TF264-398£723.20
-------------------------------	--------------	--------------



TT3949

Remote brake servo kit

For those who find the brake pedal rather hard after driving more modern vehicles, these remote servo kits make braking easier by reducing pedal effort. Suitable for all single line brake circuits they are remote mounted and easily plumbed into the hydraulic and vacuum systems of the car. We offer both a Lockheed and aftermarket kit, both are supplied with mounting brackets and hardware.

- Remote brake servo kit LockheedTT3949£180.00
- Remote brake servo kit aftermarketTT3949Z£92.30



Alfin brake drum

These newly available Alfin brake drums for the TC provide extra cooling to improve the braking efficiency, reducing brake fade under heavy braking.

- TC Alfin brake drum (each)456-910£315.30



TT294021

Kenlowe fan kit

Kenlowe were the innovators of electric, thermostatically controlled engine cooling fan kits for classic cars. Their powerful fans are designed to give high air flow to aid engine cooling, particularly useful in modern traffic situations.

Fitting a Kenlowe fan will reduce the engine warm up time, prevent excessive cooling and allow the engine to operate closer to its ideal running temperature. Removal of the standard fan will help to reduce engine noise, and will help improve power/mpg. Kenlowe fan kits are recommended as replacements for the mechanical fan where the cooling system is in good condition and there are no overheating issues. Where cooling issues are present then a Kenlowe fan kit may be used as a secondary booster to assist the mechanical fan. However, we recommend that any cooling system problems are addressed and repaired as necessary.

A manual override switch is available separately, allowing the fan to be operated at any time giving maximum control of the engine's temperature. Kit includes fan, motor, thermostatic switch, wiring, mounting hardware and instructions.

- Kenlowe fan kit, 10" (blower)TT294021 . . .£148.80
- Manual override switchTT2948£11.35

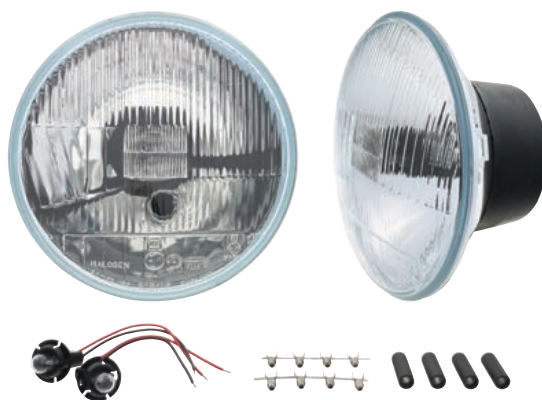

H4 HALOGEN HEADLAMP CONVERSION

For a powerful superior light beam and pattern, fitting modern halogen headlamps is one of the most worthwhile upgrades you can make to your classic.

Our kits include two light units and two 60/55w halogen bulbs. You can fit standard H4 bulbs, or replace them with blue tinted, or

super white xenon. Super white xenon are approx. 30% brighter.



See page A19 for more information

Battery cut-off switches

Battery cut-off switches are a good idea for all cars. Fitting one enables you to quickly isolate the battery and immobilise the car; ideal when working on your car, or if you intend to put your car into storage. Use with a battery conditioner, see our website or our Restoration Tools catalogue.



Battery mounted cut-off switches

These cut-off switches simply mount to the battery post and feature a screw-in knob to break the circuit. Available with a bypass fuse to allow sufficient current to pass to operate clocks, alarms and coded radios, but if any attempt is made to start the car the fuse will blow.

Battery mounted cut-off switchGAC3192X£6.46
 Battery mounted cut-off switch with bypass fuse .GAC31921£9.50



In-line cut-off switches

These cut off switches need to be fitted into the main battery to starter cable. The body of the switch should be mounted securely to the car and cables fitted using the terminal kit.

Period cut-off switch

These are reproductions of the Lucas 'Battery Master Switch' which was a popular accessory on many British classics.

Period battery cut-off switch (short knob)1B2804£27.00
 Period battery cut-off switch (long knob)1B2804L£27.00



Motorsport cut-off switches

Battery cut-off switches are obligatory for competition cars and should be fitted with a cable for remote access.

Battery cut-off switchTT7964£16.85
 Battery cut-off switch race spec (FIA approved) . TT7962£29.50
 Remote cable 6 footTT79621£29.30
 Spare key for switches TT7964 and TT7962 . .TT79641£4.57
 Terminal kit for battery cableTT7964TK£9.50



Battery tray/liner

This clever - yet functional item, completely hides all but the most terminal symptoms of battery box plague. Ribbed for strength, this battery tray not only protects against corrosion, but also makes cleaning around the battery easier.

Battery tray/linerAM7301£35.00



CSI-Ignition distributors

CSI-Ignition distributors offer a fully electronic ignition system built into a modified Lucas 23D4 distributor housing, keeping as near as possible to the original appearance in the engine bay.

Gone are the points and condenser and mechanical advance mechanism, all replaced with a high quality electronic ignition system manufactured using military specification components for durability and reliability. These distributors are maintenance free (no points to adjust), and offer the benefits of, easier starting & smoother running, more torque & power, reduced fuel consumption & emissions. They also eliminate the weaknesses of mechanical timing advance and problems such as points bounce ensuring correct ignition timing throughout the rev range.

"The new range of CSI-Ignition distributors is a breakthrough for classic car ignition systems".

Each CSI-Ignition distributor features 16 easily switchable, optimised ignition curves to allow timing adjustment to suit your car's engine and fuel specifications. Alternative advance curves can be selected to suit your engine's state of tune making them ideal for modified engines. Curves are easily selected using a screwdriver in a rotary switch, with a bright flashing LED indicator to show the selected curve all concealed underneath the distributor cap.

The distributors are also available with an electronic immobiliser system to prevent unwanted starting of the engine. The immobiliser system features a compact receiver, which should be fitted close to the ignition switch but out of sight, and an electronic key.

All CSI-Ignition distributors for MGT Types are specially modified 23D units they feature optimised curves, without vacuum units and will suit standard and modified engines. Please note: Some units may only be available To Order. More details are available on our website, search for CSI-Ignition Distributor.

Optimised 23D4 positive earthCSD5013571 £359.30
 Optimised 23D4 negative earthCSD5013581 £359.30
 Optimised with immobiliser 23D4 positive earth .CSD5013671 £489.00
 Optimised with immobiliser 23D4 negative earth .CSD5013681 £489.00



CSI-Ignition distributors require a coil with minimum resistance of 2.5 ohms. We recommend using our sports coil TT2981 3 ohms. Bypass the ballast resistor if fitted.

Sport coil (3 ohms)TT2981£19.30



235-865

Spin-on oil filter adaptor

Upgrade your TD and TF to use a modern efficient style spin-on cartridge type oil filter. As well as offering better filtration they make oil changes a cleaner and simpler operation. Includes adaptor, seals and fittings, filter not included. Suitable for TD's from (e) 14224 and TF models.

Spin-on adaptor kit235-865£101.26
Oil filterGFE173£4.80

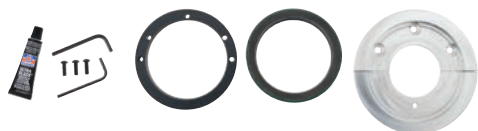

433-421

Crankshaft oil seal kit

This kit replaces the antiquated and inefficient threaded slinger at the rear of the engine, a source of constant and consistent oil leaks. Contrary to other conversions which are presently being sold by others, which require extensive and irreversible modifications, this kit is easily installed when the instructions are followed exactly, and requires the drilling of only one small hole.

TB-TF rear oil seal conversion433-421£180.00
TB-TF replacement seal for above433-422£42.20
TB-TF Speedi sleeve433-425£56.80

(Recommended to fit with 433-421).



Klingersil gasket

These gaskets are manufactured from a modern high performance synthetic material that can withstand much higher temperatures (up to 400°F) and extreme pressures (up to 750psi) making them ideal for fast road and competition engines.

Gasket thermostat housing updated115467X£1.03
-----------------------------------	--------------	------------

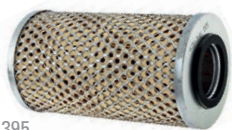

435-395



435-385

Oil filter conversion

This replacement filter assembly for the original TB-TD is a throw away type. The clever design uses inexpensive inserts making the entire package economical in the long run. Suitable for TB-TC and TD models up to (e) 14223.

Oil filter conversion435-385£126.23
Replacement oil filter435-395£8.00



Adjustable oil pressure regulator

This high quality machined period, high performance oil pressure regulator allows external adjustment of the engine oil pressure relief valve spring pre-load.

Adjustable oil pressure regulator435-550£78.80
-----------------------------------	--------------	-------------

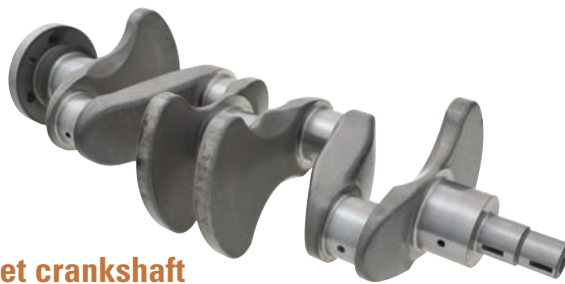

Billet crankshaft

These are the next generation of crankshafts. Engineered in England from solid EN40B steel billets, these crankshafts provide a strong foundation for your engine. The crankshafts are machined using state of the art equipment to original MG specifications. Then the bearing journals are carefully polished before the crank is hardened and tempered to a T condition. Finally it is balanced and Nitrided to the highest quality finish.

Billet crankshaftAAA3105X	£1,670.00
-------------------	---------------	-----------

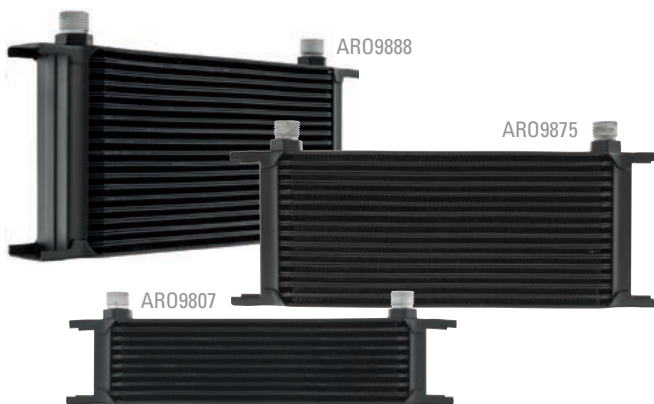

Oil cooler radiators

The oil should be allowed to operate at its optimum temperature, not too hot and not too cold. Choose the one that best suits your purposes.

10 row oil cooler radiator for road useARO9807£66.00
13 row oil cooler radiator for fast roadARA221£38.00
16 row oil cooler radiator for fast road/sprintARO9875£85.00
19 row oil cooler radiator for raceARO9888£92.70

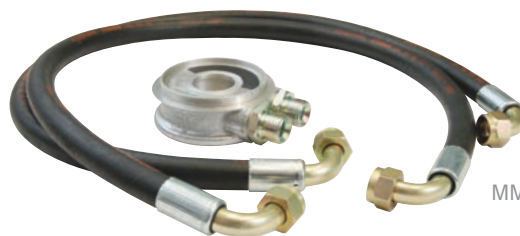

MM235-945

Oil cooler installation kits

Oil thins as the temperature increases, thinner oil reduces oil pressure and is less effective at preventing metal to metal contact. Longer journeys or driving at sustained high speeds, tends to exacerbate the problem. Fitting an oil cooler minimises this effect and helps prevent engine damage. Our kits come with mounting brackets and unions in a variety of styles.

Thermostatic kits include a thermostat so the oil does not go through the cooler until it reaches operating temperature, giving quicker warm up. The radiator is supplied separately so you can choose the most appropriate size. TB, TC and early TD kits are for early vertically mounted oil filter applications. Late style kits incorporate a cast aluminium sandwich plate to fit between the oil pump and filter canister. Oil coolers are normally mounted below the splash apron. (Hose unions are 1/2" BSP).

TB, TC and TD (TD to engine number 14223)	..MM235-935	..£47.20
TD (engine number 14224 on) TFMM235-945	£106.40

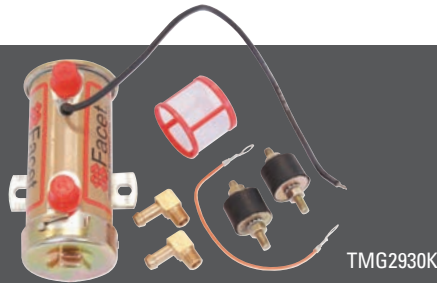

High capacity fuel pumps

The standard fuel pump may not be able to maintain adequate fuel flow and pressure at higher engine speeds, particularly with a tuned engine. The Facet range of fuel pumps will suit all standard and modified engines fitted with carburettors. They give constant fuel flow and pressure, even at high temperatures eliminating the problems associated with vapour lock. The pumps are available in a variety of specifications to suit the engine's fuel pressure and flow requirements. Further fine tuning of the fuel pressure can be easily achieved by the use of a separate fuel regulator, see right. With safety in mind we recommend fitting a fuel pump inertia switch kit, so that in the event of an accident fuel delivery is automatically cut-off. Fuel lines may require adapting to install the new pump, check pipe sizes to select the correct unions, additional unions may be required.

Cylindrical fuel pumps

Formerly known as interrupter type pumps, these heavy duty pumps can be fitted at the front or rear of the car and up to 600mm above the bottom of the fuel tank. Kits are supplied with mounting & 8mm unions, alternative size unions available.

- Cylindrical fuel pump kit - road Silver TopTMG2930K . .£96.00
(Up to 150bhp, flow rate: 30 gal/hr, 4.0-5.50 psi, unions: 8mm x 1/8 npt)
- Cylindrical fuel pump kit - fast road Silver Top . . .MGS2930K .£100.00
(Up to 200bhp, flow rate: 35 gal/hr, 6.0-7.0 psi, unions: 8mm x 1/8 npt)
- Cylindrical fuel pump kit - competition Red Top . .MGS2932K . .£96.00
(Above 200bhp, flow rate: 40 gal/hr, 6.0-8.0 psi, unions: 8mm x 1/8 npt).
- Cylindrical fuel pump only - competition Red Top .TT2930£82.20
(Above 200bhp, flow rate: 40 gal/hr, 6.0-8.0 psi, 1/4 npt threads).

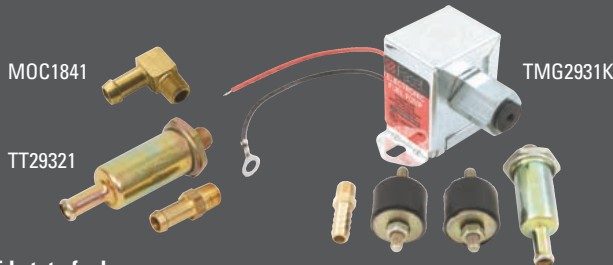

Solid state fuel pumps

These pumps should be mounted at the rear of the car (as they are designed to push fuel rather than draw fuel) and ideally below fuel tank level, although they will work up to 300mm above the bottom of the fuel tank. Kits are supplied with mounting & 8mm unions, alternative size unions available.

- Solid state fuel pump kit - fast roadTMG2931K . .£54.00
(Up to 150bhp, flow rate: 32 gal/hr, 4.5-7 psi, unions: 8mm x 1/8 npt).
- Solid state fuel pump only - fast roadMGS2931 . .£37.50
(Up to 180bhp, flow rate: 34 gal/hr, 7.0-10.0 psi, 1/8 npt threads).

Fuel pump unions

Use with the listed fuel pumps, please check thread and pipe size before ordering.

- Straight union 1/4" (6mm) 1/8 nptFPA903B£1.80
- Straight union 5/16" (8mm) 1/8 nptMOC1604£3.44
- Straight union 3/8" (10mm) 1/4 nptFPA904/B£2.90
- 90° union 5/16" (8mm) 1/8 nptMOC1841£6.10
- 90° unions 5/16" (8mm) 1/4 npt (pair)TT2930A . . .£11.70
- 90° unions 3/8" (8mm) 1/4 npt (pair)FPA902B . . .£11.00

Fuel filter union

- Unions 1/4" (6mm) 1/8 npt (pair)TT29321 . . .£8.40

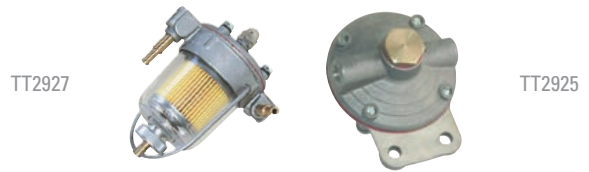

Fuel regulators

We recommend the fitment of a fuel regulator which allows fine adjustment to the fuel pressure to suit your requirements. Use a filter/regulator unless you already have a fuel filter fitted.

- 67mm deep glass filter/regulator 1/4" unions . . .TT2927 . . .£60.00
- 85mm deep glass filter/regulator 5/16" unions . .TT2928 . . .£57.00
- Fuel pressure regulator 1/4" unionsTT2925 . . .£49.50
- Fuel pressure regulator 5/16" unionsTT2926 . . .£51.00



Fuel pump inertia switch kit

This inertia switch is a good safety feature when using an electric fuel pump. The switch unit mounts to a vertical surface in the engine bay and in the unfortunate event of a crash cuts the power to the fuel pump preventing fuel spillage. Supplied with multi connector and tail leads to allow easy connections.

- Fuel pump inertia switch kitC41220AX . .£47.50

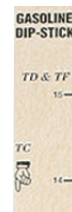

Fuel tank dipstick

A simple yet effective way of ensuring you don't run out of fuel. Calibrated with gallons on one side and car specifications on the back.

- Dipstick, TC TD & TF386-195 . . .£3.91



Moto-meter and radiator cap

This superb product for TA to TD models is not only a well made and good looking accessory, but also very important if your T-Type came out of the factory without the optional water temperature gauge. Available with a choice of plain or 'wreath' design bezels, with or without a cap.

- Moto-meter with wreath bezel and cap230-125 . .£155.30
- Moto-meter with plain bezel and cap230-130 . .£155.30
- Moto-meter with wreath bezel no cap230-103 . .£87.50
- Moto-meter with plain bezel no cap230-104 . .£90.55



MOTO-LITA STEERING WHEELS

Moto-Lita are among the finest replacement steering wheels available. Designed to enhance the appearance of the cockpit and provide an improved feel for the driver.

Available in a variety of styles, including polished or black painted spokes, with the option of polished wood or black leather rims.

Available in 13" to 15" diameters. Boss kits for each specified model of car are required for fitting (available separately).

Moto-Lita

See page A22 for more information



SPORTS EXHAUST SYSTEMS

Tourist Trophy manufacture some of the finest, most durable stainless steel exhaust systems available.

Tourist Trophy polished stainless steel exhaust systems are manufactured using the highest quality materials and workmanship.

These exhausts produce a distinctive 'sporty' exhaust note. Whilst the stainless steel has a mirror polish finish that shines like chrome.

These systems provide a fantastic sound and look stunning.

- High quality manufacture
- Durable stainless steel resistant to corrosion
- Attractive polished appearance
- All systems are covered by a 5 year limited warranty.



See page A04 for more information

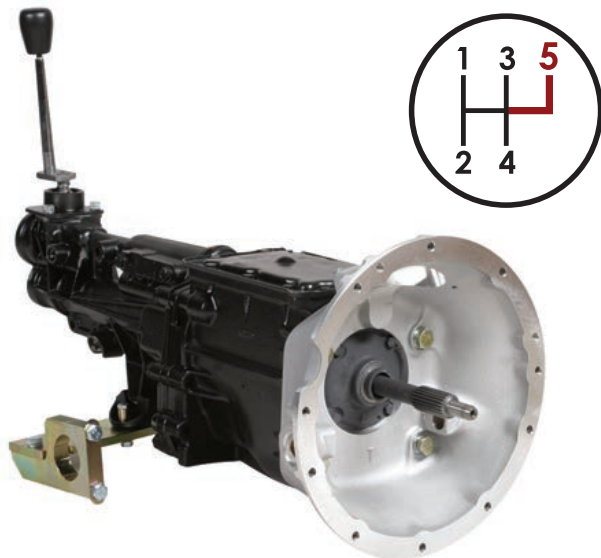

5 speed gearbox conversions

Our precision engineered 5 speed gearbox conversion is based on the Ford Type 9 gearbox and has been designed to make the installation as simple as possible.

The conversion kit is supplied separately to the gearbox assembly and you will need to check your clutch plate diameter before ordering. Conversion kits include a bespoke cast alloy bell housing, brackets and necessary hardware. For full specifications and separate components, please contact your nearest Moss branch or check our website for more details.

Please note: TF models also require a supplemental adaptor kit for the bumper tie bar and fan spacer modifications.

- TC RHD conversion kit 7.25" clutch041-490**£1,328.00**
- TC RHD conversion kit 8" clutch041-491**£1,298.00**
- TD LHD conversion kit 7.25" clutch041-495**£1,422.00**
- TD RHD conversion kit 7.25" clutch041-495RHD**£1,395.00**
- TD and TF LHD conversion kit 8" clutch041-500**£1,269.00**
- TD and TF RHD conversion kit 8" clutch041-500RHD**£1,269.00**

TF adaptor kit041-510**£67.80**
(Use with required conversion kit).

Gearbox assembly - reconditioned041-855**£870.00**
(Outright purchase).



Grose jets for SU carburettors

Grose jets use a more modern ball valve so they won't stick open.

Grose jets for SU H/HS carburettors GAC9201X **£9.50**



Plain throttle discs for SU carburetors

If your throttle discs are fitted with a pop valve these should be replaced with plain discs to maximise air flow through the carburetors on full throttle.

- Plain throttle disc for HS2 WZX1320 **£16.10**
- Plain throttle disc for HS4 WZX1323 **£11.70**



Alloy rocker covers

An alloy rocker cover will improve the appearance of your engine bay and as an added advantage, will help to muffle valve train noise. Always fit a new gasket when replacing your rocker cover, and do not over tighten rocker cover nuts.

The non-finned covers for the TB, TC and TF have provision for the breather fittings to use the original air cleaners. The TD-TF finned cover has no provision for the air cleaner breather pipe. Please refer to the Restoration section for breather system.

- TB and TC non-finned cover with filler cap (MG logo) .224-225**£185.00**
- TD finned cover with filler cap (MG logo)224-226**£180.00**
- TF finned cover with filler cap (MG logo)224-245**£209.00**

- Thumb nut for T-Type rocker cover (MG logo) . .224-250**£18.45**
- TB-TC-TD and TF rocker cover gasket290-300**£10.05**
- TB-TC-TD and TF tappet cover plate224-240**£84.50**
(This chromed tappet cover plate will really enhance your engine bay).
- Brass bolt for tappet plate (MG logo)433-345**£24.00**
- Gasket for tappet cover plate290-600**£5.05**



MG carburettor caps and float bowl bolt

These very distinctive solid brass dashpot damper caps for SU carburetors will improve your engine compartment. Your original damper rod must be re-used and pressed into the new cap. The solid brass float bowl bolt with MG logo complements the MG logo carburettor caps.

- Carburettor caps with MG logo (pair) 370-735 **£44.20**
- Float bowl bolt (each) GAC4149X **£31.65**



Oversized shafts for SU carburetors

Worn throttle shafts and carburettor bodies cause bad idle and uneven running. This can be remedied by replacing your carburetors or by reaming out your carburettor bodies and fitting oversize throttle shafts.

- Oversize throttle shafts for HS4 WZX1177RP **£16.30**
- Carburettor reamer386-385 **£171.20**

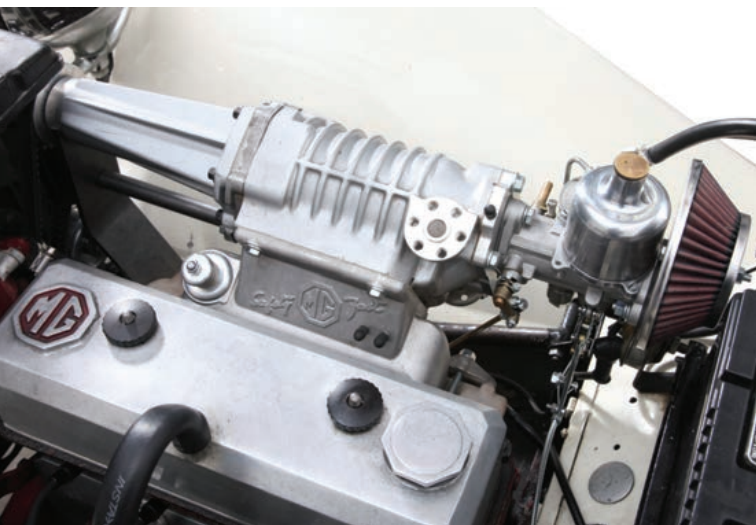

Supercharger kit

Supercharging has a prominent place in British car history, going back as early as the 1920's. In the 1950's and 60's, aftermarket suppliers such as Judson, Marshall, Shorrock and Wade popularized the blower as a reliable method for improving performance. Today, Moss Europe is actively reviving the tradition of supercharged British cars combining old-world attention to detail along with the advances of modern technology.

It has been a number of years since we last offered a TC/TD supercharger. We're proud to announce that a new kit is coming soon, and it's better than ever. Our new, complete supercharger kit is designed expressly for the MG TC/TD, using a modern Eaton blower supplying 5-6 psi of boost. You may expect a horsepower increase of around 40 percent. Step off the line with an authority your car has never known. Power delivery is strong and linear, and smoothness at idle is not compromised.

Appearance is important, so the Moss kit is designed to compliment your car's vintage good looks. We use a period correct 1 1/2" SU carburettor, and a traditional v-belt drive. Everything necessary for installation is included in the kit. Our new intake manifold casting has been designed to optimize flow, and even incorporates a traditional MG factory "Safety Fast" motto. With our step by step installation manual, you can install the kit yourself.

This supercharger system is designed to supplement an engine in good condition, not make up for lost power in a tired one. If your car has an old, fatigued engine you will want to overhaul it first.

Supercharger kit TC-TD150-030 ...**£3,609.00**
 Drive belt, replacement053-356**£15.25**



SmoothCut rev limiters

These rev limiters could save you from an expensive bill. Designed to allow full use of power up to maximum revs, where they will not exceed the preset limit. They work by progressively miss-timing the spark preventing an increase in engine speed from over revving due to missed gears or over exuberance.

SmoothCut rev limiter 4 cylinder preset 6,000rpm .TT2987**£92.59**
 SmoothCut rev limiter adjustable limitRL5**£141.90**



Ram pipes

Ram pipes (except period style) are fitted inside the air filter to help smooth the air flow into the carburettor. The shorter the ram pipe the higher up the rev range power is produced. If using with an air filter, a minimum clearance of 1 1/2" between the ram pipe and the filter case is recommended to ensure maximum air flow.

Ram pipes for SU carburettors

- 1 K&N ram pipe for HS4KN85-5039 ...**£14.40**
- Piper 30mm ram pipe for HS2SFR230**£25.50**
- 2 Piper 30mm ram pipe for HS4SFR430**£25.50**
- 3 Period short ram pipe for HS2SFR1**£15.30**
- Period short ram pipe for HS4SFR2**£15.30**
- Period long ram pipe for HS2SFR4**£15.30**
- 4 Period long ram pipe for HS4SFR8**£15.30**



Dashpot covers for SU carburettors

Dashpot covers are an ideal way to enhance and brighten the engine bay.

- Alloy dashpot cover for HS2SFR22**£10.44**
- Alloy dashpot cover for HS4SFR23**£10.44**
- Anodised blue dashpot cover for HS4SFR23B**£12.85**
- Anodised red dashpot cover for HS4SFR23R**£12.85**
- Chrome dashpot cover for HS4SFR150**£10.44**



Piper air socks

These air socks can be used with our piper ram pipes. They are supplied in pairs at 100mm long. They can be cut to size, though you must leave a minimum of 30mm between the inner face and the ram pipe mouth.

Piper air socks (pair)PXC1050 ...**£26.40**

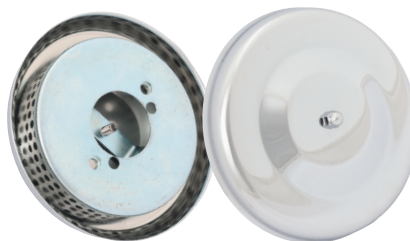

Stelling & Hellings air filters

Stelling & Hellings air filters were a popular aftermarket air filter used on many American hot rods & sports cars. Their filters were supplied as original equipment on the 427 Cobra. Exact reproductions of the period chrome plated slim line filters as used on T-Types.

- Stelling & Hellings air filter - SU 1 1/4" carbs (each) .223-100**£39.00**
- Stelling & Hellings air filter - SU 1 1/2" carbs (each) .223-200**£39.00**



241-255

Tonneau covers

Protect your interior from prying eyes and the harmful effects of the sun's rays when parked with the hood down with a quality tonneau cover made to the original specifications. For full details and hood frame/fixings please refer to the Restoration section. Contact Moss for special requirements.

TA and TB full tonneau duck - black449-260	...£318.00
TA and TB full tonneau duck - tan449-255	...£318.00
TA and TB 1/2 tonneau duck - black449-270	...£226.50
TA and TB 1/2 tonneau duck - tan449-265	...NCA
TC full tonneau duck - black241-140	...£324.00
TC full tonneau duck - tan241-150	...£324.00
TC 1/2 tonneau duck - black241-145	...£232.00
TC 1/2 tonneau duck - tan241-155	...£232.00
TD full tonneau vinyl - black241-220	...£324.00
TD full tonneau duck - black241-240	...£324.00
TD full tonneau duck - tan241-250	...£324.00
TD 1/2 tonneau duck - black241-245	...£232.00
TD 1/2 tonneau duck - tan241-255	...£232.00
TF full tonneau duck - black241-340	...£324.00
TF full tonneau vinyl - black241-320	...£324.00
TF full tonneau duck - tan241-350	...£324.00
TF 1/2 tonneau duck - black241-345	...£232.00
TF 1/2 tonneau duck - tan241-355	...£232.00

Tonneau stowage bags

Tonneau cover stowage bag242-605	...£25.00
Tonneau rail stowage bagAHH6757	...£26.30



256-500

Side screen covers

For full details of side screens frames, strip sets and fixing kits please see the Restoration section.

TA and TB covering kit duck - black449-280	...£394.80
TA and TB covering kit duck - tan449-275	...£394.80
TC covering kit duck - black256-510	...£395.00
TC covering kit duck - tan256-500	...£395.00
TD 2 bow covering kit vinyl - black256-210	...£385.00
TD 2 bow covering kit duck - black256-610	...£395.00
TD 2 bow covering kit duck - tan256-600	...£395.00
TD 3 bow covering kit vinyl - black256-310	...£385.00
TD 3 bow covering kit duck - black256-710	...£395.00
TD 3 bow covering kit duck - tan256-700	...£395.00
TF covering kit vinyl - black256-410	...£385.00
TF covering kit duck - black256-810	...£395.00
TF covering kit duck - tan256-800	...£395.00

Side screen cover stowage bag set

Includes four custom tailored covers made from a soft yet sturdy cotton material, with a large embroidered MG motif.

Stowage bag set (all models)259-808	...£154.50
------------------------------	--------------	------------

Vinyl and double duck hoods

The hoods supplied by Moss are made on jigs matching those used by the factory, by staff that have over 100 years experience of hood manufacturing between them.

The vinyl we use is from the same supplier that originally supplied the factory, these are the closest you will get to an original hood in terms of quality, fit and appearance. Double duck material is a canvas based material which whilst being durable, is prone to fading in direct sunlight.

For full details and hood frame/fixings please refer to the Restoration section for your model. Special requirements may be available to order, please contact your nearest Moss branch.



241-905

Hoods

Special note: Originally, TA, TB, and early TC's were trimmed in black duck (a heavy single ply canvas), later TC and TD's were trimmed in the same material but with a tan duck which was a light khaki tan.

TF were originally trimmed in a multi-ply canvas material, which was light tan. As these materials are now obsolete, we use high quality double duck.

TA and TB with split window duck - black449-250	...£400.00
TA and TB with split window duck - tan449-245	...£400.00
TC with split window duck - black241-915	...£394.80
TC with split window duck - tan241-905	...£394.80
TC with single window duck - black241-950	...£395.00
TC with single window duck - tan241-970	...£395.00
TD 2 bow vinyl - black242-010	...£385.00
TD 2 bow duck - black242-050	...£395.00
TD 2 bow duck - tan242-070	...£395.00
TD 3 bow vinyl - black242-110	...£385.00
TD 3 bow duck - black242-150	...£395.00
TD 3 bow duck - tan242-170	...£395.00



242-270

TF (all models) vinyl - black242-210	...£385.00
TF (all models) duck - black242-250	...£395.00
TF (all models) duck - tan242-270	...£395.00



Classic badges

A range of quality badges for your British classic. Suitable for both grille and badge bar mounting.

- 1 BMC Drivers ClubGAC9967X£81.80
- 2 British Motor Racing Marshalls Club ..GAC9987X£72.70
- 3 British Racing and Sports Car ClubGAC9969X£22.60
- 4 BARC BrooklandsGAC9966X£22.60
- 5 Festival of BritainGAC9985X£73.60
- 6 England Union flag toothedGAC8043X£30.65
- 7 Queen Elizabeth CommonwealthGAC9968XNCA
- 8 St. ChristopherGAC9970X£67.80
- 9 RAC diamondGAC9971X£36.70
- 10 RAC round laurelGAC1028X£79.80
- 11 RAC toothedGAC8045X£30.65
- 12 UK mainland105-432£8.51
- 13 Union chequered flag (42 x 24mm)DAG000070MMM £33.60
- 14 Union flag screw fit (30 x 50mm)GAC4100£6.90
- 15 Union flag screw fit (35 x 57mm) - chrome GAC4101£13.55
- 16 Union flag stick on (pair)CRST186£4.21
- 17 Union flag magneticMM215-330£9.80
- 18 Union flag 'flying'DAG000080MMM £20.85
- 19 Union flag stick on - chromeGAC4100CR£9.62
- 20 GB letters stick on - chromeMRD1034SA£13.45
- 21 GB letters set 3 piece - chromeMRD1034A£10.70

GAC8041X



GAC8042X



Badge bar & mounting clips

- Clip badges to barGAC8041X£3.00
- Clip badges to grilleGAC8042X£5.00



451-060

Chrome badge and lamp bars

Badge bars give your classic that true period appearance.

- TD and TF models 451-060..... £68.50
(Fits between bumper and front frame extension, so it does not touch the body).
- TA and TC badge bar (less brackets) 451-070..... £56.70
- Bracket for badge bar - RH 406-310..... £16.00
- Bracket for badge bar - LH..... 406-320..... £16.00

Decals



A small selection from our range of decals available for your car, please refer to the main catalogue for a listing of the exact requirements for your model.

- 1 BMC rosette (external) CRTR208 £5.80
- BMC rosette (internal) CRTR204 £5.80
- 2 BMC Special Tuning rosette (external) CRTR207 £5.80
- BMC Special Tuning rosette (internal) CRTR207A £5.80
- Negative earth sticker..... CRST113 £1.24
- Lucas coil sticker CRST156 £2.45



High mount rack



Runyon rack

Luggage racks

Luggage racks are an extremely useful accessory, particularly when touring providing invaluable extra space and will give that true British sports car look.

High mount factory style luggage racks

- TA and TC chrome244-400£235.00
- TA and TC stainless steel244-410£236.70
- TD chrome244-500£168.50
- TD stainless steel244-510£236.70
- TF chrome244-600£235.00
- TF stainless steel244-610£236.70

TD Runyon rack

This is a reproduction of the 1950's accessory rack sold by Runyon in Los Angeles. Folding out or retracting, the rack is an easy one-handed operation.

- TD rack chrome/stainless steel243-705£136.50



HIGH CAPACITY FUEL PUMPS

Facet pumps ensure constant fuel flow and pressure even at high temperatures eliminating the problems associated with vapour lock.

The standard fuel pump may not be able to maintain adequate fuel flow and pressure at higher speeds, particularly with a tuned engine.

Facet fuel pumps are suited to all standard and modified engines fitted with carburettors.

Available in a variety of specifications to suit

the engine's fuel pressure and flow needs.

With safety in mind we recommend fitting a fuel pump inertia switch kit, so that in the event of an accident fuel delivery is automatically cut off.



See page A09 for more information



CARPET & CARPET SETS

We have a range of quality carpet sets in a variety of colours that are manufactured to high standards ensuring an excellent fit. Often using materials superior to those used for the original carpets. Where required, some of our carpet sets are moulded to follow the contours

of the floor pan as per the originals.

We also offer underfelt kits, competitively priced budget carpet sets for some models and embroidered carpet overmats.

See page A24 for more information, also see page 59 in Restoration section



Easy fit side mirror bracket

The TA, TB and TC mirror bracket was screwed to the frame, if you wanted to fit the mirror to the left side of the windscreen frame on TD and TF models, holes needed to be drilled and tapped, but now our easy fit (no drilling required) bracket is suitable for righthand or lefthand, fitting directly into the securing slot of the windscreen. Use with mirror head 407-347 to give you excellent rear visibility - even with a high mount luggage rack installed.

Easy fit side mirror bracket kit407-488£32.60
 Side mounted mirror head only407-347£146.60



Frame mounted mirrors

TA, TB and TC style. Note: Windscreen bracket will require drilling, as will the frame if you wish to mount a (LH) mirror in the TA-TC style. See Restoration section for detailed illustration.

Side mounted mirror (inc. bracket) RH407-350£215.00
 Side mounted mirror head only407-347£146.60



Replacement glass407-357£13.25
 Mounting bracket RH407-400£62.50
 Mounting bracket LH407-500£62.50
 TA and TC screw (2 required)323-090£1.50
 TD and TF screw (2 required)AJD2246£0.46



Windscreen mirrors

Give your T-series some real rear-view mirrors that are easy to install and can be removed quickly as well with no modifications to your car. The Moss R&D team have built these mirrors with available convex or flat mirrors to suit your vision comfort. Mirrors are sold individually and install to the windscreen pivot hardware using the existing wingnuts. Some minor assembly is required.

TA - TF windscreen mirror, convex RH (each) ..165-511£31.60
 TA - TF windscreen mirror, convex LH (each) ..165-512£31.60
 TA - TF windscreen mirror, flat RH (each)165-513£31.60
 TA - TF windscreen mirror, flat LH (each)165-514£31.60



Wing mirrors

Whether you fit the early Lucas type, round mirrors or the later Leyland, rectangular style, these period accessories will add that finishing touch.

Early Lucas long arm style (fixed type)

Chrome convex glass RHWM1904£12.60
 Chrome convex glass LHWM1905£12.60
 Chrome flat glass RHWM1906£12.60
 Chrome flat glass LHWM1907£12.60



Chrome flat glass (wing only) RH/LH (each) ...GAM1001 ...£33.70
 Chrome flat glass RH/LH (each)GAM1001X ..£30.60



Later 'rectangular' style (spring back type)

Chrome flat glass RH/LH (each)GAM118£34.70
 Chrome convex glass RH/LH (each)GAM117£34.70



Aluminium racing mirrors

These classic racing mirrors echo a bygone era of motorsport. Available either fully polished or satin finish with a black base, both feature a flat glass and single bolt fitting. Suitable for righthand or lefthand mounting.

Polished alloy mirror RH/LH (each)MT9314£24.00
 Satin finish alloy mirror RH/LH (each)222-355£24.00



Windtone horn set

The distinctive sounding Lucas style windtone horns are superb replicas of the horns fitted to many classic cars including MG T-Types.

1B9007/8£68.00



Classic horn

Direct replacement horn finished in luscious chrome. 105mm diameter.

MT9143£15.95



Twin air horns

Our twin air horn set includes two tuned horns, a heavy duty die cast compressor, all necessary fittings and full instructions.

GAC9978X£35.60



Altette horn

High quality Altette style horn, an exact reproduction of the TC original.

165-900£125.00



Brooklands aeroscreen

These period style aeroscreens feature a polished cast aluminium frame, chrome plated fittings, complete with mounting brackets and laminated safety glass.

- Aeroscreen and brackets (each)700896£71.50
- Aeroscreen fitting kit700896FK£9.94
- Fixing screw (each)AD608063£0.29
- Attachment bolt (each)602078£9.94



Plexiglass sun visors

Our polished and tinted plexiglass sun visors are suitable for MG TC, TD and TF. They fit on the top of the windscreen frame. (Requires drilling).

TC-TF plexiglass sun visor (each)MM240-300 ..£24.50



Wind wings

These polished clear plexiglass wind wings simply clip on to the side of the windscreen frame, so there is no need for drilling. And yes, they really do work!

TC-TF wind wing set (pair)..... 240-100.....£90.00

The M.G. Car Company Ltd.

The M.G. Car Company Ltd.

Door threshold plates

Protect your paint from scuffs and scratches and add a finishing touch of class to your MG. Our highly polished stainless steel door step threshold plates can be fitted by screws, rivets, glue, or double sided tape. Our brushed aluminium treadplates can only be screw fixed to the car. Fittings not included, supplied as a pair unless otherwise stated.

Threshold plates (The MG Car Company)451-398£40.00



DYNAMAT NOISE & HEAT INSULATION

Two steps to a quieter, cooler, better feeling great car...

Step 1 Dynamat - to deaden the noise

Apply Dynamat to all the accessible interior panels of your car. Dynamat is best for noise reduction with some heat reduction... Start with firewall/bulkheads, gearbox tunnel, front floors, doors, rear floors, roofs, wheel arches, under bonnet, boot lid.

Step 2 Dynaliner - insulates against heat

Apply Dynaliner over the top of Dynamat to reduce heat soak by up to 70%. Also helps with noise reduction.



See page A28 for more information

GAC4608



GAC4609



Auxiliary reverse & fog lamps

Many classics were not originally fitted with reverse or rear fog lamps. These universal polished stainless steel lamps measure 55mm x 110mm (2" x 4.5" approx.) and can be easily fitted, ideal for mounting under bumpers etc... Fog lamps require an illuminated switch mounted visibly on the dashboard.

- Auxiliary fog lampGAC4608 ... **£18.60**
- Auxiliary reverse lampGAC4609 ... **£18.95**
- Bulb replacement 12V 20W (each)GAC4608B ... **£3.14**



3H3058
(momentary)



GWW102X
(momentary)



RTC430A
(on/off)



GAE132G
(on/off)

General switches

A range of period looking switches for general purpose use. Use a momentary switch for starters, horns, washers, and the 1 position for auxiliary lamps.

- Push button switch momentary3H3058 ... **£13.00**
- Toggle switch momentaryGWW102X ... **£17.95**
- Toggle switch on/offRTC430A ... **£4.00**
- Pull switch on/off - white illuminationGAE132 ... **£13.00**
- Pull switch on/off - green illuminationGAE132G ... **£13.00**
- Pull switch on/off - red illuminationGAE132R ... **£13.00**
- Pull switch on/off - yellow illuminationGAE132Y ... **£13.00**
- Fuse holder inlineUKC4446 ... **£1.85**



162-705

Spot/fog lamp cover with Lucas logo

This authentic 1950-60's style, vinyl spot/fog lamp cover features the Lucas lion logo, with a clear viewing window. Suitable for 6-7" diameter lamps.

- Lucas spot/fog lamp cover, 6"black (each)162-705 ... **£51.70**
- Lucas spot/fog lamp cover, 7"black (each)162-706 ... **£51.70**



GAC4601



GAC4619

Spot & fog lamps

Give your MG a classic rally look with our range of lamps, and see where you're going at night! The spot & fog lamps can be fitted with our range of lamp bars (see page A14). All use an H3 replacement bulb GLB453 and can be fitted using the universal wiring kit GAC4027.

- Chrome 5.5" angel eye spot lamps (pair)GAC4601 ... **.NCA**
- Chrome 5.5" angel eye fog lamps (pair)GAC4602 ... **£52.80**
- Stainless steel 5" driving lamps (pair)GAC4619 ... **£39.80**



GAC4610



WPS6007

- Chrome 5.5" standard pattern spot lamps (pair) .GAC4610 ... **£44.50**
- Chrome 5.5" standard pattern fog lamps (pair) ..GAC4611 ... **£51.80**
- Replacement bulb H3GLB453 **£3.76**
- Replacement bulb H3 Xenon 30% brighter (each) GLB453X **£8.95**
- Wiring fitting kit (universal)GAC4027 ... **£11.70**

Wipac 5.5" chrome plated driving & fog lamps, with tough plastic lens covers.

- Driving lamp (pair) - WipacWPS6007 ... **£26.40**
- Fog lamp (pair) - WipacWPS6078 ... **£26.40**



BHA4399



MM162-800



MM162-700

Period style lamps

These outstanding reproductions of the original Lucas L576 units are available as either a driving lamp with a clear lens or a fog lamp with a fluted lens in either a base or back mounting. Use a back mounted fluted lamp as a works style reverse lamp.

- Driving lamp with clear lens 5.5" (each)MM162-700 ... **£75.00**
- Front fog lamp with fluted lens 5.5" (each)MM162-800 ... **£75.00**
- Back mounted lamp with fluted lens 5.5" (each) .BHA4399 ... **£75.00**
- Back mounted lamp with clear lens 5.5" (each) ..57H5322 ... **£75.00**

Don't worry if your spot or fog lamp gets damaged we stock replacement glass lamp units, so you don't have to buy the whole lamp again.

- Replacement lamp unit with fluted lens (each) ... ACG5179 ... **£33.00**
- Replacement lamp unit with clear lens (each) ..57H5015 ... **£34.00**
- Replacement bulb driving lamp (each)GLB185 **£4.32**
- Replacement bulb fog lamp (each)GLB323 **£5.15**



GAC4023Z

H4 halogen headlamp conversions

Fitting modern halogen headlamps is one of the most worthwhile safety improvements you can make to your classic. Powerful halogen bulbs combined with improved lens design, result in a superior light beam and pattern. Replacement lens units are available, please see the Restoration section.

Wipac quad optic kits

- No pilot RHD (pair)GAC4022£42.00
- No pilot LHD (pair)MGE203£50.00
- With pilot RHD (pair)GAC4023Z ..£42.00
- With pilot LHD (pair)WPS4699£54.00



GAC4023

Lucas H4 asymmetric kits

Genuine Lucas H4 asymmetric halogen lamp units, with a pilot light only.

- With pilot RHD (pair)GAC4023£90.79
- With pilot LHD (pair)LULUB802 ..£96.01

Replacement bulbs

You can choose to fit the standard 60/55W H4 bulbs, or replace them with either uprated H4 100/90W or super white xenon bulbs. The super white xenon bulbs are approximately 30% brighter than halogen.

- H4 60/55 watts (each)GLB472£4.05
- H4 100/90 watts (check regulations) (each)GLB484£6.10
- Xenon H4 60/55 watts (pair)GLB472X£8.86
- Xenon H4 60/55 watts blue tint (pair)GLB472BLU ..£8.76



Headlamp protectors

A thin, invisible layer of Lamin-X protects headlamps from stone chips and scratches, and keeps your lights looking new for years to come. Fits all 7" round headlamps. Sold as a pair. Lamp unit not included.

- Headlamp protectors (pair)162-695£15.70



506370X

LU554308

Tripod headlamps

Original equipment on early British cars. These Tripod style headlamps can be retro fitted to any suitable classic, but expect a reduction in light output. Suitable for period drives in the country on a warm summers evening. Tripod headlamps use BPF bulbs.

- Tripod headlamp assembly RHD (each)506370X£99.60
- Tripod headlamp assembly LHD (each)506372X£96.40
- Tripod lamp unit RHD (each)LU554308£66.90
- Tripod lamp unit LHD (each)LU555296£67.00
- Replacement bulb RHD (each)GLB414£3.30
- Replacement bulb LHD (each)GLB415£8.00



117-515

Headlamp relay kits

Fitting halogen headlamps puts high loads on electrical components. These kits allow easy installation of relays into the headlamp circuit allowing for the high current circuit to be run through the relay.

Fitting relays in headlamp circuits protects your wiring and reduces the resistance in the circuit allowing full power to the lamps. Kits include relays and fittings. The single relay kit can also be used for wiring spotlamps, horns and other electrical accessories.

- Headlamp relay kit 2 relay117-515£31.65
(Inc: 2 relays, pre-wired relay holders, fitted terminals, fittings & instructions).
- Relay kit 1 relayGAC4027£11.70
(Inc: 1 relay, non-assembled wiring, terminals & fittings).
- PVC tubing black pre cut metre504806£0.76

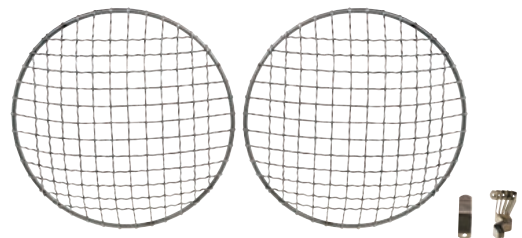

Chrome headlamp stone guards

Add some protection to your headlamps with these period chrome guards.

- Stone guards chrome clip fit (pair)GAC8000X ..£10.60



Chrome headlamp peaks

- Headlamp peaks (pair)GAC7999X ..£11.30

Car covers

Protecting your cherished classic with a car cover will help to keep the paint, hood and brightwork in the best possible condition and safe from the elements. Whether you need a cover to keep the dust off your car whilst in your garage, a lightweight cover to take to the shows and occasional use, or a cover that provides excellent weather protection for cars kept outside all year round. Moss have the perfect car cover to fit your car!



236-016

Nylon lightweight cover

Tailored specifically to fit MG T-series cars, these light weight and compact covers are perfect for overnight use. When stuffed into their attached pouch, they measure only about 12" in diameter and 6" thick, but can be easily "squished" to about half that size. Car covers must only be used on a dry car.

Nylon car cover236-016£75.76

Loose fit indoor covers

Loose fitting indoor covers made from a soft non-scratch blue poly-cotton/ polyester mix material that is Scotchguarded making it damp and drip proof. Elasticated ends for a snug fit and door zips to allow easy access. Car covers must only be used on a dry car.

Loose fit indoor coverGAC9501£105.00

Weatherproof outdoor covers

Our range of outdoor weatherproof car covers are manufactured from breathable fabrics. They feature double-stitched seams throughout, with neoprene elastic sewn into the front and rear hems. Fitted with reinforced, scratch-proof grommets for tying down. Car covers must only be used on a dry car.

Mosom Plus (2 year warranty)

Rain resistant, yet breathable, it features a multi-layer polypropylene fabric which remains soft and pliable in all weather conditions with a soft lining. Recommended for short-term outdoor use, ideal for use in outdoor covered areas such as car ports. It also works well for an upgrade indoor cover. Car covers must only be used on a dry car.

Mosom Plus car cover237-400£93.00

Ultimate outdoor cover

Ultimate car covers by Classic Additions use a specially formulated advanced nanotechnology formula which gives a unique water resistant coating ensuring long term protection for your classic. Fully waterproof, fully breathable, strong and stretchy. Manufactured in a discrete grey colour these car covers are suitable for use both indoors and outdoors. Car covers must only be used on a dry car.

Ultimate outdoor car cover, size: S2GAC95031£174.30



Wheel trims

Another popular accessory from days past were wheel embellisher trims. Fitted in seconds, these polished stainless steel trims instantly improve the appearance of steel wheels, without breaking the bank.

TD-TF wheel trim 15" (each)502160Z£50.00



Wire wheel essentials

Creating an air tight seal on a wire wheel can be somewhat difficult, making the use of inner tubes necessary and, to prevent the inner tube chaffing against the spoke nipples, the fitting of a rim band is highly recommended.

Inner tube for 15" x 155/165 tyres452-755£12.60
 Inner tube for 15" x 175/185 tyres452-765£20.90
 Inner tube (standard) for 19" x 450/500 tyres ..454-410£33.60
 Inner tube (heavy duty) for 19" x 450/500 tyres .452-785£47.20
 Rim band for 15" wheels452-750£10.60
 Rim band for 19" wheels452-760£14.65

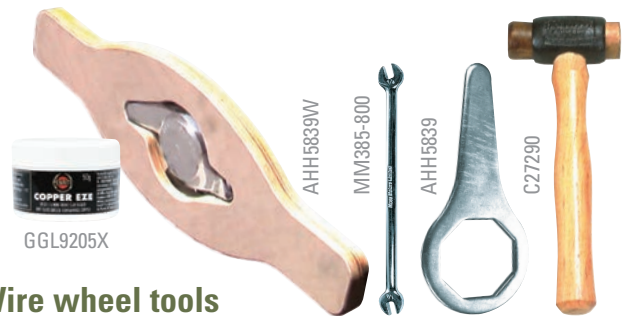

Wire wheel tools

The use of a soft-faced hammer is essential if you do not want to damage chrome plated spinners when removing or fitting centre lock wheels. We have a choice of three soft hammers. Extra long spanners are also available, providing much greater leverage for spinners and therefore easier fitting. To help keep your wire wheels looking like new we recommend you use our specialist cleaning kit. We also supply a special lubricant to help keep the splines in good condition.



Copper and hide hammerC27290£25.00
 Copper faced hammer11B5166£25.00
 Spoke adjusting spannerMM385-800 ...£9.50
 Short octagonal spannerAHH5839£5.90
 Long octagonal spannerMM386-120 ..£48.50
 Long spanner 2-earedMM386-125 ..£48.50
 Wooden wrench 2-earedAHH5839W ..£25.60
 Copper grease spline lubricant 50gGGL9205X ...£3.66
 (This unique double ended knock-off wrench, made from plywood, slips over the spinner for easy tightening and removal of spinners. Will not work with centre laced wheels.)



Centre lock spinners

All our centre lock spinners are made from the highest quality materials and are precision engineered to ensure an accurate fit. We have three styles of spinner to choose from: octagonal, two or three eared. Two and three eared spinners can be fitted with either a hammer or a spanner, octagonal spinners require a spanner.

The basic rule for threads-per-inch (TPI) is, if you have replaced your splined hubs with new ones, then you probably need 8 TPI spinners but please check before ordering.

Note: Please check local regulations for eared spinners.

- 2-eared (12 tpi) RH (plain) AHH7317 **£24.50**
- 2-eared (12 tpi) LH (plain). AHH7318 **£24.50**
- 2-eared (12 tpi) RH with MG logo AHH7317A. . . **£23.80**
- 2-eared (12 tpi) LH with MG logo. AHH7318A. . . **£23.80**
- 3-eared (12 tpi) RH (plain) AHH73173 . . . **£48.20**
- 3-eared (12 tpi) LH (plain). AHH73183 . . . **£48.20**
- Octagonal (12 tpi) RH (plain) AHH7315 **£24.00**
- Octagonal (12 tpi) LH (plain) AHH7316 **£24.00**
- Octagonal (12 tpi) RH with MG logo AHH7315A. . . **£24.00**
- Octagonal (12 tpi) LH with MG logo AHH7316A. . . **£24.00**



Wire wheel conversion kits

These kits will enhance the appearance of any TD and are identical to the original factory option for the TF. Our wire wheel conversion kits convert your disc wheeled TD or TF to wire wheels.

Each kit includes; four splined hubs, four brake drums, one spare wheel adaptor (with spinner) to convert spare wheel carrier to wire wheels, and all the studs, nuts, for an easy installation. We do not include wheels or spinners in the kits, allowing you to determine your own style.

Note: You will need 12tpi wheel spinners. For replacement components please refer to the Restoration section.

- TD & TF wire wheel conversion kit111-518**£790.00**



Tyre valve caps

These subtle and elegant nickel plated steel valve caps have an embossed MG logo.

- MG logo valve caps nickel plated (each)GAC1054X**£6.46**



454-795

WWC452

Wire wheels

An essential part of a British classic sports car's styling was the fitment of wire wheels. Whether fitted as standard or not, a set of chrome wire wheels will not only enhance the appearance of your car, but also the value.

Our wire wheel spokes and nipples are manufactured from stainless steel, with the chrome wire wheel spokes and nipples finished by chroming over the top in keeping with the rest of the wheel. They are available in different specifications; 48, 60 or 72 spokes, and a choice of classic chrome finish, or painted in wheel silver.

Depending on how you are intending to use your car, these wheels are available in standard or uprated specification. Before fitting your tyre choice, please ensure there is adequate clearance between the tyres and wheel arches.

Chrome finish wire wheels

- TA (c.1770 on) and TC 19" 48 spoke454-795**£384.40**
- TD and TF standard 15" 48 spokeWWC450**£211.00**
- TD and TF uprated 15" 60 spokeWWC452**£222.20**



WWP450

WWP452

Painted finish wire wheels

- TA (c.1770 on) and TC 19" 48 spoke454-600**£284.00**
- TD and TF standard 15" 48 spokeWWP450**£154.80**
- TD and TF uprated 15" 60 spokeWWP452**£154.20**

Please note: All wheels are sold individually unless otherwise stated.



MG hubcap

These MG hubcaps feature an attractive enamelled red medallion that sets off a steel wheel quite nicely.

- Hubcap with MG logo (each). ACH8304**£25.00**

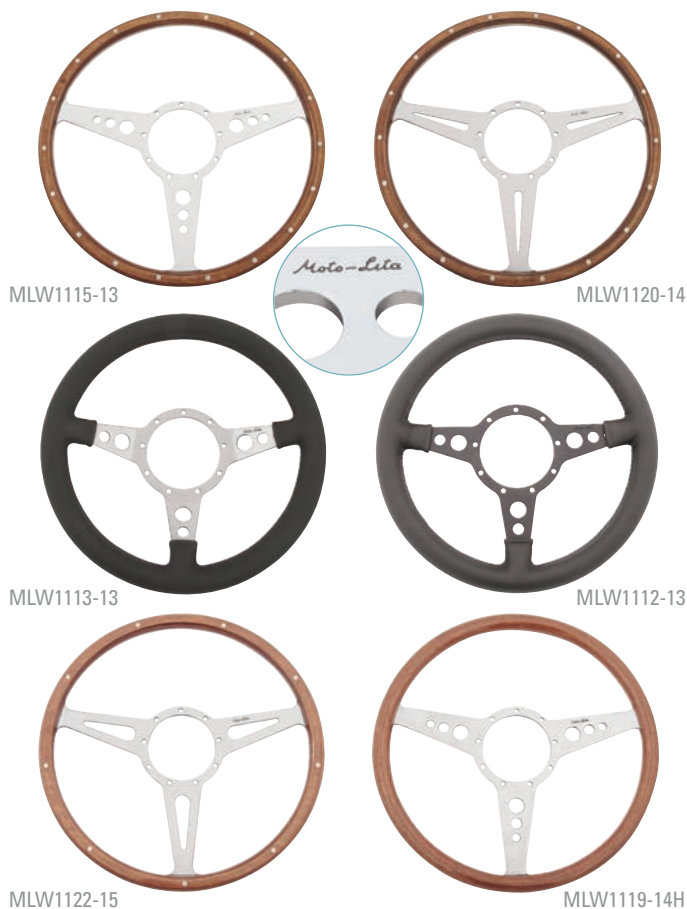

MLW1115-13

MLW1120-14

MLW1113-13

MLW1112-13

MLW1122-15

MLW1119-14H

Moto-Lita steering wheels

Moto-Lita

Moto-Lita are among the finest replacement steering wheels available. Designed to enhance the appearance of the cockpit and provide an improved feel for the driver. Available in a variety of styles, materials and sizes to suit, please see our website for the full list of options. All steering wheels listed feature drilled spokes, except where detailed.

Wood rimmed steering wheels

- MK3 flat polished spokes 13"MLW1115-13 ..£163.50
- MK3 flat polished spokes 14"MLW1115-14 ..£163.50
- MK3 flat polished spokes 15"MLW1115-15 ..£163.50
- MK3 dished polished spokes 13"MLW1116-13 ..£163.50
- MK3 dished polished spokes 14"MLW1116-14 ..£163.50
- MK3 dished polished spokes 15"MLW1116-15 ..£163.50
- MK3 flat polished spokes with thin slot 14" ..MLW1120-14 ..£163.50
- MK3 flat polished spokes with thin slot 15" ..MLW1120-15 ..£163.50
- MK3 flat polished spokes with wide slot 15" ..MLW1122-15 ..£163.50

Leather rimmed steering wheels

- MK4 flat polished spokes 12"MLW1111-12 ..£163.50
- MK4 flat polished spokes 13"MLW1111-13 ..£163.50
- MK4 flat polished spokes 14"MLW1111-14 ..£163.50
- MK4 flat polished spokes 15"MLW1111-15 ..£163.50
- MK4 flat black spokes 13"MLW1112-13 ..£163.50
- MK4 flat black spokes 14"MLW1112-14 ..£163.50
- MK4 flat black spokes 15"MLW1112-15 ..£163.50
- MK4 dished polished spokes 13"MLW1113-13 ..£163.50
- MK4 dished polished spokes 14"MLW1113-14 ..£163.50
- MK4 dished polished spokes 15"MLW1113-15 ..£163.50
- MK4 dished black spokes 13"MLW1114-13 ..£163.50
- MK4 dished black spokes 14"MLW1114-14 ..£163.50
- MK4 dished black spokes 15"MLW1114-15 ..£163.50

Mahogany rimmed steering wheels

- MK9 flat polished spokes 14"MLW1119-14H ..£226.30
- MK9 flat polished spokes 15"MLW1119-15H ..£226.30



MLW1117B8

Moto-Lita bosses

Moto-Lita

Use the appropriate boss, supplied with plastic centre cap.

- TA-TB and TC with splined columnMLW111724M ..£109.00
- TD and TFMLW1117B8 ...£97.20



Moto-Lita accessories

Moto-Lita

Where specified the boss kits are supplied with a plastic centre cap/horn push. Replacement plastic centre cap/horn pushes are available, or upgrade to a polished aluminium centre cap/horn push to enhance the look of your steering wheel, all feature a recess for a badge. Replacement ring and screw kits are also available.

- 1 Plastic centre capMLW1117X1 ..£11.15
- 2 Plastic centre cap/horn pushMLW1117X2 ..£20.85
- Polished alloy centre capMLW1117BCC ..£46.20
- 3 Polished alloy centre cap/horn pushMLW1117BHP ..£77.30
- Polished ring kitMLW1117X3 ..£11.82
- Black ring kitMLW1117X3B ..£11.51

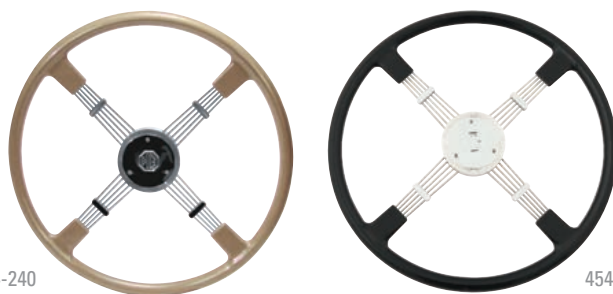

454-240

454-265

Original style steering wheels



If you wish to retain authenticity for your T-Type, then look no further than our beautifully made Brooklands and original style steering wheels. For that finishing touch why not add the Brooklands spoke badge.

Brooklands and original style steering wheels

- 4 spoke wheel, 17" (TA to (c) 2881)454-225£394.80
- 4 spoke wheel, 17" (TA (c) 2882 on, TB & TC) .454-240£343.80
- 3 spoke original wheel 16.5" (TD & TF)454-231£227.00
- 4 spoke wheel, 16.5" (TD & TF)454-265£383.40
- Brooklands spoke badge262-315£21.00

Gold Pearl Brooklands steering wheels

- 4 spoke wheel, 17" (TA (c) 2882 on, TB & TC) .454-258£343.80
- 4 spoke wheel, 16.5" (TD & TF)454-268£383.40
- Brooklands spoke badge262-315£21.00



Leather steering wheel cover

This adjustable, high quality easy to fit black cover is tailored from genuine leather to fit 16.5" rims.

- Leather steering wheel cover.....MM222-315£75.60



Tourist Trophy steering wheels and adaptor boss

Steering wheels

Designed to complement your classic, these wheels are handcrafted to high standards. Available with the choice of either a sporty leather rim or a classic riveted wood rim with a variety of spoke designs and finishes; drilled or slotted in either matt alloy or black. The frames are made from high strength aluminium.

- Leather rim black drilled spokes 14"489-040 . .£112.15
- Leather rim matt alloy drilled spokes 15"489-020 . .£112.15
- Leather rim matt alloy drilled spokes 14"489-030 . .£112.20
- Leather rim black slotted spokes 15"489-050 . .£112.15
- Laminated wood rim matt alloy drilled spokes 15" . .489-060 . .£123.35
- Laminated wood rim matt alloy drilled spokes 14" . .489-070 . .£123.35
- Laminated wood rim matt alloy slotted spokes 15" .489-080 . .£123.35
- Solid thick wood rim alloy drilled spokes 14"489-095 . .£123.50
- Solid thick wood rim alloy drilled spokes 15"489-090 . .£120.00

Adaptor boss

The boss kits include a die cast alloy boss, and a horn push with a high quality chrome and enamel badge bearing a marque emblem. The centre cap/horn push is used for all applications. If your car has the horn push on the stalk simply use as a centre cap.

- Boss kit - MG TC454-318 . .£88.20
- Boss kit - MG TD and TF454-328 . .£108.00



- The Tourist Trophy horn push is available separately to fit Moto-Lita bosses.
- Horn push with MG badge905-646 . .£18.00

Walnut veneer dash kits

- TA-TB walnut veneer dash kit . .456-885 .£247.90
- TC walnut veneer dash kit233-635 .£280.00
- TD walnut veneer dash kit RHD .233-530 .£544.00
- TD walnut veneer dash kit LHD .233-645 .£515.00



Transform the interior of your classic with our hand crafted walnut veneer kits. Made individually by skilled craftsmen, using traditional coach building methods, with modern laser technology to ensure a perfect fit. These fine quality walnut veneered dashboards are authentic for earlier TC's, but certainly look appropriate when fitted to later cars. (All TD dashes are intended to be fitted with original style glove box trim).

MG alloy gear knob

This anodised staybrite alloy gear knob featuring the MG logo is suitable for all MG models with it's unique grub screw locating system.

- MG logo alloy gear lever knobGAC0053 . .£35.60



Gear stick gaiter finisher kit

Smarten up your gear stick with this easy to fit universal gaiter finisher kit. Some gaiters may require modification to fit. (Gaiter not included).

- Chrome gaiter finishing kitGAC9540 . .£18.10

MG leather and wood gear knobs

Our varnished wood, or comfortable leather gear knobs both featuring the 'MG' emblem. Supplied with a nylon, self threading insert for easy fitting.

- MG leather gear knob (nylon insert)GAC4045 . .£12.00
- MG wooden gear knob (nylon insert)GAC4048 . .£12.50



MG grab handle

Add a touch of pre-war class in your classic with these elegant MG logo'd chrome plated handles.

- MG grab handle (each)229-101 . .£25.00

Leather seat cover kits and seat components

Rebuild and retrim your own seats with our seat kits and components. Cover kits, foams and components are all available to help you finish the job to a professional finish. See page 59 in the Restoration section for full details.



Interior trim

We offer a complete range of interior trim and hoods for your T-Type, all manufactured by our craftsmen to exacting standards.

Interior trim kits

Our complete upholstery trim kits are designed to delight the purist. See page 58 in the Restoration section for full details.

Complete leather seat assemblies

Ready to fit to your T-Type, these seat assemblies are built and trimmed by specialist craftsmen. See page 58 in the Restoration section for full details.



Carpet sets

Our ready to fit carpet sets are manufactured from original style carpet and heel mats. See page 59 in the Restoration section for full details.



Leather centre armrest

Leather armrests were a popular period accessory, they look great and improve the comfort of driver and passenger. Trimmed in leather to match our Moss interior kits, they take just minutes to install.

- TD & TF leather armrest - red245-015£210.80
- TD & TF leather armrest - beige245-035£210.80
- TD & TF leather armrest - tan245-045NCA
- TD & TF leather armrest - green245-025£210.80
- TD & TF leather armrest - black245-055£210.80



Plush embroidered carpet overmats

Custom tailored plush embroidered mats look great at a great price and fit perfectly. Edges are bound for a tidy look. Rubber nibbed backing keeps the mats in place. MG embroidered logo is 3 1/2" diameter. Supplied in black as a pair.

- TC plush carpet overmat set240-467£42.40
- TD & TF plush carpet overmat set240-751£42.40



Ultra push embroidered carpet overmats

Custom tailored for a perfect fit, these mats are made with an ultra-dense plush carpet and non-slip rubber backing. They are embroidered with a colourful 3-1/2" MG logo. Supplied in black as a pair.

- TC ultra plush carpet overmat set240-466£94.80
- TD & TF ultra plush carpet overmat set240-750£157.40

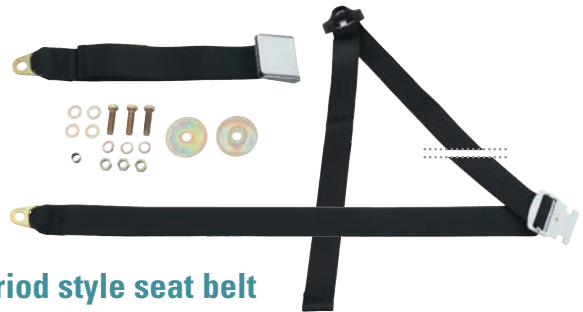

Period style seat belt

This period style seat belt features a chrome catch and fittings. Note: Not 'E' marked, requires plates TT7968 and bolt spacer kit TT7969).

- Period style seat beltAKF1646B ..£58.50



Vintage competition lap belt

The ultimate sporting accessory, ideal for early MG classics, it features a quick release buckle and includes fittings. This belt is not type approved therefore should only be used in cars that pre-date seat belt regulations.

- Vintage competition lap belt (each)MM222-211 ..£111.55

Securon seat belt and harness kits

This is our range of Securon replacement seat belts to best suit MG T-Type models. All Securon seat belt products are 'E' approved for road use. As early MG's were not originally fitted with seat belts it is essential that the belts be fitted carefully and that the correct hardware is used. Please call Moss Bradford for advice. Each kit contains suitable bolts for each mounting point, but you will need to use the reinforced nut plates (Part No: TT7968) where necessary.

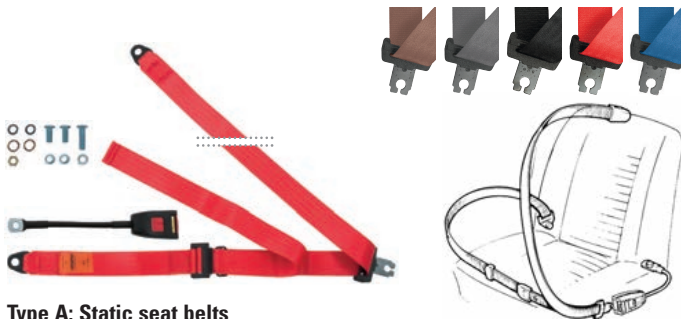

Type A: Static seat belts

This can be bolted to the upper mounting on the wheel arch, the end of the webbing is retained at the sill mounting, and the stalk is fitted to the tunnel. Once positioned the strap can be adjusted for length and fit on the over-shoulder section of the belt.

- Static seat belt 30cm stalk - blackSBS300/30£24.70
- Static seat belt 30cm stalk - redSBS300/30RED . . .£34.00
- Static seat belt 30cm stalk - beigeSBS300/30BGE . .£34.00
- Static seat belt 30cm stalk - greySBS300/30GREY .£34.00

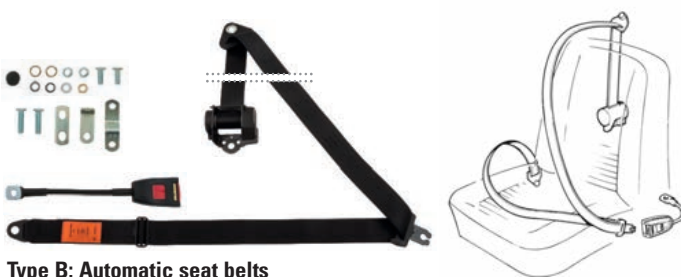

Type B: Automatic seat belts

The reel should be bolted to the lower inner side of the rear wheel arch and the guide at shoulder level on the wheel arch. The end of the webbing is retained at the sill mounting, and the stalk is fitted to the tunnel. The reel must be mounted vertically for the mechanism to operate correctly. This is the recommended inertia reel seat belt mechanism as it allows clearance for the hood frame when folded.

- Automatic/fixed seat belt 30cm stalk - black .SBS500/30£41.20
- Automatic/fixed seat belt 30cm stalk - red . .SBS500/30RED . .£49.50
- Automatic/fixed seat belt 30cm stalk - beige .SBS500/30BGE . .£49.50
- Automatic/fixed seat belt 30cm stalk - grey .SBS500/30GREY .£49.50
- Automatic/fixed seat belt 30cm stalk - blue .SBS500/30BLU . .£49.50



Seat belt extender

This can be used to safely extend the seat belt if required. It should only be bolted to the sill mounting position and then bolted to the eyelet on the end of the seat belt. It must not be used at any other mounting point. 'E' approved for road use.

- Seat belt extenderSBS227£8.34



Harness fittings

- Harness back strap adapter (pair)TT7972£6.30
(Allows harness strap to wrap around roll cage)
- Eye bolts (pair) - use with clip-in mountings .TT7967£7.48
- Bolt and spacer (pair) - use with plate mountings .TT7969£4.62
- Nut plates (pair) - reinforced for fixing bolts .TT7968£6.46



Harness kits for road use - 'E' approved

These belts feature 2" webbing with bolt through plate mountings (use with bolts TT7969). Fully adjustable lap and shoulder straps with compact buckle catch. 'E' approved for road use.

- 3 point harness kit - blackSBH628BLACK . .£34.70
- 3 point harness kit - redSBH628RED . . .£34.70
- 3 point harness kit - blueSBH628BLUE . .£34.70
- 4 point harness kit - blackSBH629BLACK . .£33.70
- 4 point harness kit - redSBH629RED . . .£33.70
- 4 point harness kit - blueSBH629BLUE . .£33.70



These belts feature 2" webbing with clip-in snap hook mountings (use with eye bolts TT7967). Fully adjustable lap and shoulder straps with load spreaders on lap belts and a compact buckle catch. 'E' approved for road use.

- 3 point harness kit - blackSBH605BLACK . .£41.50
- 3 point harness kit - redSBH605RED . . .£41.50
- 3 point harness kit - blueSBH605BLUE . .£41.50
- 4 point harness kit - blackSBH655BLACK . .£48.10
- 4 point harness kit - redSBH655RED . . .£48.10
- 4 point harness kit - blueSBH655BLUE . .£48.10



Harness kits for competition use - FIA approved

These harnesses feature 3" webbing with clip-in snap hook mountings (use with eye bolts TT7967). Fully adjustable lap and shoulder straps with a turn lever buckle. Approved for International (RAC/MSA/FIA) and National motorsport use. Not 'E' approved for road use.

- 4 point harness kit - blackSBH693BLACK .£124.24
- 4 point harness kit - redSBH693RED . .£124.24
- 4 point harness kit - blueSBH693BLUE . .£124.20
- Crotch strap kit - blackTT79662£20.65
- Crotch strap kit - redTT7966£20.65

Books, manuals & DVDs

Owners handbooks

As supplied with the car from new. These reprints can be essential for day to day maintenance.

- TD210-600 ...**£11.20**
- TF210-700 ...**£11.20**

Factory workshop manuals

Reprints of genuine factory workshop manuals packed with essential information for all aspects of vehicle maintenance and repairs.

- MG Pre-war TC210-100 ...**£57.00**
- TD-TFAKD580SC **£28.60**

T-Type instruction manuals

These factory publications were the manuals issued for TA, TB and TC models. Although reasonably comprehensive, owners would be wise to supplement these manuals with the workshop manual by W.E. Blower, part no. 210-100.

- TA and TB instruction manual ...210-480 ...**£36.40**
- MG and TC instruction manual ...210-500 ...**£20.30**

TD-TF crown wheel and pinion interchanges

This detailed step-by-step manual covers the process of converting the TD-TF rear axles to accept MGA or MG ZA/ZB crown wheel and pinions.

- Crown wheel and pinion interchange .212-350 ...**£16.75**

Haynes carburettor manual

This manual covers SU, Stromberg, Weber and Dellorto carburettors. Giving an insight into the way they operate and how to maintain and tune them, as well as detailed overhaul procedures.

- Haynes carburettor manualMGL0279 ..**£30.30**

Weber carbs: Tuning tips & techniques, by John Passini

This book is the distillation of many years experience of working with Weber carbs. The mysteries of why and how they work and the practicalities of getting the best from them. Also setting-up, fault-finding, maintenance and repair are all covered.

- Tuning tips and techniques213-431 ...**£12.20**

Tuning SU carburettors

This book looks into the basic design of the SU carburettor. It covers many areas including overhaul, tuning mixtures, jet and needle identifications and SU fuel pumps.

- Tuning SU carburettorsMGL0070 ..**£14.20**

SU workshop manual

Factory workshop manual covering both carbs and fuel pumps.

- SU workshop manualGAC1044X **£20.80**

SU needle chart

The chart identifies the correct replacement SU needle when modifications have been carried out to the engine or induction.

- SU needle chartALT9501 ..**£12.50**
- SU parts catalogueALT9524 ..**£14.70**

MG's Abingdon Factory

The MG story from the men that built the cars. It's a must-have for any MG fan. Copiously illustrated with black & white and colour photos, this 92 page soft bound book lends a personal touch to MG history.

- MG's Abingdon factoryMGL0091 ..**£15.30**

Original series book, by Anders Ditlev Clausager

This book is the definitive guide to one of Britain's best-loved sports cars, the 'Original' series books are indispensable for all owners, restorers, buyers and enthusiasts.

- Original series book - MG-TMGL0350 ..**£18.40**

SU carburettor rebuild DVD

This 2 hour 40 minute video explains how to rebuild SU carbs.

- SU carburettor rebuild DVD211-036 ...**£31.65**

Inside the Octagon DVD

Inside the Octagon. MG 1921-45, is a fascinating portrait of the pre-war MG Car Company painted by people who were there during MG's magic years. 96 minutes.

Inside the Octagon 2. MG 1946-80, chronicles the MG Car Company from 1946 to 1980. Once World War II was over, the MG Car Company hurried back into car production with the MGTC. Steel was rationed, and England needed an infusion of foreign currency.

The MG Car Company turned to the export markets, and a decades-long love affair began between America and the little British sports car. 86 minutes.

- Inside the Octagon211-061 ...**£18.40**
- Inside the Octagon 2211-062 ...**£18.40**

Original Technical Publications Heritage DVD

Original Technical Publications for heritage cars have carefully reproduced a range of DVD's giving owners and enthusiasts easy access to original publications, including parts catalogues, service manuals and owner's literature. Each OTP DVD also includes an 'online access' card containing instructions and the URL to access these publications online as well as on Tablets or handheld devices (Windows PC, Mac iOS or Android). For more details and the full range of DVD's, please see our website.

- OTP DVDHTP2002 ..**£36.70**
(MG pre-war, MG post-war saloons, MGA & MG T Type).



MG leather travel bags

These new, motorsport inspired travel bags are the perfect accessory for travelling with your MG. They feature an embossed MG logo on either side and on the zip tags, they are made from high quality supple leather and are available in a choice of either black or brown.

They are a must have item for those short breaks. Dimensions: L = 49cm H = 28cm W = 28cm (bag only).

These bags feature:

- Embossed MG logo on bag & zip tags
- Removable shoulder strap with MG logo
- Corner reinforcement
- Soft cloth storage bag
- Leather handles
- Sturdy construction
- Wear studs on base

- Travel bag MG logo blackGAC9816X ..**£208.00**
- Travel bag MG logo brownGAC9815X ..**£208.00**

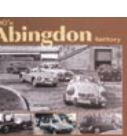
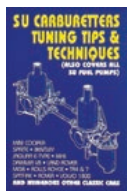
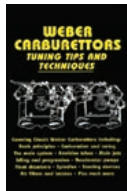
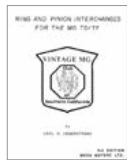
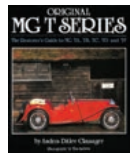



MG leather travel cases

These classically styled cases are the perfect compliment for any classic MG.

Available in brown or black leather they are a must have item for touring trips in your classic MG sports car, giving valuable extra luggage space if used with a boot rack (sold separately). Also, supplied with a smart nylon rain cover, for when the weather isn't on your side. Dimensions (approx) Width: 75cm (30"), Height: 18cm (7"), Depth: 43cm (17").

These cases feature:

- Sturdy construction
- Corner reinforcement with wear studs
- Combination locks
- Leather closing straps

- Leather travel case - brown MG logoGAC9811X ..£294.30
- Leather travel case - brown no logoGAC9812X ..£294.30
- Leather travel case - black MG logoGAC9813X ..£294.30



MG leather driving gloves

These supple leather driving gloves are available in either black or brown and feature a pressed stud with the MG marque logo. These hand-made gloves include perforated fingers for added ventilation, thin piping around the edges and a stylish exposed back for that vintage look. Supplied in pairs.

Please see our website for help with measuring to find the right size.

- Leather gloves - black with MG logo size 9GAC9850XNCA
- Leather gloves - black with MG logo size 9.5GAC9851XNCA
- Leather gloves - black with MG logo size 10GAC9852XNCA
- Leather gloves - brown with MG logo size 9GAC9850BR ..£35.00
- Leather gloves - brown with MG logo size 9.5GAC9851BR ..£35.00
- Leather gloves - brown with MG logo size 10GAC9852BRNCA



Classic flying helmet and goggles

Reproductions of the helmets and flying goggles worn by WWII pilots of the Royal Air Force. The pilot helmets are a premium grade brown leather, with a soft brown cotton lining. Featuring a forehead buckle and strap adjuster to ensure a close fit, opening ear flaps secured with a press stud fastening, and an under-chin strap, secured with a metal buckle.

The motoring helmets are a premium grade brown leather, with a soft brown cotton lining. Built-in peak to shade the sun and neck protector to stop the wind chills, with under-chin strap, secured with a metal buckle. Please see our website for help with measuring to find the right size.

The original RAF specification goggles are made with polycarbonate glass lens, grey/blue enamel frames, brown leather padding and elasticated headband.

- 1 Leather pilot helmet small - brownALCFHL/S ..£95.00
- Leather pilot helmet medium - brownALCFHL/M ..£95.00
- Leather pilot helmet large - brownALCFHL/L ..£95.00
- Leather pilot helmet X-large - brownALCFHL/XL ..£95.00
- 2 Leather motoring helmet small - brownALCFHLL/S ..£106.00
- Leather motoring helmet medium - brown ..ALCFHLL/M £106.00
- Leather motoring helmet large - brownALCFHLL/L ..£106.00
- Leather motoring helmet X-large - brown ...ALCFHLL/XL£106.00



- 3 RAF vintage goggles MK8ALCGMK8 ...£82.24



MG wallets and purses

These stylish wallets & purses are made from supple leather & high quality materials. Available in black or brown leather and embossed with your classic's marque logo, these are a must for any MG enthusiast. Offered in a variety of styles and supplied in a smart presentation box.

- 1 Purse MG logo - brownGAC9821X ..£29.30
- Wallet MG logo - brownGAC9822X ..£22.90
- 2 Wallet card holder MG logo - brownGAC9824X ..£22.90
- Purse MG logo - blackGAC9825X ..£29.30
- 3 Wallet MG logo - blackGAC9826X ..£22.90
- Wallet card holder MG logo - blackGAC9828X ..£22.90



Dynamat heat and sound insulation

Dynamat is a revolutionary range of insulation products designed to keep your classic cool and quiet.

- Non absorbent materials
- Isolates panel vibration
- Self adhesive 'peel & stick'
- Reduces road noise
- Easily cut & moulded to fit
- Reduces heat soak from engine & exhaust

Dynamat Xtreme

A highly efficient, composite material designed to reduce noise, vibration & heat soak through panel work.

- Dynamat Xtreme - speaker packGAC90511 ...£15.65
(2 sheets of 254mm x 254mm (10" x 10").
- Dynamat Xtreme - wedge packGAC90512 ...£31.50
(1 sheet of 457mm x 812mm (18" x 32").
- Dynamat Xtreme - door packGAC90513 ...£84.50
(4 sheets of 305mm x 914mm (12" x 36").
- Dynamat Xtreme - bulk packGAC90514 ...£210.80
(9 sheets of 457mm x 812mm (18" x 32").

Dynaliner

Dynaliner is an ultra-light weight, durable single layer insulation material that can be used as an alternative to traditional underfelt. It provides acoustic isolation and excellent thermal insulation.

- Dynaliner - 1/8" thickGAC90531 ...£52.80
(1 sheet of 813mm x 1372mm (32" x 54").
- Dynaliner - 1/4" thickGAC90532 ...£79.30
(1 sheet of 813mm x 1372mm (32" x 54").
- Dynaliner - 1/2" thickGAC90534 ...£105.35
(1 sheet of 813mm x 1372mm (32" x 54").

Hoodliner

Designed specifically for under bonnet insulation, Hoodliner absorbs engine noise to help keep your car quieter. The aluminised skin creates a water & oil barrier that reflects up to 97% of heat to protect the bonnet's paint.

- HoodlinerGAC90541 ...£84.50
(1 sheet of 813mm x 1372mm (32" x 54").



Workshop apron

Ideal for those messy jobs, like engine building. This apron has adjustable straps and three large pockets.

- Workshop apron with MG logoGAC9937X ...£17.00



214-320



GAC9929X

Factory dealer and service signs

High quality multi-coloured screen printed signs, perfect replicas of the originals.

- MG service sign - 12" x 16"214-320£24.00
- BMC authorised dealer sign - 18" x 27"GAC9929X ...£68.50



MG parking sign

Protect your territory and keep away unwanted and inferior cars from your parking space with these original U.S. style parking signs.

- Parking sign with MG logoGAC8032X ...£27.70



M.G.s 'through the ages' poster

Over 25 years ago, British Leyland issued this poster, now a collectors item, from Abingdon announcing the 1981 auction of the MG factory. It depicts over 30 models from 1924 to 1965 with basic specification.

- M.G.s 'through the ages' posterMGL4001X ...£9.50



Earrings with MG logo

Quality enamelled miniature earrings, with the marque logo make a perfect gift.

- Earrings with MG logoGAC9940X ...£14.40



MG bar stool

Ideal for non-darts players or when you're having a well earned 'cuppa' in the garage. 14" easy clean vinyl seats with 30" high chrome plated legs.

- Bar stool with MG logo231-800£68.00



Leather key fobs

Made in England, with a stitched leather fob and a high quality enamelled badge, featuring the various logos.

- 1 Union flagGAC4042£4.60
- 2 BMC RosetteCRSP401£4.60
- 3 MG - brown/creamGAC4037BRC£6.60
- 4 MG - black/chromeGAC4037BLC£9.83
- 5 MG - red/chromeGAC0055£8.34
- 6 MG - black/whiteGAC4037BW£4.60
- 7 MG - red/creamGAC4037RC£4.60
- 8 MG - embossed blackGAC9840X£10.40
- 9 MG - embossed tanGAC9841X£10.40



MG mug

This high quality ceramic mug has been designed for enthusiasts of this classic British Marque. Available in black with a white logo.

- MG MugGAC9458£3.55



Embroidered patches

- 1 MG Octagon - small229-500£3.47
- MG Octagon - large229-505£7.66
- 2 British LeylandGAC9960X£4.00
- 3 Union flag229-510£2.50
- 4 BMCGAC9961X£4.00



12 volt supply

This 12 volt supply or cigar lighter is a useful addition to your classic's interior. It is suitable for use as a 12V power socket for in-car accessories such as Sat Nav or simply for lighting your cigars.

- 12 volt supplyAHH7010£16.50



MG logo peak cap

These high-quality caps feature a puff embroidered MG Octagon logo. The tan and black caps have a seamed front panel that creates a firm formed appearance, while the white hat has a soft crown for a more rounded soft appearance. All three caps provide a deep low fit that allows them to stay on at high speed, and feature an adjustable Velcro closure. 100% cotton.

- Soft crown, white/navy, MG219-816£14.80
- Firm front panel, tan/green, MG219-817£14.80
- Firm front panel, black/white, MG219-818£14.80



Waterproof blanket

These waterproof blankets bring a touch of comfort to any roadside picnic. Neatly folded into a parcel, it can be easily stored and carried with its durable handle. They are manufactured from grey acrylic with a foam layer and waterproof PEVA backing. Size 51" x 70".

- Waterproof blanket, grey, Moss logo231-370£24.40
- Waterproof blanket, grey, MG logo231-375£24.40



Personal heated fleece blanket

The comfy cruise 12 volt heated travel blanket is the ideal travel companion for all weather conditions. Offering both comfort and warmth, its 42" x 58" size is large enough for two people and is perfect for warming one bench seat or two bucket seats at a time. The blanket features an 8 foot long fused cord and automatic temperature control. Made of 100% high quality polyester fleece.

- Personal heated blanket 12 volt002-842£27.60



Wine and beer glasses

Enjoy your favourite drink from these glasses bearing the MG logo and 'Safety Fast' script. Perfect for those show picnics and summer evening barbecues.

- Pint glass set MG (set of 4)230-931£15.25
- Wine glass set MG (set of 4)GAC1056X£26.50



Vintage screw jack

Identical to the jack specified as original equipment on many vintage cars.

Safety Note; Once the car has been jacked-up, It is advisable to support the vehicle properly before you start working beneath it.

Screw type jack with handleAHH5124K **£106.60**



385-910

Tool rolls

Vintage style tool roll

This heavy duty canvas tool roll features top & bottom tool retaining flaps, adjustable leather tool loops and buckle strap

Vintage style tool roll385-910 **£49.50**



MM647-100

Tool rolls

We offer two styles of small tool roll ideal for your mobile tool kit. Both manufactured from vinyl backed hessian material, with stitched tool pouches and a tie strap. We also offer a larger tool roll manufactured from hardura.

Tool roll small 8 pouchesACG5247 **£33.60**

Tool roll small 9 pouches & flapMM647-100 **£36.70**

Tool roll large 8 pouchesGAC8418X **£47.20**



AHA5506

Jack bags

A jack bag keeps your jack and any associated tools together, also helping to prevent damage to the boot area panel work. Manufactured from hardura and featuring a folding flap and tie straps. Suit most common sizes of scissor jacks.

Jack bag side flap with tie strapsAHA5506 **£35.00**

Jack bag end flap with bucklesAHH6540 **£27.80**



231-160

Comes as a self-build kit.

Die cast metal MG model kits

Ever wanted to replicate your classic in 1/24 scale? Well now you can with these die cast metal MG-T Model Kits. These kits include precision cast metal parts and full assembly instructions which should take less time to build than your actual car! The models can be glued or soldered together and make a fine ornament for your home or garage. Paints not included.

Model kit TC231-280 **£83.45**

Model kit TD231-160 **£61.25**

Model kit TF231-260 **£63.50**



Union flag

Made from lightweight polyester complete with metal grommets on the hoist. Ideal for those continental get-togethers.

Union flagGAC9939X **£19.90**



Seat belt shoulder pad

Easily installed, these shoulder pads add both comfort and flair. Sold as a pair.

Seat belt shoulder pad - red MG logo231-300 **£21.00**



BMC service & sales T-shirt

The "retro style" is in fashion so show off your BMC loyalties with this 100% cotton t-shirt that features a logo based on the vintage dealership sign.

BMC Sales & Service, navy, T shirt - medium ..013-705 **£13.60**

BMC Sales & Service, navy, T shirt - large013-706 **£13.60**

BMC Sales & Service, navy, T shirt - X-large ..013-707 **£13.60**

BMC Sales & Service, navy, T shirt - XX-large ..013-708 **£13.60**

Ordering Information

Notification of prices

Due to the volatility of world markets and currency fluctuations the prices in this catalogue are subject to change. Moss make every attempt to keep prices competitive and stable, however in common with all other suppliers in our industry, we reserve the right to alter these prices without prior notice.

For the latest prices, please visit our website www.moss-europe.co.uk. All prices are per unit (unless otherwise stated) and include (UK) VAT at 20% (where applicable) and are correct at the time of going to print. Postage and packaging is not included. E&OE. Where the price is replaced with NCA this part is Not Currently Available. Please visit our website (moss-europe.co.uk) or call our sales staff for the latest availability information or to enquire if we can offer an alternative part.

Product supersessions

Moss Europe's policy is to detail the most up to date part information in our catalogues. Where possible parts are kept to original specification. However, in some instances we have to supersede to the most viable alternative product to maintain supply and keep cars on the road. Every effort is made to ensure high quality products.

UK ordering

We accept orders by mail, telephone, e-mail, fax and on-line at www.moss-europe.co.uk. If you have the opportunity, we invite you to visit one of our branches. Remember, supplying details of your car, (i.e. engine, commission or Vehicle Identification Number (VIN) LHD or RHD, year of manufacture and any modifications) saves time and helps us to help you. Please inform us of your customer number, as this will speed up the processing of your order.

Overseas ordering

We accept orders by mail, telephone, e-mail, fax and on-line at www.moss-europe.co.uk. If you visit the U.K. please come and visit one of our branches. When ordering, please ensure that you enclose full details of your name, address and customer number, plus details of your car (i.e. engine, commission or Vehicle Identification Number (VIN) LHD or RHD, year of manufacture and any modifications).

Please note: Overseas orders are often subject to local import duties, taxes and Customs clearance, which will need to be paid for at the point of entry. These charges are NOT included in the price of the goods or delivery prices. All relevant Customs forms and documentation needed to ensure the order arrives with the minimum of delay, will be included with your shipment. If you have any special requirements, please contact us to discuss them. Delivery charges are dependent upon the size and weight of the shipment. If a quotation is required prior to placing an order, please contact the export department at your chosen branch and they will be pleased to supply a full quotation.

Parts back-order system

A back-order system is used when a part is not in stock at the time of ordering. If the item is expected to become available within 6 months, then it will be put on back-order, unless the customer instructs us otherwise. When we have the parts in stock, the back-order will be processed automatically and the item will be dispatched to the customer. If the particular part becomes No Longer Available (NLA) or does not become available within 6 months the back-order will be cancelled. If you are unsure when you placed a back-order contact your local branch.

Dispatch & delivery methods

Orders for delivery in the UK may be dispatched by regular post for small/lightweight items, larger items may be dispatched via a courier. Please call us for the best delivery option for your order and the latest delivery prices. For delivery outside the UK we offer the following services.

- **Economy delivery (by road):** 2 to 5 days (approximately).
- **Express delivery (by air):** 1 to 2 days (Guaranteed) - next day service to most countries.
- **For small and low value orders we also use airmail.**

For these services, please ask for prices and the best delivery option when you place your order. Most deliveries (except airmail) are 'trackable', (inc: e-mail updates and internet access for selected carriers). Please remember, all carriage charges are dependent on weight band, volume, destination and delivery time. If a quotation is required prior to placing your order, please contact a member of the sales department. Alternatively, you can arrange your own delivery and dispatch.

Windscreen delivery information

We always suggest that windscreens should be collected from one of our branches to ensure you are able to transport your glass with the utmost of care. However, we understand that this is not always possible.

To minimise the possibility of damage to the windscreen in the shipping process, it is now Moss Europe's policy to ship windscreens packed in a specially designed heavy duty 'Tri-Wall' cardboard box. The price of this box is £35.00 (inc VAT), non-refundable and is included in the price of the product. The crate's dimensions will also increase shipping costs, particularly in EU countries. The crate dimensions are 150cm x 33cm x 74cm. The maximum volumetric weight is 92kgs. For more information please contact your nearest Moss branch.

Hazardous goods delivery information

At the time of going to print, Moss Europe Ltd conforms to international shipping regulations regarding packaging and transportation of Hazardous Goods by road and sea freight (only). Due to these international shipping regulations and licencing rules all goods deemed as Hazardous are currently available for shipping to the UK and Europe only. If you place an order containing Hazardous goods and your shipping address is not in the UK or Europe, we will not be able to ship this item to you. Please contact your local branch or visit our website moss-europe.co.uk for the latest delivery information of Hazardous goods.

Quotations & payment methods

We will be pleased to provide a full parts quotation detailing price, availability and relevant shipping costs. Payment may be made by cash, personal cheque (to the card guarantee limit), Certified Bank Draft, Sterling Travellers Cheques and credit or debit card including: Mastercard, Visa, Delta. If you intend to make payment by Cheque or Bankers Draft when

using our fast mail-order parts service, please confirm parts availability and carriage charges. We can accept payments using PayPal for website, email and phone orders.

Value added tax (VAT)

Value Added Tax (VAT) at the current rate will be levied on all orders being dispatched to all countries within the European Community. EU countries may be charged at their local VAT rate, please contact us or see website for details. VAT is not charged on goods dispatched to countries outside of the EU. However, such orders are often subject to local import duty, taxes and Customs clearance, which MUST be paid by you at the port of entry. Such charges are not included in the cost of the goods or delivery prices.

Exchange units

We are able to offer a full rebuild service on numerous major components in our product range. We offer this service as an alternative to direct replacement parts, or when a brand new item is no longer available. However, the continuity of this exchange scheme needs the understanding and co-operation of our customers in relation to several important points: It is important to remember that "rebuild" does not mean "brand new". Rebuilding a unit involves stripping, cleaning, inspecting and re-assembling the unit. During this process, parts showing signs of wear will either be completely replaced or suitably renovated. However, it is not always feasible for major sub-components to be replaced with brand new ones, for example, an exchange engine will not have a new block. Due to the nature of certain product lines, some items can only be offered on a "one for one" exchange basis. This effectively means that you must offer us a viable unit before we can release a fully rebuilt item from our stock. In some instances we can only carry out reconditioning of your own unit. Our staff will inform you if this is the case.

All exchange units are subject to a surcharge. This surcharge serves two purposes; firstly, it acts as an incentive for you to return your old unit, and secondly it provides us with financial cover if your returned unit proves unsuitable for exchange purposes.

Whether or not your returned unit is suitable for exchange purposes cannot be ascertained until it is made available to us for inspection. As a general rule, suitable for exchange basically excludes any items that are beyond reasonable repair (e.g. crankcases pierced by a connecting rod) or units irrevocably damaged. We are also unable to accept units unless they are returned in whole, complete form (i.e. differential units which are returned partly stripped with no bearings and all the shims missing are not generally accepted), nor do we accept a "box of bits".

Surcharges will only be refunded once our core department has passed the item as serviceable. Under no circumstances can any exchange unit be shipped overseas until we receive your original unit. We have predetermined prices for our exchange units based on our experience of repair costs for a gearbox, axle or engine. Occasionally, however, the damage to the unit is so great that we will contact you before beginning work on your unit to advise you of any additional cost that may be incurred during the rebuild of the unit. We can return the unit (at your cost) if this proves unacceptable.

'Old unit' returns

Exchange items including reconditioned engines are subject to a surcharge that is refunded when a rebuildable unit (core) is returned. When you receive the rebuilt unit, attached to it will be a Core Return Authorisation Tag. This tag must be removed from the rebuilt unit and attached to the returned core in order to receive credit. Cores must be returned within 90 days of purchase in the original box, carton or engine cradle supplied with the rebuilt unit. Cores must be shipped clean and empty of fluids. Cores must be complete, assembled and rebuildable to receive credit or refund. You must pay all shipping charges for the return of the core and these charges are not refundable.

Warranty

All parts are warranted against defects in materials and workmanship for a period of twelve (12) months from the date of purchase. The warranty does not cover failure resulting from incorrect installation or misuse; failure during any competition, motorsports or track events; failure of any, or caused by any, related component. The warranty does not cover labour charges, nor will a warranty settlement be greater than the cost of the original component. Should you need to make a warranty claim, please contact us immediately at the branch of purchase. We will then advise you as to the best course of action. With all warranty claims a copy of the original purchase invoice must be produced.

Warranty returns

Parts that fail in use may be returned for 12 months from the date of purchase. Returns must be accompanied by the original invoice - no warranty claims will be paid without a copy of the original invoice. Return freight will be reimbursed. Electrical parts returned for warranty will be tested and if found functional, no return credit will be given and the part will be returned. Reimbursement is made by the original payment method. Complete the return form included in each order, pack the items securely and use the shipping return label supplied.

Non-warranty returns

All uninstalled parts, in their original packaging may be returned within 90 days for any reason. A copy of the original invoice or the picking label (which is generally attached to the original packaging) must accompany the return. Return freight is paid by the customer. If the return is due to our error, the return freight will be reimbursed. Parts returned outside of this policy or in non-resalable condition may not be accepted or may be assessed a 15% handling fee. Reimbursement is made by the original payment method. Complete the return form included in each order, pack the items securely and use the shipping return label supplied.

Customer service

We value your custom and wish to ensure that you receive the very best service. Every effort will be made to provide you with Quality Parts and Expertise in a relaxed, helpful and friendly manner. Should you consider the service you receive from us to be unsatisfactory, or you have any problems with the part(s) purchased, please advise a member of the sales team at the originating branch. If the matter is not resolved to your satisfaction, please e-mail our Customer Services Department at customerservices@moss-europe.co.uk or write to: **Customer Services, Moss Europe Ltd Unit 16, Hampton Business Park, Bolney Way, Feltham TW13 6DB England.** *We will do our very best to resolve the issue.*

British Motor Heritage

Moss Europe Ltd is a British Motor Heritage approved specialist. Our agreement with British Motor Heritage allows us the use of marque logos and some of the artwork contained within this catalogue.



'T' Type Production Data and General Information

TA

Production Period: June 1936 - April 1939
Car Numbers: TA0251 - TA3253

Abingdon Production: At this time Abingdon was virtually no more than an assembly plant and all items such as chassis, engines, transmissions were shipped into the plant from other Nuffield owned factories.

TB

Production Period: May 1939 - September 1939
Car Numbers: TB0251 - TB0629

Autumn 1938: Leonard Lord, rationalising parts usage in Morris production, announced the new XPJM engine from Morris Engines. The 1250cc XPAG unit was adapted from this model replacing the overhead camshaft Wolseley units originally destined for the TA.

TC

Production Period: November 1945 - November 1949
Car Numbers: TC0251* - TC10252

1945	17th September - 21st December	TC0251 - TC0351
1946	17th January - 31st December	TC0352 - TC2051
1947	17th January - 31st December	TC2052 - TC4411
1948	5th January - 24th December	TC4412 - TC7502
1949	5th January - 29th November	TC7503 - TC10251

February 1945

Cecil Kimber, 56 years old, was killed in a railway accident just near Kings Cross Station, London. He had been manager of MG from 1923 until 1941 when he left after a major row with Miles Thomas, then managing director of Nuffield Group. Kimber had been the inspiration behind the first special bodied Morris bull-nose cars carrying the MG badge.

Purchase Tax

This new tax was introduced following the war to fund the rebuilding of Britain, pushing the cost of new MG's up to high levels.

Export Drive Begins

In 1947 Abingdon officially began exporting MG's to the USA. All early exports to the US were RHD because of the difficulties of conversion. Only 20% of the total TC production was officially exported to the USA. *TC0251 appears to have been the prototype model TC and is often not counted in TC production figures.

TD-1

Production Period: November 1949 - August 1951
Car Numbers: TD0251 - TD9158

1949	10th November - 20th November	TD0251 - TD0348
1950	2nd January - 22nd December	TD0349 - TD5169
1951	1st January - December	TD5170 - TD12577

TD-2

Production Period: August 1951 - September 1953
Car Numbers: TD9159 - TD29915

1952	1st January - 31st December	TD12578 - TD23634
1953	1st January - 17th August	TD23635 - TD29915

TD-2 & TD MkII

The TD-2 was the standard production car from September 1951 through 1953 and should not be confused with the TD MkII which had been developed and sold in limited numbers. The MkII was really intended for competition use only. The rare TD MkII was fitted with large valves in the cylinder head, 1 1/2" carburettors, twin fuel pumps and additional Andrex friction dampers.

Chassis Numbers

Traditionally, all new MG models began with the chassis number 251. Abingdon 251 was in fact the factory's telephone number. Once taken over by BMC this traditional and delightful practice was stopped, perhaps in an effort to prove to Abingdon that they were now no more than a subsidiary of the mighty BMC empire. In 1955, proving otherwise George Eyston and Ken Miles, using the new MG XPEG 1466cc TF engine, took eight endurance records in Utah. It proved to the world that MG, though now a poor relation of BMC, still had what it took when it came to competing against all-comers.

TF

Production Period: October 1953 - May 1955
Car Numbers: TF0501 - TF10100

1953	17th September - 31st December	TF0501 - TF2177
1954	4th January - 30th December	TF2178 - TF8643
1955	4th January - 4th April	TF8644 - TF10100

Once Again

As was the case with the TD, the new TF was put together in just 2 weeks, this time by John Thornley and Syd Enever, following their failed attempt to talk Leonard Lord into providing funding for a replacement TD. Soon after, following widespread criticism of the new TF, funding was provided to produce the MGA.

November 1954

Conversion of the XPAG to XPEG engine: Fitting of the 1466cc XPEG engine occurred in small batches during November 1954. The XPEG unit was initially sold in North America only. The British public, although hearing rumours of the larger engine's production, had to be content with buying the old model 1250cc XPAG engine until production stopped.

TF6501 - TF6650	(1466cc)
TF6651 - TF6750	(1250cc)
TF6751 - TF6850	(1466cc)
TF6851 - TF6950	(1250cc)
TF6951 - TF10100	(1466cc)

A Brief History Of The Development Of The 'T' Type.

H.N. Charles develops new TA at Cowley guided by Cecil Kimber. (Authorised & developed in 1935-36).

Chassis: Under slung style copied from the 1920's French design (first used on C type Montlhery Midgets of 1931).

Engine: Based on Morris's 1292cc side valve unit, cork faced wet clutch, four-speed gearbox without synchro.

Suspension: Half elliptic springs front and rear with Luvax shock absorbers.

Brakes: First Midget fitted with hydraulic brakes.

August 1938: Announcement of the Tickford Drop-Head Coupé with folding hood.

TB introduced May 1939 using TA body and chassis but with new XPAG engine, dry plate clutch, revised gearbox (with synchromesh on 2nd gear). 5:12:1 rear axle. Only 379 models were produced before onset of World War II. Abingdon turned its hand to war production.

November 1945 introduction of the TC. War production ceases and Abingdon returns to motor vehicle production. The body shell was based on pre war TA/TB model, but widened by 4" (similar to Tickford TA shell). Single 12-volt battery introduced. Luvax/Girling front shock absorbers fitted.

Exporting to the United States of America: TC7380 first USA official export model built in December 1948.

First TD mock up produced by Syd Enever and Alec Hounslow in two weeks during 1949. It was cobbled together using a YA type chassis (cut and shut) and heavily hammered TC body. Engine as per TC but gearbox used a new gearbox extension. Front Suspension altered to coil spring (a la YA, Morris 10 series M, MGA and MGB). Hypoid rear axle fitted. Rack and pinion replaced steering box. Pressed steel wheels fitted to take account of new suspension geometry. Two leading shoe front brakes installed. First batch of TD's was followed by the inclusion of tubular steel scuttle support to counter scuttle shake. Body extensively altered but similar in appearance to TC. Bumpers fitted.

Summer 1950, perforated wheels fitted as standard.

TD MkII introduced (August 1951).

Improved XPAG engine installed (engine XPAG/TD/9408 onwards). 8" clutch fitted with new flywheel and gearbox housing.

Engine XPAG/TD/14948 increased capacity sump pan fitted.

New style round tail lamps fitted from chassis number TD21303.

Rod control clutch linkage fitted from chassis TD22251 on.

Centre mounted wiper motor fitted at chassis number TD22315. (Fitted as safety feature).

From engine XPAG/TD/24116 new camshaft fitted to improve power.

The TF 1250 ran on the last modified TD chassis using TD running gear and components, but with raised gearbox final drive. Centre lock wire wheels became an option (theoretically this had become possible for the TD so long as the new TF-style hub and fittings were used). Perforated disc wheels were standard. New style grille accompanied altered bodywork. Sealed in headlamps completed the newer shape. Individual seats were finally adopted. Wiper motor hidden under fascia with scuttle-mounted wipers.

XPEG engine introduced gradually in November 1954 (see notes below # and conversion chart left *).

The new XPEG engine: First introduced at chassis number TF6501 in November 1954. The new XPEG engine had been designed, during the early fifties, by Morris Engines Branch. Boring out the XPAG engine was considered impossible as it had already been increased in capacity from 1140cc and the cooling system would be unable to dissipate heat from the block quickly enough if further change were made. A revolutionary new approach was used to redevelop the entire cylinder block and alter the cylinder head. Once designed, sufficient stocks of the engine were built up before being introduced to the Abingdon assembly lines in batches during November 1954.

Late TF (chassis number TF10100 engine XPEG/TF/3940) produced on 4th April 1955.

Catalogue Contents

Ordering informationPage 01
 Production DataPage 02
 Identifying Your CarPage 02
 Catalogue Contents & Location Of Serial Numbers .Page 03
 Parts IndexPages 04 & 05

Engines & Components (See also Clutch)

Engine Mountings & StabilisersPage 06
 JR Supercharger KitPage 06
 External EnginePage 06
 Cylinder Block Fittings & Cylinder HeadPage 06
 Oil Pump, Sump & Oil FilterPage 06
 Timing Cover & Engine PlatesPage 06
 Inlet & Exhaust ManifoldsPage 06
 Internal EnginePage 08
 Crankshaft, Con Rods, Pistons & Cylinder Liners .Page 08
 Rocker Shaft, Valve Springs & ValvesPage 08
 Camshaft & Timing GearPage 08
 Engine Gasket SetsPage 08

Cooling System

Radiator & FittingsPage 10
 Oil Cooler KitsPage 10
 Water Pump, Fan, Thermostat & HosesPage 11

Clutch System

LHD to RHD Steering Conversion Parts, TD & TF .Page 12
 Clutch Drive Components & FlywheelPage 12
 Pedal Fittings, Operating Shaft, & CablesPage 12

Gearbox

Gearbox Components & Propshaft, TB & TCPage 14
 Gearbox Components & Propshaft, TD & TFPage 16

Fuel System

(For Inlet Manifold See 'External Engine')
 Carburettors & Components, (All Models)Page 18
 Air CleanersPage 19
 Fuel Pump & Control CablesPage 19
 Fuel Tank, Pipes & FittingsPage 20

Exhaust System

(For Exhaust Manifold See 'External Engine')
 Exhaust System, (All Models)Page 20

Road Wheels & Tools

Road Wheels, (Standard)Page 21
 Wire Wheel Conversion Kit, TD & TFPage 21
 Roadside Tools & EquipmentPage 21

Brake System

(For TD & TF Brake Drum Illustration See 'Front Suspension')
 Brake System, (Handbrake & Hydraulic), TA-TB & TC .Page 22
 Brake System, (Handbrake & Hydraulic), TD & TF .Page 23

Steering

TA-TB & TC, (Inc. Tompkins Steering Kit)Page 24
 TD & TFPage 25
 Steering Conversion Parts, (LHD to RHD), TD & TF .Page 25

Front Suspension

TA-TB & TCPage 26
 TD & TFPage 27

Rear Suspension

TA-TB & TCPage 28
 TD & TFPage 28

Rear Axle & Propshaft

TA-TB & TCPage 30
 TD & TFPage 31

Electrical System

Dynamo & FittingsPage 32
 Starter Motor & FittingsPage 32
 Starting HandlePage 32
 Battery, Fittings, Cables & SwitchesPage 33
 Wiring Harness, (Looms)Page 33
 Ignition SystemPage 34
 Regulators & FusesPage 35
 Windscreen Wiper Motor, Arms & BladesPage 35
 Horns & FittingsPage 35
 Headlamps & FittingsPage 36
 Front Fog Lamps & FittingsPage 36
 Front Side LampsPage 37
 Rear LampsPage 37

Dashboard Components

Dashboard, Switches, Instruments & CablesPage 39

Body Panels, Body Tubs & Timbers

TA & TBPage 40
 TCPage 42
 TDPage 44
 TFPage 46

Body Rubbers

TA-TB & TCPage 49
 TDPage 50
 TFPage 51

Chrome

(Exterior Body Fittings & Chrome Trim)
 TA-TB & TCPage 52
 TDPage 54
 TFPage 56

Interior

Interior Trim Kits, (all models)Page 58
 Seat Assemblies, (all models)Page 58
 Squab & Cushion Sets, (all models)Page 59
 Carpets, Mats & Boots, (all models)Page 59

Exterior

Hood, Frames & Rails, (all models)Page 60
 Tonneau Covers & fittings, (all models)Page 60
 Side Screen & Frames, (all models)Page 61
 Side Screen Stowage Bag, (all models)Page 61

Miscellaneous

Chassis Frame FittingsPage 48
 Penrite Oil Lubrication ChartPage 13
 General Hardware & FixingsPages 62-64
 Body Paints & CodesPage 67

Location of Serial Numbers

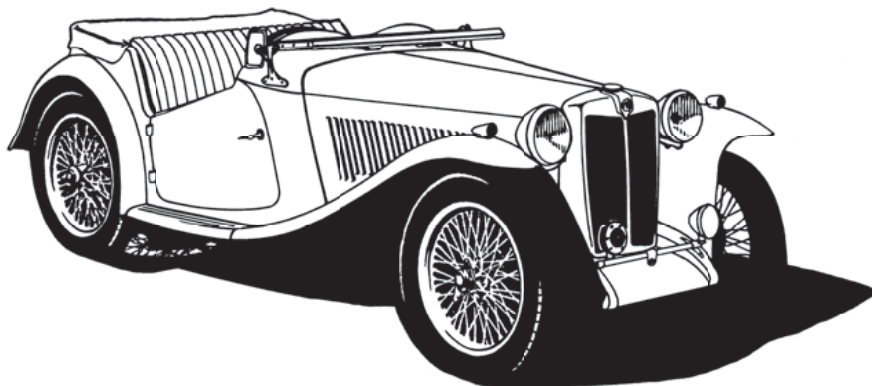
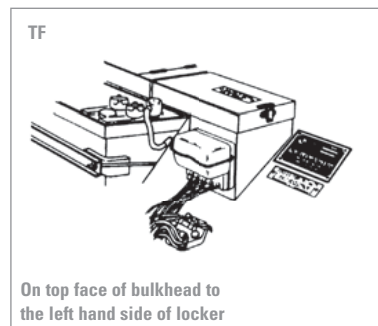
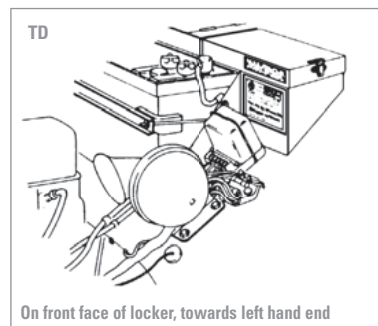
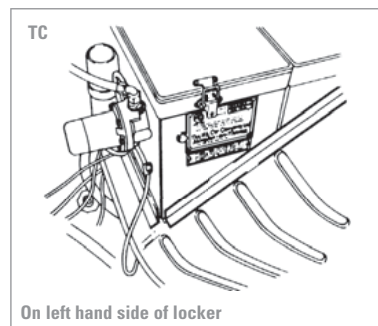
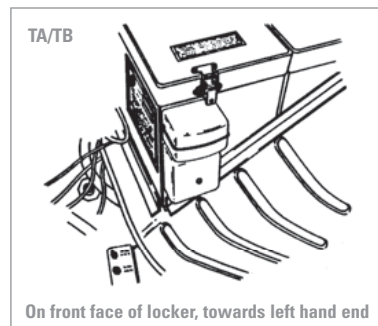

Please note: In most circumstances Moss can supply both an OE (Original Equipment) part or an Aftermarket part. The Aftermarket part offers a high quality part but usually at a reduced price and in certain circumstances replaces the OE part when no longer available. The Aftermarket part is indicated by a letter "Z" at the end of the part number.

Note: These pages list only the major items in each area, such as body work, electrical and brake components. In many cases minor fittings, clamps and linkages etc, are not shown.

A

Aero Screen, Brooklands	Page 53
Air Cleaner Manifold	Page 19
Air Cleaners	Page 19
Ammeter	Page 39
Axle Shaft, TA-TB & TC	Page 30
Axle Shaft, TD & TF	Page 31

B

Badge Bar, TA-TB & TC	Page 53
Badge Bar, TD & TF	Page 54
Battery	Page 33
Battery Fittings	Page 33
Battery Tray Liner	Page 33
Bearings, Con-Rod, (Big End)	Page 08
Bearings, Camshaft	Page 08
Bearings, Main	Page 08
Body Panels, TA & TB	Page 40
Body Panels, TC	Page 42
Body Panels, TD	Page 44
Body Panels, TF	Page 46
Body Timbers, TA & TB	Page 41
Body Timbers, TC	Page 43
Body Timbers, TD	Page 45
Body Timbers, TF	Page 47
Body Tub Steelwork, TA & TB	Page 40
Body Tub Steelwork, TC	Page 42
Body Tub Steelwork, TD	Page 44
Body Tub Steelwork, TF	Page 46
Body Tub, TA & TB	Page 41
Body Tub, TC	Page 43
Body Tub, TD	Page 45
Body Tub, TF	Page 47
Bolts, (General Fasteners)	Page 62
Books	Accessories
Boyce Moto Meter & Cap, TC & TD	Acc.
Brake Hoses, TA-TB & TC	Page 22
Brake Hoses, TD & TF	Page 23
Brake Light Switch, TA-TB & TC	Page 22
Brake Light Switch, TD & TF	Page 23
Brake Master Cylinder, TA-TB & TC	Page 22
Brake Master Cylinder, TD & TF	Page 23
Brake Pipe Set, TA-TB & TC	Page 22
Brake Pipe Set, TD & TF	Page 23
Brake Shoe Set, TA-TB & TC	Page 22
Brake Shoe Set, TD & TF	Page 23
Brake System, TA-TB & TC	Page 22
Brake System, TD & TF	Page 23
Brooklands Aero Screen	Page 53
Brooklands Steering Wheel	Page 29 & Acc.
Brush Set, Dynamo	Page 32
Brush Set, Starter	Page 32
Bulbs	See Lamps
Bumpers, TD	Page 54
Bumpers, TF	Page 57

C

Camshaft	Page 08
Camshaft Bearings	Page 08
Car Covers	Accessories
Carburettors & Fittings	Page 18
Carburettor Gasket Set	Page 18
Carburettor Rebuild Kits	Page 18
Carburettor SU Manual	Accessories
Carpet Hardware	Page 59
Carpet Sets	Page 59
Chassis/Engine Plates, TA-TB & TC	Page 52
Chassis/Engine Plates, TD	Page 54
Chassis/Engine Plates, TF	Page 56
Chassis Frame Fittings, TA-TB & TC	Page 48
Chassis Frame Fittings, TD & TF	Page 48
Choke Cables	Pages 19 & 38
Chrome Exterior, TA-TB & TC	Page 52
Chrome Exterior, TD	Page 54
Chrome Exterior, TF	Page 56
Cluster Panel	Page 06

Clutch	Page 12
Clutch Cover	Page 12
Clutch Lever Arm	Page 12
Clutch Linkages	Page 12
Clutch Pedal	Page 12
Clutch Plate	Page 12
Clutch Release Bearing	Page 12
Coil, Ignition	Page 34 & Accessories
Colour Chart, Interior trim	Page IBC
Condenser	Page 34
Contact Breakers	Page 34
Conversion Of LHD To RHD	Page 25
Crankshaft	Page 08
Crankshaft Bearings	Page 08
Crown Wheel & Pinion, TA-TB & TC	Page 30
Crown Wheel & Pinion, TD & TF	Page 31
Cushion/Squab Sets	Page 59
Cylinder Head/Information	Pages 06 & 07
Cylinder Liners	Page 08

D

Damper Assembly, Carbs	Page 18
Dash Panels	Page 38
Dashboards	Page 38
Decals, (Instruments)	Page 38
Differential Gear, TA-TB & TC	Page 30
Differential Gear, TD & TF	Page 31
Dip Switch, Floor Mounted	Page 35
Distributor	Page 34
Distributor Cap	Page 34
Distributor Components	Page 34
Door Hinges, TA & TB	Page 40
Door Hinges, TC	Page 42
Door Hinges, TD	Page 44
Door Hinges, TF	Page 46
Door Locks, TA, TB & TC	Page 52
Door Locks, TD	Page 54
Door Locks, TF	Page 56
Driving Lamp	Accessories
Dynamo	Page 32

E

Engine Spray Paint	Page IBC
Engine, History	Page 06
Engine, External Components	Page 06
Engine, Internal Components	Page 08
Engine/Chassis Plates, TA-TB & TC	Page 52
Engine/Chassis Plates, TD	Page 54
Engine/Chassis Plates, TF	Page 56
Engine Mountings/Stabilisers	Page 06
Exhaust System, TA-TB & TC	Page 20
Exhaust System, TD & TF	Page 20

F

Fan Belt	Page 11
Fan Blades, Cooling	Page 11
Float Bowls, (Carbs)	Page 18
Fog Lamp Switch	Page 38
Fog Lamps	Pages 36 & 52 & Acc.
Fuel Cap, TA-TB & TC	Page 52
Fuel Cap, TD	Page 54
Fuel Cap, TF	Page 56
Fuel Pipes	Page 20
Fuel Pump & Components	Page 20
Fuel Reserve Tap	Page 19
Fuel Tank Float Unit	Page 19
Fuel Tank, TA-TB & TC	Page 20
Fuel Tank, TD-TF	Page 20
Fume Excluder, TA-TB & TC	Page 49
Fume Excluder, TD	Page 50
Fume Excluder, TF	Page 51
Fuses & Fuse Block	Page 35

G

Gasket Set, Engine	Page 09
Gasket Set, Gearbox, TB & TC	Page 15
Gasket Set, Gearbox, TD & TF	Page 17
Gear Knob, TB & TC	Page 14
Gear Knob, TD & TF	Page 17
Gear Lever, TB & TC	Page 14
Gear Lever, TD & TF	Page 17

Gearbox Components, TB & TC	Page 14
Gearbox Components, TD & TF	Page 16
Gearbox Cover, TA-TB & TC	Page 49
Gearbox Cover, TD	Page 50
Gearbox Cover, TF	Page 51
Glove Box	Page 38
Glove Box Top	Page 38
Grab Handles	Page 38
Grose-Jets, (Needle & Valve)	Accessories

H

HT Leads	Page 34 & Accessories
Handbrake Components, TA-TB & TC	Page 22
Handbrake Components, TD & TF	Page 24
Handbrake, TA-TB & TC	Page 22
Handbrake, TD & TF	Page 24
Hardware, (Nuts/Bolts etc.)	Page 62
Headlamps	Page 36
Headlamp Bulbs	Page 36
Headlamp Stone Guards	Accessories
Headlamps, Tripod	Accessories
Hood Fittings	Page 60
Hood Frame	Page 60
Hood Rails	Page 60
Hoods	Page 60
Horn	Page 35
Horn Switch	Page 38
Hub Bearings, Front, TA-TB & TC	Page 26
Hub Bearings, Front, TD & TF	Page 27
Hub Bearings, Rear, TA-TB & TC	Page 30
Hub Bearings, Rear, TD & TF	Page 31
Hub Caps, TD	Page 54
Hub Caps, TF	Page 56
Hub Seals, Front, TA-TB & TC	Page 26
Hub Seals, Front, TD & TF	Page 27
Hub Seals, Rear, TA-TB & TC	Page 30
Hub Seals, Rear, TD & TF	Page 31
Hub, Front, TA-TB & TC	Page 26
Hub, Front, TD & TF	Page 27
Hub, Rear, TA-TB & TC	Page 30
Hub, Rear, TD & TF	Page 31

I

Identification Tags, Engine	Page 07
Ignition Coils	Page 34 & Accessories
Ignition Leads	Page 34 & Accessories
Ignition/Headlamp Switch	Page 38
Instrument Panel Paint	Page IBC
Instruments	Page 38

J

Jack	Accessories
Jets, (Carbs)	Page 18

K

Key Fobs	Accessories
King Pins, TA-TB-TC	Page 26
King Pins, TD-TF	Page 27

L

L.T. Leads	Page 34
Lamps, Headlamps	Page 36
Lamps, Side, Tail etc.	Page 37
Lamps, Warning	Page 38
Leaf Spring, Front, TA-TB-TC	Page 26
Leaf Spring, Rear, TA-TB-TC	Page 28
Leaf Spring, Rear, TD-TF	Page 28
LHD To RHD Conversion Parts, TD-TF	Page 25
Lights, Panel & Accessory Switch	Page 38
Lubrication Chart, Penrite Oil	Page 13
Luggage Rack, TA-TB-TC	Page 52
Luggage Rack, TD	Page 54
Luggage Rack, TF	Page 56

M

Main Bearings	Page 08
Manifold, Air Cleaner	Page 19
Map Light	Page 38
Master Cylinder, Brake, TA-TB & TC	Page 22

Master Cylinder, Brake, TD & TF	Page 23
Medallion, Radiator, TA-TB & TC	Page 52
Medallion, Radiator, TD	Page 54
Medallion, Radiator, TF	Page 56
Mirrors, TA-TB & TC	Page 52
Mirrors, TD	Page 54
Mirrors, TF	Page 56
Moto-Lita Steering Wheel	Accessories

N

Needle & Seat, (See Also Grose-Jets)	Page 18
Needle, Carburettor	Page 18
Number Plate Lamp	Page 37
Nuts, (General Fasteners)	Page 62

O

Oils & Lubricants, (Penrite)	Page 13
Oil Cooler Kits	Page 10 & Accessories
Oil Filter, (Standard)	Page 06
Oil Filter, (Conversion)	Accessories
Oil Pressure Gauge	Page 38
Oil Pressure/Water Temp. Gauge	Page 38
Oil Pump	Page 06
Oil Temperature Gauge	Page 38

P

Paint, Engine	Page IBC
Paint, Hood Frame	Page IBC
Paint, Instrument Panel	Page IBC
Paints	Page IBC
Pedal Pad, (Brake & Clutch)	Page 12
Penrite Oil	Page 13
Pinion Gear, TA-TB & TC	Page 30
Pinion Gear, TD-TF	Page 31
Piping Sets, Wing, TA-TB & TC	Page 49
Piping Sets, Wing, TD	Page 50
Piping Sets, Wing, TF	Page 51
Pistons & Piston rings	Page 08
Propshaft, (All Models)	Pages 15 & 17
Pulley, Dynamo	Page 32

R

Rack & Pinion, TD & TF	Page 25
Radiator Cap, TA-TB & TC	Page 10
Radiator Cap, TD & TF	Page 10
Radiator Hoses	Page 11
Radiator Mountings, TA-TB & TC	Page 10
Radiator Mountings, TD & TF	Page 10
Radiator Shell/Grille, TA-TB & TC	Page 52
Radiator Shell/Grille, TD	Page 54
Radiator Shell/Grille, TF	Page 56
Rear Axle, TA-TB & TC	Page 30
Rear Axle, TD & TF	Page 31
Rear Differential, TA-TB & TC	Page 30
Rear Differential, TD & TF	Page 31
Rear Differential, TD & TF	Page 31
Reflectors	Page 37
Regulator	Page 35
Reverse Light Switch	Page 35
Ring Gear	Page 12
Rockers	Page 08
Rocker Adjusters	Page 08
Rocker Cover	Page 06 & Accessories
Rocker Pedestal	Page 08
Rocker Shaft	Page 08
Rotor Arm	Page 34
Rubber Components, TA-TB & TC	Page 49
Rubber Components, TD	Page 50
Rubber Components, TF	Page 51
Running Board Piping	Page 49

S

Scuttle, TA & TB	Page 40
Scuttle, TC	Page 42
Scuttle, TD	Page 44
Scuttle, TF	Page 46
Seat Assemblies	Page 58
Seat Components	Page 59
Seat Foams	Page 59
Seat Frames	Page 59
Seat Kits	Page 58

Seat Padding	Page 59
Seats	Page 58
Sender Unit, Fuel	Page 19
Shock Absorber, Front, TA-TB & TC	Page 26
Shock Absorber, Front, TD & TF	Page 27
Shock Absorber, Rear, TA-TB & TC	Page 28
Shock Absorber, Rear, TD & TF	Page 28
Shock Bush Installation Kit	Pages 27 & 28
Side Lamp	Page 37
Side Screen Covers	Page 61
Side Screen Frames	Page 61
Side Screen Stowage Bags	Page 61
Slow Running Cable	Page 19
Speedometer	Page 38
Speedometer Cables	Page 38
Spokes, (Wire wheels)	Page 21
Squab/Cushion Sets	Page 59
Starter	Page 32
Starter Cables	Pages 19 & 33
Starter Components	Page 32
Starter Switch	Pages 33 & 35
Starter Handle	Page 32
Steering Arms, TD & TF	Page 27
Steering Arms, TA-TB & TC	Page 26
Steering Box Components, TA-TB & TC	Page 24
Steering Box, TA-TB & TC	Page 24
Steering Bushes, TA-TB & TC	Page 26
Steering Bushes, TD & TF	Page 26
Steering Column, TD & TF	Page 27
Steering Kit, Tompkins, TA-TB & TC	Page 24
Steering Knuckle, TA-TB & TC	Page 25
Steering Knuckle, TD & TF	Page 27
Steering Rack & Pinion, TD & TF	Page 25
Steering Wheel, Moto-Lita	Accessories
Steering Wheel, TA-TB & TC	Page 24
Steering Wheel, TD & TF	Page 25
Stop Light Switch, TA-TB & TC	Page 22
Stop Light Switch, TD & TF	Page 23
Sun Visors	Accessories
Suspension, Front, TA-TB & TC	Page 26
Suspension, Front, TD & TF	Page 27
Suspension, Rear, TA-TB & TC	Page 28
Suspension, Rear, TD & TF	Page 28
Switch, Brake Light, TA-TB & TC	Page 22
Switch, Brake Light, TD & TF	Page 23
Switch, Dip-Floor Mounted	Page 35
Switch, Fog Light	Page 38
Switch, Horn/Dip	Page 38
Switch, Ignition/Headlamp	Page 38
Switch, Light Panel, Accessory	Page 38
Switch, Reverse Light	Page 35
Switch, Starter	Pages 33 & 35
Switch, Turn Signal	Page 35
Switches	Pages 35 & 38
T	
Tachometer Cable	Pages 32 & 38
Tachometers	Page 38
Tail Lamp	Page 37
Tap & Die Set	Page 62
Tappet Cover	Page 07 & Accessories
Thermostat	Page 11
Thermostat Housing	Page 11
Thread Restorer	Page 27
Thread Fittings On MG 'T' Types	Page 62
Threshold Plates, TA-TB & TC	Page 52
Threshold Plates, TD	Page 54
Threshold Plates, TF	Page 56
Timber Components, TA & TB	Page 41
Timber Components, TC	Page 43
Timber Components, TD	Page 45
Timber Components, TF	Page 47
Tompkins Steering Kit, TA-TB & TC	Page 24
Tonneau Covers	Page 60
Tonneau Fittings	Page 60
Tool Roll	Page 21
Tools, Roadside	Page 21
Tools, Wheel	Accessories
Trim Colour Charts	Page IBC
Trim Kits	Page 58
Trim Material	Page 58
Turn Signal Lamp, Rear	Page 37
Turn Signal Switch	Page 35
Tyre Lever Set	Page 21
Tyres, TA-TB & TC	Page 49
Tyres, TD	Page 50
Tyres, TF	Page 51
U	
Under Dash Shield Kit	Page 39
Universal Joints, Propshaft	Pages 30 & 31
V	
Valve Guides	Page 08
Valve Springs	Page 08
Valves, Inlet & Exhaust	Page 08
Voltage Regulator	Page 35
W	
Warning Lamps	Page 38
Water Pump	Page 11
Water Pump Components	Page 11
Water Temperature Gauge	Page 38
Wheel Cylinders, TA-TB & TC	Page 22
Wheel Cylinders, TD & TF	Page 23
Wheel Paint	Page IBC
Wheel Spinner, TA-TB & TC	Page 21 & Acc.
Wheel Spinner, TD & TF	Page 21 & Acc.
Wheel Tools	Accessories
Wheel, Wire	Page 21
Wheel, Wire, Conversion Kit, TD & TF	Page 21
Wheels	Page 21
Wind Wing Set	Page 55 & Accessories
Windscreen Fittings, TA-TB & TC	Page 53
Windscreen Fittings, TD	Page 55
Windscreen Fittings, TF	Page 57
Wing Covers	Page 40
Wing Piping	Pages 49, 50 & 51
Wings, TA & TB	Page 40
Wings, TC	Page 42
Wings, TD	Page 44
Wings, TF	Page 46
Wiper Arm	Page 35
Wiper Blades	Page 35
Wiper Components	Page 35
Wiper Motor	Page 35
Wiper Wheelbox	Page 35
Wire Wheel Conversion Kit, TD & TF	Page 21
Wire Wheels, TA-TB & TC	Page 21
Wire Wheels, TD & TF	Page 21
Wiring Looms	Page 33

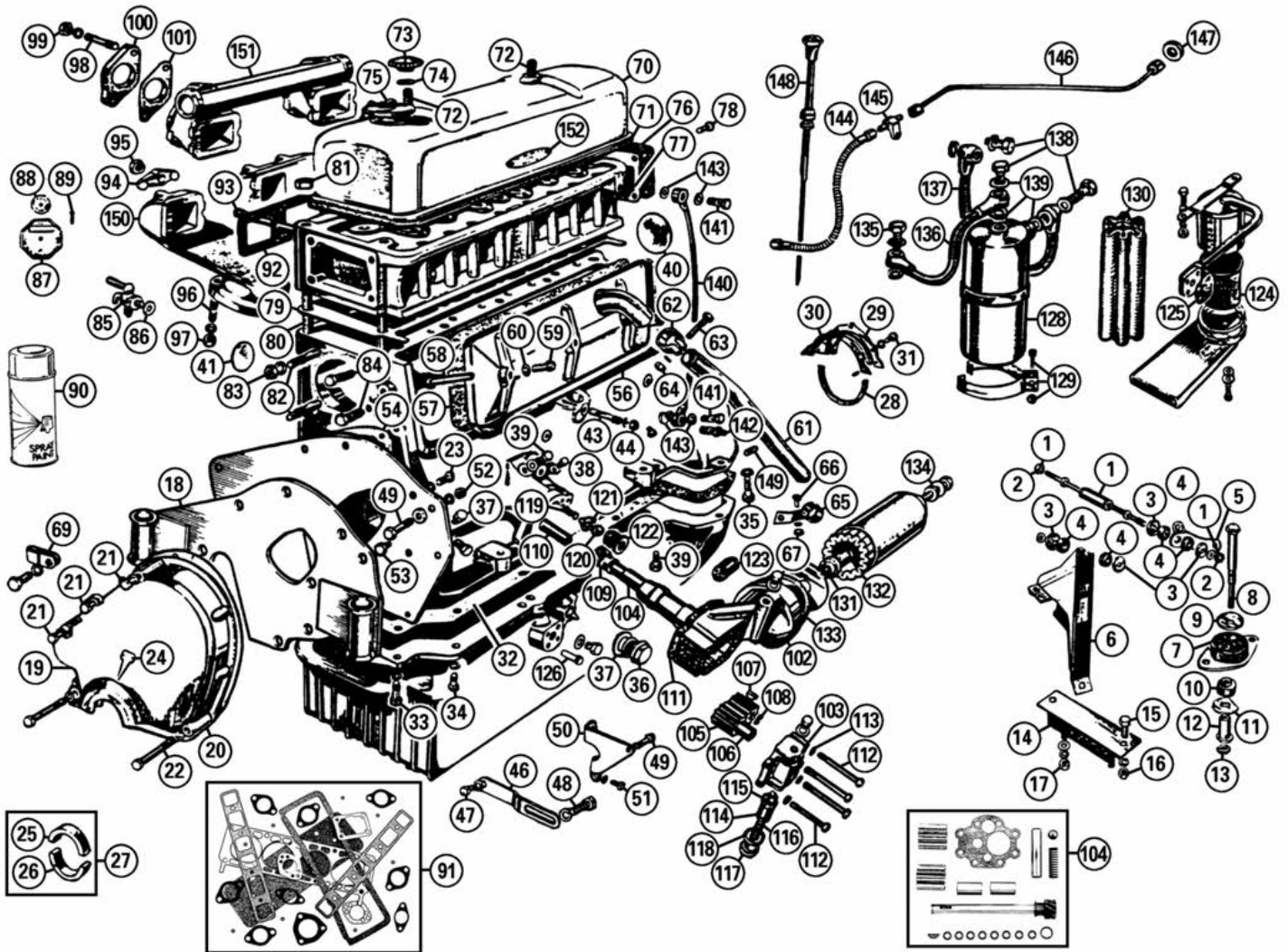

iii. Part Number Price £ea. Description Req. Details

External Engine

A Brief History of the 'T' Type Engine

The new MG TA should have had a Wolseley overhead camshaft engine, but it was cheated of this power unit at the last moment by Leonard Lord. Rationalisation plans forced them to use the "new" version of the old side valve unit designed by Hotchkiss & Cie, destined for the Wolseley 10/40 saloon. The engine (coded MPJG) was modified further just in time for the release of the TA, using twin SU carbs, modified camshaft and exhaust manifold.

1939 saw the introduction of the MG TB with a 1250cc XPAG engine (from the new Morris 10 XPJM unit). This engine was used (with further modifications in 1951 for TDII models) right up to the end of production of the TF model.

The 1500cc XPEG power unit (introduced in 1954, and running concurrently with the older XPAG engine) was the result of a major redevelopment of the XPASG unit and were mostly fitted to TF's that were destined for the American market.

Note: Although our supply of TA components is somewhat limited, if there is a specific component that you require that we have not illustrated/listed, please don't give up hope. For there are occasions when we hear of items (sometimes original) that suddenly become available, please contact your nearest Moss branch for latest information.

JR Supercharger Kit

NI 150-008 NCA SUPERCHARGER KIT 1 all models

Engine Mountings & Stabilisers

1	411-050	£47.00	STABILISER LINK	1
2	311-155	£1.39	LOCK NUT, adjuster	2
3	324-988	£3.52	WASHER SET, control link, (4 washers)	1
4	281-158	£7.20	BUSH SET, control link, (4 bushes)	1
5	411-040	£15.10	BRACKET, control link	1
6	411-060	£77.30	BRACKET, engine control, on chassis	1
7	410-010	£23.40	ENGINE MOUNTING, front	2
8	320-920	£12.05	BOLT, engine mounting	2
9	410-030	£7.60	WASHER, engine mounting	2

iii. Part Number Price £ea. Description Req. Details

10	410-020	£10.50	REBOUND RUBBER	2	TA-TB & TC
11	324-490	£0.76	WASHER, rebound rubber	2	
12	311-530	£11.04	SLEEVE NUT, engine mounting	2	
13	AJD8105Z	£0.18	LOCK NUT, sleeve nut	2	
14	411-010	£36.70	ENGINE MOUNTING, front	1	
15	320-560	£1.90	BOLT, front engine mounting	2	TD & TF
16	AJD8106Z	£0.29	NUT, mounting bolt	2	
17	AJD8106Z	£0.29	NUT, front engine mounting	2	
18	433-635	£142.50	ENGINE PLATE	1	TB & TC
18	433-645	£74.50	ENGINE PLATE	1	TD & TF
19	NCA		COVER, timing chain	1	TB-TC-TD & TF
20	291-600	£2.05	GASKET, timing chain cover	1	
21	320-300	£5.39	MEDIUM BOLT, timing cover	3	
22	320-310	£5.34	LONG BOLT, timing cover	2	
23	320-260	£0.86	SHORT BOLT, timing cover	2	
24	433-590	NCA	TDC INDICATOR	1	TB-TC-TD & TF
25	291-700	£4.27	UPPER SEAL, front crankshaft	1	
26	291-100	£5.60	LOWER SEAL, front crankshaft	1	
26	120-750	£10.80	OIL SEAL*, (uprated), front crankshaft	1	
27	433-421	£180.00	OIL SEAL CONVERSION KIT, rear	1	
27	433-422	£42.20	OIL SEAL, (replacement)	1	
27	433-425	£56.80	'SPEEDY SLEEVE'	1	
28	291-200	£7.10	SEAL, rear crankshaft	1	
29	433-410	£24.00	OIL THROWER, rear upper main	1	
30	291-900	£1.49	GASKET, rear oil thrower	1	
31	320-130	£0.82	BOLT, rear oil thrower	3	
32	AAA5659X	£19.00	GASKET SET, sump, (2 piece)	1	
33	320-265	£2.90	BOLT, front sump	2	
34	320-270	£1.94	BOLT, centre sump	10	
35	320-290	£0.98	BOLT, rear sump	2	TB-TC-TD & TF
36	328-120	£13.05	PLUG, oil drain	1	
37	6K431B	£0.60	WASHER, oil drain plug	1	

*Note: Modern (easy fit) lip-type to replace items 25 & 26. These lip-type seals replace the original leak prone impregnated rope seals. The modern seal fits into the original recess and glued in place with silicone gasket maker (part no. GGL1009).

*Note: Our modified oil seal assembly replaces items 27, 28, 29 & 30.

*Note: Our 'Speedy Sleeve' compensates for wear and/or corrosion on the flywheel flange.

Ill.	Part Number	Price £ea.	Description	Req.	Details
38	328-100	£1.55	PLUG, oil feed hole	5	
39	328-070	£5.75	PLUG, oil by-pass hole	1	
	328-020	£20.85	PLUG, front oil gallery	1	
	328-030	£1.20	PLUG, rear oil gallery	1	
40	AAA5561	£1.00	CORE PLUG, large	2	
41	319-050	£8.34	CORE PLUG, small	7	TA
	CA1056	£1.03	CORE PLUG, small	6	TB-TC-TD & TF
43	433-540	£39.00	COTTER CLAMP BOLT, distributor	1	TD From (c) 20942, TF
44	AJD8104	£0.34	NUT, distributor clamp bolt	1	
46	433-650	£26.40	ADJUSTING LINK, dynamo	1	
47	320-260	£0.86	BOLT, adjusting link	1	
48	322-510	£0.50	BOLT, dynamo	1	
49	320-290	£0.98	BOLT, dynamo	2	TB-TC-TD & TF
50	433-640	£36.70	BRACKET, rear dynamo mounting	1	
51	320-260	£0.86	BOLT, rear dynamo bracket	2	
52	311-100	£1.24	NUT, dynamo bolt	2	
53	320-260	£0.86	BOLT, bearer plate to block	2	
54	291-800	£1.39	GASKET, bearer plate	1	
56	224-240	£84.50	COVER, tappet, cast aluminium	1	
57	290-610	£7.93	GASKET, tappet inspection cover	1	TA
	290-600	£5.05	GASKET, tappet inspection cover	1	TB-TC-TD & TF
58	328-710	£3.66	STUD, tappet cover	3	
59	433-340	£4.52	NUT, tappet cover	3	TB-TC-TD & TF
60	WF509	£0.29	WASHER, tappet cover	3	
61	451-150	£20.00	BREATHER PIPE, tappet cover	1	TB & TC
	451-160	£29.50	BREATHER PIPE, tappet cover	1	TD & TF
62	433-800	£15.70	UPPER CLAMP, breather pipe	1	
63	320-200	£1.14	BOLT, upper clamp	1	
64	AJD8104	£0.34	NUT, upper clamp	1	TB-TC-TD & TF
65	433-620	£15.15	LOWER CLAMP, breather pipe	1	
66	AJD6155Z	£0.70	BOLT, lower clamp	1	
67	AJD8104	£0.34	NUT, lower clamp	1	
69	372-610	£3.52	CLIP, carburettor overflow pipe	1	
70	224-225	£185.00	ROCKER COVER*, alloy, non finned	1	TB & TC
	224-226	£180.00	ROCKER COVER*, alloy, finned	1	TD
	224-245	£209.00	ROCKER COVER*, alloy, finned	1	TF
			(*Rocker cover features MG logo and includes filler cap).		
71	290-310	£12.28	GASKET, rocker cover	1	TA, rubberised cork
	290-300	£10.05	GASKET, rocker cover	1	TB-TC-TD & TF
			(Rubberised cork).		
72	328-770	£5.70	STUD, rocker cover	2	
73	433-560	£10.60	BAKELITE THUMB NUT	2	
74	324-610	£0.30	WASHER, rocker cover nut	2	
75	433-490	£30.80	FILLER CAP, oil, (original cover only)	1	TB-TC-TD & TF
76	433-310	£7.45	COVER PLATE, rear head	1	
77	290-800	£1.60	GASKET, rear cover plate	1	
78	323-180	£3.50	SCREW, rear cover plate	4	
79	290-010	£121.12	GASKET, cylinder head	1	TA
	290-000	£57.95	GASKET, cylinder head	1	1250cc To (e) 22734
			(Elongated water holes).		
	290-100	£84.50	GASKET, cylinder head	1	1250cc From (e) 22735
			(Round water holes).		
	290-200	£52.80	GASKET, cylinder head	1	1500cc engines
80	328-781	£5.60	STUD, cylinder head, (long)	4	TA
	328-782	£6.00	STUD, cylinder head, (short)	7	
	328-780	£5.18	STUD, cylinder head	10	
81	311-200	£1.60	NUT, cylinder head stud	10	
82	328-750	£6.80	STUD, water pump mounting	2	
83	311-100	£1.24	NUT, water pump stud	2	
84	320-290	£0.98	BOLT, water pump mounting	2	TB-TC-TD & TF
85	434-240	£26.50	TAP, water drain, in block	1	
86	WF509	£0.29	WASHER, water drain tap	1	
87	408-770	£6.30	'ID' TAG, blank, engine	1	
88	408-850	£5.18	BRASS BUTTON, ID tag, (TC style)	1	
89	FAS2	£0.40	RIVET, engine ID tag	1	
90	CCEP1	£15.00	ENGINE PAINT, maroon, aerosol	a/r	400ml
91	G100Z	£120.16	GASKET HEAD SET	1	TC-TD
92	290-410	£13.15	GASKET, manifold	1	TA
	290-400	£5.90	GASKET, manifold	1	TB-TC-TD & TF
93	318-000	£4.93	STUD, manifold	8	TA
	328-760	£3.76	STUD, manifold	4	TB-TC-TD & TF
94	433-630	£7.25	CLAMP, manifold	4	
95	311-100	£1.24	NUT, manifold clamp	8	
96	328-828	£6.90	STUD SET, exhaust flange, (3 studs)	1	TA-TB & TC
	328-808	£8.24	STUD SET, exhaust flange, (3 studs)	1	TD & TF
97	311-768	£5.54	NUT SET, exhaust flange, (3 nuts)	1	
	320-510	£1.03	BOLT, carburettor to manifold	4	TA-TB-TC & TD
98	328-810	£5.75	STUD, carburettor to manifold	4	
99	311-210	£2.45	NUT, carburettor to manifold stud	4	TF
100	AHH5713	£5.00	SPACER, carburettor to manifold	2	
101	162624	£0.41	GASKET, carburettor to manifold	2	TA-TB-TC & TD, (1 1/4")
	AEH551	£0.70	GASKET, carburettor to manifold	4	TD MkII (1 1/2") & TF
102			NCA BODY, oil pump	1	TB & TC
			NCA BODY, oil pump	1	TD To (e) 14223

Ill.	Part Number	Price £ea.	Description	Req.	Details
			NCA BODY, oil pump	1	TD From (e) 14224, TF
			NCA CAP, oil pump	1	TB & TC
			NCA CAP, oil pump	1	TD To (e) 14223
			NCA CAP, oil pump	1	TD From (e) 14224, TF
103			NCA CAP, oil pump	1	
	435-050		NCA CAP, oil pump	1	
104	435-088	£240.00	REBUILD KIT, oil pump	1	
105	435-128	£50.70	GEAR SET, oil pump, (2 gears)	1	
106	330-318	£72.60	BUSH SET, driving gear & housing	1	TB-TC-TD & TF
107	327-050	£0.40	KEY, driving gear	1	
108	326-010	£1.50	CIRCLIP, driving gear	1	
109	435-090	£94.55	SHAFT & GEAR	1	
110	435-130	£31.65	SHAFT, driven gear	1	
111	292-300	£2.20	GASKET, oil pump to block	1	all models
112	320-160	£4.26	BOLT, short	4	TB-TC & TD To (e) 14223
				2	TD From (e) 14224, TF
				2	TB, TC, TD To (e) 14223
				4	TD From (e) 14224, TF
	320-165	£3.60	BOLT, medium	2	TB-TC-TD & TF
				2	TB-TC-TD & TF
	320-170	£4.21	BOLT, long	1	all models
113	324-978	£1.64	WASHER SET, copper, (8 washers)	1	
114	435-170	£71.60	GUIDE, relief valve ball	1	TB-TC-TD & TF
115	329-530	£1.55	BALL, relief valve	1	
116	329-080	£5.90	SPRING, relief valve	1	TB-TC-TD & TF
117	435-180	£7.45	CAP, relief valve	1	
118	324-790	£5.05	WASHER, relief valve cap	1	
119	329-090	£5.54	SPRING, by-pass	1	
120	329-530	£1.55	BALL, by-pass	1	with separate filter
121	435-200	£28.30	BALL GUIDE	1	TB-TC & TD To (e) 14223
122	435-190	£22.00	BALL SET	1	
123	435-060		NCA VALVE, by-pass	1	fitted in late pump
124	291-500	£1.20	GASKET, oil screen	1	TD From (e) 15372, TF
	291-300	£1.33	GASKET, oil pick-up	1	TB-TC & TD To (e) 15371
125	291-400	£1.55	GASKET, oil pick-up	1	TD From (e) 15372, TF
126	320-150	£5.60	BOLT, oil pick-up to sump	a/r	TB-TC-TD & TF
128	435-360		NCA OIL FILTER ASSEMBLY, throw-away	1	
	435-385	£126.23	OIL FILTER ASSEMBLY, steel unit	1	TB-TC & TD To (e) 14223
			(With renewable element).		
	435-395	£8.00	ELEMENT, (for 435-385 assembly)	1	
129	435-310	£73.60	FILTER STRAP ASSEMBLY	1	TB & TC
	435-430	£72.60	FILTER STRAP ASSEMBLY	1	TD To (e) 14223
130	435-370	£27.80	ELEMENT, oil filter	1	TA
131	435-140	£56.10	ADAPTOR, filter bolt to pump	1	
132	8G683	£7.20	ELEMENT, oil filter, felt	1	TD From (e) 14224 & TF
133	8G619	£1.00	SEALING RING, oil filter	1	
134	7H1948	£0.50	SEAL, bolt	1	
135	321-018		NCA BOLT SET, oil pump flange, 2 bolts	1	TB & TC
136	435-440	£63.10	OIL PIPE, pump to filter	1	
137	435-450	£68.50	OIL PIPE, pump to filter	1	TD To (e) 14223
138	435-460	£73.60	OIL PIPE, filter to block	1	TB-TC & TD
139	324-958	£18.60	BANJO BOLT, oil pipe, (TB-TC uses 3)	1	To (e) 14223
	324-968	£12.05	WASHER SET, copper, (6 washers)	1	TB & TC
		£16.60	WASHER SET, copper, (8 washers)	1	TD To (e) 14223
140	435-510	£73.60	OIL PIPE, head to block	1	TB-TC & TD To (e) 9407
	435-520	£79.80	OIL PIPE, head to block	1	TD From (e) 9408, TF
141	435-465	£9.26	BANJO BOLT, round	1	TB-TC & TD To (e) 9407
	435-490	£10.94	BANJO BOLT, hexagon	2	TD From (e) 9408, TF
142	435-500	£12.28	BANJO BOLT, (with flex pipe adaptor)	1	TB-TC & TD To (e) 9407
143	324-760	£1.10	WASHER, banjo bolt	4	
144	AAA627	£13.00	OIL PIPE, flexible, (to bulkhead fitting)	1	TB-TC-TD & TF
145	AAA628	£10.45	FITTING, oil pipe	1	
146	435-528		NCA OIL PIPE, block to gauge	1	TA
	AHH5323	£15.00	OIL PIPE, fitting to gauge	1	TB-TC-TD & TF
147	2K4936	£0.20	WASHER, leather	1	
148	433-830	£44.20	DIPSTICK	1	TB & TC
	433-820	£26.50	DIPSTICK	1	TD & TF
149	325-318	£1.80	DOWEL SET, bell housing	1	
150	454-305	£354.00	EXHAUST MANIFOLD	1	
151	373-360	£158.00	INLET MANIFOLD, 1 1/4"***	1	TB-TC & TD
152	408-745	£20.10	PLATE, valve clearance, 0.012"	1	
	408-735	£20.10	PLATE, valve clearance, 0.019"	1	

***Note: Can be used on TD MkII & TF if the inlet ports are bored to 1 1/2".

Cylinder Head Depth

Original 1250 or 1500 cylinder heads had a thickness of 3.022", but over the years, many have been excessively machined, causing problems with detonation and/or overheating. Two head gaskets can be fitted, which will increase the effective cylinder head thickness by approximately 0.045".

Rebuilding T Type Oil Pumps

Most 'T' Type oil pumps can be rebuilt to like-new condition, but care must be exercised that proper gear end float clearances are obtained. Specifications are listed in the workshop manuals and the machine work can be entrusted to your local (& competent) machine shop.

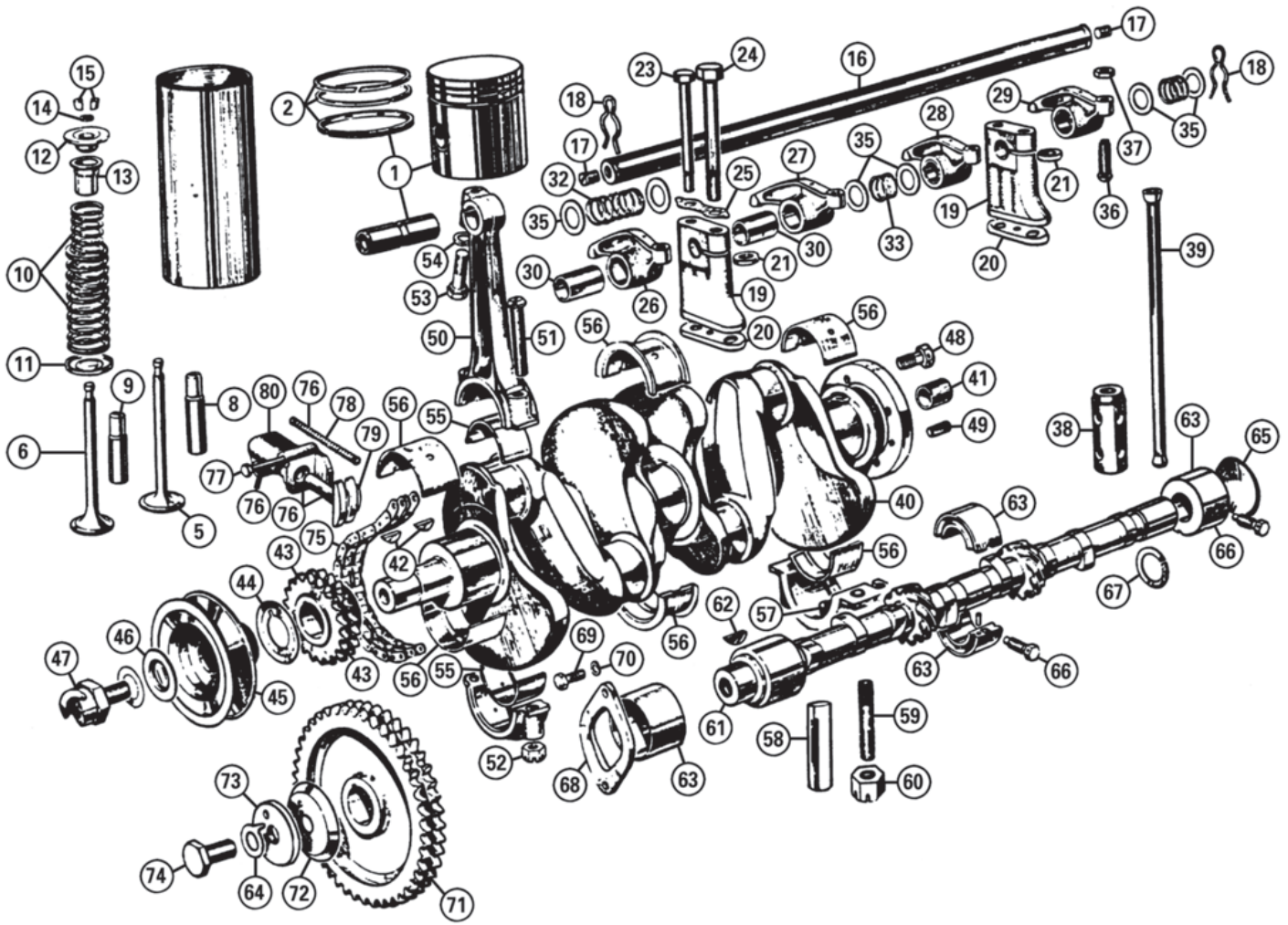

Part Number	Price £ea.	Description	Req.	Details
Internal Engine				
Pistons, Rings & Valves				
We are pleased to offer a complete range of Aerolite brand pistons. These high quality pistons are manufactured to the original solid skirt 3-ring design, but incorporate the very latest in high strength, high silicon content aluminium alloy. All pistons are produced in permanent steel moulds for maximum strength yet light weight.				
1	420-018 £294.00	PISTON SET, standard	1	TB-TC-TD & TF, 1250cc engines
	420-038 £294.00	PISTON SET, 0.020"	1	
	420-048 £294.00	PISTON SET, 0.030"	1	
	420-058 £294.00	PISTON SET, 0.040"	1	
	420-068 £294.00	PISTON SET, 0.060"	1	
	420-078 £294.00	PISTON SET, 0.080"	1	
	420-088 £294.00	PISTON SET, 0.100"	1	
	420-098 £294.00	PISTON SET, 0.120"	1	
	420-218 £380.00	PISTON SET, standard	1	
	420-238 £380.00	PISTON SET, 0.020"	1	
	420-258 £380.00	PISTON SET, 0.040"	1	TF, 1500cc engines
	420-268 £380.00	PISTON SET, 0.060"	1	
2	421-010 £71.00	RING SET, standard	1	(3 ring Mowag & Aerolite pistons), 1250cc engines
	421-020 £71.00	RING SET, 0.020"	1	
	421-030 £71.00	RING SET, 0.030"	1	
	421-040 £71.00	RING SET, 0.040"	1	
	421-050 £71.00	RING SET, 0.060"	1	
	421-060 £99.20	RING SET, standard	1	
	421-070 £99.20	RING SET, 0.020"	1	
	421-080 £99.20	RING SET, 0.030"	1	
	421-090 £99.20	RING SET, 0.040"	1	
	421-100 £99.20	RING SET, 0.060"	1	
	421-110 £99.20	RING SET, 0.080"	1	
	421-120 £88.50	RING SET, 0.100**	1	
	421-130 £88.50	RING SET, 0.120**	1	
	421-190 £98.50	RING SET, standard	1	
	421-200 NCA	RING SET, 0.020"	1	

Part Number	Price £ea.	Description	Req.	Details
421-210	£95.95	RING SET, 0.030"	1	4-ring pistons), 1500cc
421-220	£95.95	RING SET, 0.040"	1	
421-230	NCA	RING SET, 0.060"	1	
*Note: These numbers are found stamped in the crowns of certain after-market pistons, and fit those pistons. We do not stock rings for other after-market pistons.				
3	426-010 £38.30	CYLINDER LINER, (sleeve)	4	1250cc engines
	426-030 £42.00	CYLINDER LINER, (sleeve)	4	1500cc engines
5	PWT892A £29.30	VALVE, inlet	4	TA
	423-010 £9.20	VALVE, inlet, 1 5/16" diameter	4	TB-TC & TD
	423-030 £10.44	VALVE, inlet, 1 7/16" diameter	4	TD MkII & TF
6	PWT893A £30.40	VALVE, exhaust	4	TA
	423-020 £11.70	VALVE, exhaust, 1 3/16" diameter	4	TB-TC & TD
	423-040 £15.15	VALVE, exhaust, 1 3/8" diameter	4	TD MkII & TF
	423-025 £22.95	EXHAUST VALVE, stellite faced	4	TB-TC & TD
	423-045 £24.00	EXHAUST VALVE, stellite faced	4	TD MkII & TF
8	PWT891TA £21.80	GUIDE, inlet	4	TA
	P100 £7.12	GUIDE, inlet	4	TB-TC-TD & TF
	423-215 £7.40	SILICON BRONZE VALVE GUIDE, inlet**	4	TA
9	PWT891TA £21.80	GUIDE, exhaust	4	
	P101 £5.45	GUIDE, exhaust	4	TB-TC-TD & TF
	423-225 £7.90	SILICON BRONZE VALVE GUIDE, exhaust**	4	TA
**Note: The low friction and high strength characteristics of silicon bronze means much less guide and valve stem wear than standard guides.				
10	PWT895 NCA	VALVE SPRING SET	1	TA
	423-410 £42.80	VALVE SPRING SET	1	TB-TC-TD & TF
11	433-030 £2.68	SPRING WASHER, bottom	8	
12	433-010 £13.15	SPRING WASHER, top	8	
13	1H725 £7.20	OIL DEFLECTOR, valve	8	
14	297-108 £2.10	OIL SEAL SET, valve stem, 8 seals	1	
	ADU4905 £0.60	OIL SEAL, improved, alternative***	8	
15	433-040 £2.54	VALVE COTTER, each	16	
***Note: If using improved oil seals ADU4905 then the oil deflector 1H725 is no longer needed.				

Unleaded Petrol and Your Valves

Today's unleaded fuel does not protect original style valves & valve seats against valve seat recession. We strongly recommend our Stellite-faced exhaust valves and silicone bronze valve guides. A full & permanent conversion to lead-free operation would also include fitting hardened exhaust valve seats. However, since valve seat inserts could conceivably loosen and fall out, causing considerable damage, we only recommend that these be fitted when inserts are also required to repair existing serious valve seat wear.

ill.	Part Number	Price £ea.	Description	Req.	Details
16	451-170	£28.15	SHAFT, rocker arm, 14" long	1	TB-TC & TD To (e) 9007
	451-180	£27.80	SHAFT, rocker arm, 14 7/8" long	1	TD From (e) 9008, TF
17	328-010	£17.75	PLUG, rocker shaft end	2	
18	506542	£0.50	CLIP, rocker shaft	2	
19	433-060	£17.50	ROCKER PEDESTAL	4	
20	433-128	£26.50	SHIM SET, (4 shims), use with milled head	1	TB-TC-TD & TF
21	433-080	£7.18	WASHER, spacer (For no. 1 & 4 pedestals, 'D' shaped)	2	
	433-070	£2.10	WASHER, spacer (For no. 2 & 3 pedestals, round)	2	
23	320-330	£4.43	BOLT, rocker bracket (8mm, 3 5/16" long).	8	TA
				4	TB-TC-TD & TF
24	320-530	£2.60	BOLT, rocker bracket (10mm, 3 1/2" long).	4	TB-TC-TD & TF
25	433-108	£4.27	LOCKPLATE SET, (4 lock plates)	1	TB-TC-TD & TF
26	433-150	£22.50	ROCKER, number 1 and 5 valve	2	TB-TC & TD To (e) 9007
	433-160	£22.50	ROCKER, number 1 and 5 valve	2	TD From (e) 9008, TF
27	433-170	£22.50	ROCKER, number 2 and 6 valve	2	TB-TC-TD & TF
28	433-180	£22.50	ROCKER, number 3 and 7 valve	2	
29	433-130	£22.50	ROCKER, number 4 and 8 valve	2	TB-TC & TD To (e) 9007
	433-140	£22.50	ROCKER, number 4 and 8 valve	2	TD From (e) 9008, TF
30	330-080	£5.50	BUSH, rocker, short	4	TB-TC & TD To (e) 9007
	330-090	£4.21	BUSH, rocker, long	4	used on 14" shaft
	330-090	£4.21	BUSH, rocker, long	8	TD from (e) 9008, TF
32	329-360	£11.86	SPACER SPRING, centre, long	1	TB-TC & TD To (e) 9007
	329-160	£9.76	SPACER SPRING, centre	1	TD From (e) 9008, TF
33	329-160	£9.76	SPACER SPRING, intermediate	2	TB-TC & TD To (e) 9007
	329-150	£13.90	SPACER SPRING (For front, intermediate & rear).	4	TD From (e) 9008, TF
34	329-150	£13.90	SPACER SPRING, front & rear	2	TB-TC & TD To (e) 9007
35	324-420	£4.07	WASHER, spacer spring	2	TB-TC & TD To (e) 9007
				10	TD From (e) 9008, TF
36	433-200	£6.80	ADJUSTING SCREW, rocker	8	TA-TB-TC & TD To (e) 17297
	433-210	£7.00	ADJUSTING SCREW, rocker	8	TD From (e) 17298, TF
37	311-110	£1.55	NUT, rocker adjusting screw	8	all models
38	AEG127	£7.10	CAM FOLLOWER, single	8	TB-TC-TD & TF
	AEG127020	£10.30	CAM FOLLOWER, single, 0.020"	8	
	433-365	£312.60	CAM FOLLOWER SET (For Crane Cams only. Part No: 451-260X, item 61).	1	
39	433-330	£9.37	PUSH ROD	8	
39a	433-335	£90.55	PUSH ROD SET, short	1	use with crane cam

Crankshaft

40	AAA3105	NCA	CRANKSHAFT, forged (forged in '4340 Chrome-Moly' steel)	1	
	AAA3105X	£1,670.00	CRANKSHAFT, billet (machined from EN40B steel)	1	
41	330-040	£8.50	BUSH, spigot	1	
42	327-050	£0.40	KEY, crankshaft	2	
	433-448	£98.60	SPROCKET SET, (inc. items 43, 71 & 75)	1	TB-TC-TD & TF
43	AAA5664	£36.70	SPROCKET, crankshaft	1	
44	433-480	£5.40	OIL THROWER, crankshaft	1	
45	433-470	£43.20	PULLEY, crankshaft	1	
46	433-460	£6.35	WASHER, crankshaft pulley	1	
47	433-450	£35.60	BOLT, crankshaft	1	
48	320-524	£10.44	BOLT, flywheel to crank	4	
49	325-328	£13.55	DOWEL SET, crankshaft, (2 pins)	1	
NI	P162	£42.80	RING GEAR*	1	TB & TC
	P163	£42.80	RING GEAR, 10 3/8" ID*	1	TD To (e) 9407
	P164	£43.10	RING GEAR, 10 3/4" ID*	1	TD From (e) 9408, TF

*Note: Please refer to page 12 (Clutch System) for illustration.

50	433-780	£377.60	CONNECTING ROD SET	4	1250cc engines
	433-790	NCA	CONNECTING ROD SET	4	1500cc engines
51	320-885	£17.25	BOLT, connecting rod	8	TA
	320-880	NCA	BOLT, connecting rod	8	TB-TC-TD & TF
	321-269	£94.55	BOLT & NUT SET, connecting rod (Contains 8 bolts and 8 nuts).	1	TB-TC-TD & TF
52	311-085	£4.05	NUT, connecting rod	8	TA
	311-080	£1.60	NUT, connecting rod	8	TB-TC-TD & TF
	321-269	£94.55	BOLT & NUT SET, connecting rod (Contains 8 bolts and 8 nuts).	1	TB-TC-TD & TF

ill.	Part Number	Price £ea.	Description	Req.	Details
53	320-899	£10.60	BOLT SET, gudgeon pin clamp (ARP socket bolt, engine set)	1	all models
	320-898	£31.50	BOLT SET, gudgeon pin clamp (hex headed bolt, engine set)	1	
54	GHF332	£0.19	WASHER, clamp bolt	4	

Con Rod & Main Bearings

55	424-000	£27.50	CON ROD BEARING SET, standard	1	
	424-100	£27.50	CON ROD BEARING SET, 0.010"	1	
	424-150	£27.50	CON ROD BEARING SET, 0.020"	1	
	424-200	£27.50	CON ROD BEARING SET, 0.030"	1	
	424-250	£27.50	CON ROD BEARING SET, 0.040"	1	
	424-300	£27.50	CON ROD BEARING SET, 0.050"	1	TB-TC-TD & TF
	424-350	£27.50	CON ROD BEARING SET, 0.060"	1	
56	424-650	£58.30	MAIN BEARING SET, standard	1	
	424-750	£58.30	MAIN BEARING SET, 0.010"	1	
	424-800	£58.30	MAIN BEARING SET, 0.020"	1	
	424-850	£58.30	MAIN BEARING SET, 0.030"	1	
	424-900	£58.30	MAIN BEARING SET, 0.040"	1	
	424-905	£58.30	MAIN BEARING SET, 0.050"	1	
	424-910	£58.30	MAIN BEARING SET, 0.060"	1	
57	325-050	£9.16	DOWEL PIN, main bearing insert	6	
58	433-600	NCA	PIPE, main bearing cap	1	TB-TC-TD & TF
59	328-830	£5.70	STUD, main bearing cap	6	
60	311-270	£2.24	NUT, main bearing cap stud	6	all models
61	451-260X	£427.00	CAMSHAFT, Crane Cam, standard grind 1 (Must be used with special cam followers Part no. 433-365, item 38).	1	
	451-260	£313.40	CAMSHAFT, standard grind	1	
	451-270	£338.20	CAMSHAFT, 3/4 grind	1	TB-TC-TD & TF
62	327-050	£0.40	KEY, camshaft sprocket	1	
63	424-968	£62.50	CAM BEARING SET	1	

New front cam bearings must be fitted each time the cylinder block is hot-tanked, as the caustic solution will destroy the thin wall bearing shell. New front cam bearings must be line-reamed after installation. This procedure must be entrusted to a competent automotive machine shop.

64	433-370	£6.10	TAB WASHER, cam sprocket	1	
65	328-240	£1.94	CORE PLUG, in block	1	
66	320-900	£13.55	BOLT, centre & rear cam bearing	2	
67	326-060	£0.50	CIRCLIP, rear camshaft	1	
68	433-400	£31.50	THRUST PLATE, camshaft	1	
69	320-130	£0.82	BOLT, cam thrust plate	2	
70	GHF331	£0.12	WASHER, thrust plate bolt	2	TB-TC-TD & TF
	433-448	£98.60	SPROCKET SET, (inc. items 43, 71, 75)	1	
71	AAA5666	£51.80	SPROCKET, camshaft	1	
72	433-390	£5.70	OIL THROWER, camshaft	1	
73	433-380	£31.65	WASHER, camshaft sprocket	1	
74	320-670	£3.58	BOLT, camshaft	1	
75	433-565	£15.65	TIMING CHAIN	1	TA
	433-580	£15.65	TIMING CHAIN	1	TB-TC-TD & TF
76	433-578	£38.80	TENSIONER ASSEMBLY, timing chain	1	
77	320-150	£5.60	BOLT, timing chain tensioner	2	
78	329-370	£5.39	SPRING, chain tensioner	1	TB-TC-TD & TF
79	433-570	£24.00	FOOT, timing chain tensioner	1	
80	433-575	£16.80	BODY, chain tensioner	1	

Gasket Sets

	297-708	£149.30	ENGINE GASKET SET, complete	1	1250cc To (e) 22734
	297-808	£149.30	ENGINE GASKET SET, complete	1	1250cc From (e) 22735
	297-908	£149.30	ENGINE GASKET SET, complete	1	1500cc engines
	297-218	£121.12	HEAD GASKET SET	1	TA
	G100	£127.80	HEAD GASKET SET	1	1250cc To (e) 22734
	G102	£127.80	HEAD GASKET SET	1	1250cc From (e) 22735
	297-408	£127.80	HEAD GASKET SET	1	1500cc engines
	297-228	£46.20	CONVERSION SET	1	TA
	297-238	£34.90	CONVERSION SET	1	
	AAA5659X	£19.00	SUMP GASKET SET	1	TB-TC-TD & TF
	GGC102	£5.90	GASKET SEALANT, (Hylomar)	a/r	

Oil Cooler Kits

The TB-TC and early TD kits are for early vertically-mounted oil filter applications. The connecting pipe (see External Engine on pages 06/07 - item No 136) is eliminated and oil pipes are connected directly to block and filter. Late style kits incorporate a cast aluminium 'sandwich' plate to fit between the oil pump and filter canister. Oil coolers are normally mounted below the splash apron. Oil coolers are not included with the installation kits and must be purchased separately.

	MM235-935	£47.20	OIL COOLER INSTALLATION KIT	1	TB-TC & TD To (e) 14223
	MM235-945	£106.40	OIL COOLER INSTALLATION KIT	1	TD From (e) 14224, TF
	AR09807	£66.00	OIL COOLER, 10 row	1	
	ARA221	£38.00	OIL COOLER, 13 row	1	

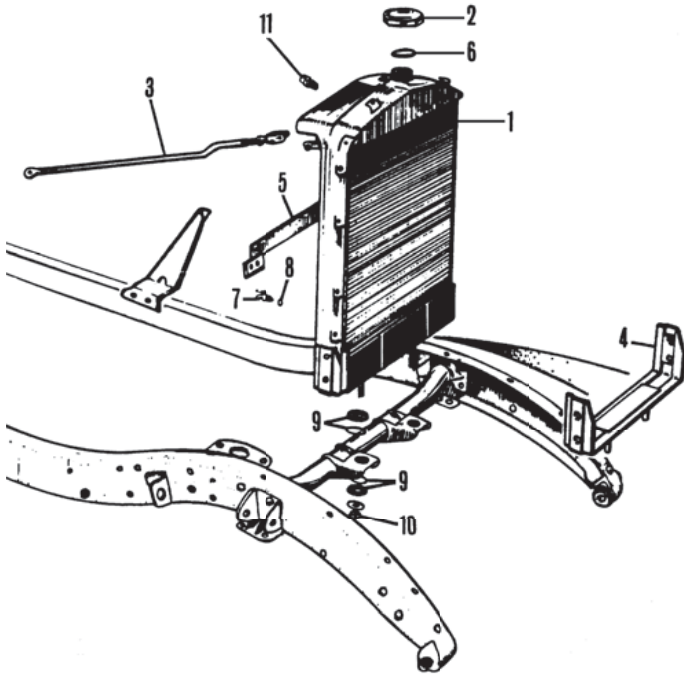

Radiator & Fittings - TA-TB & TC

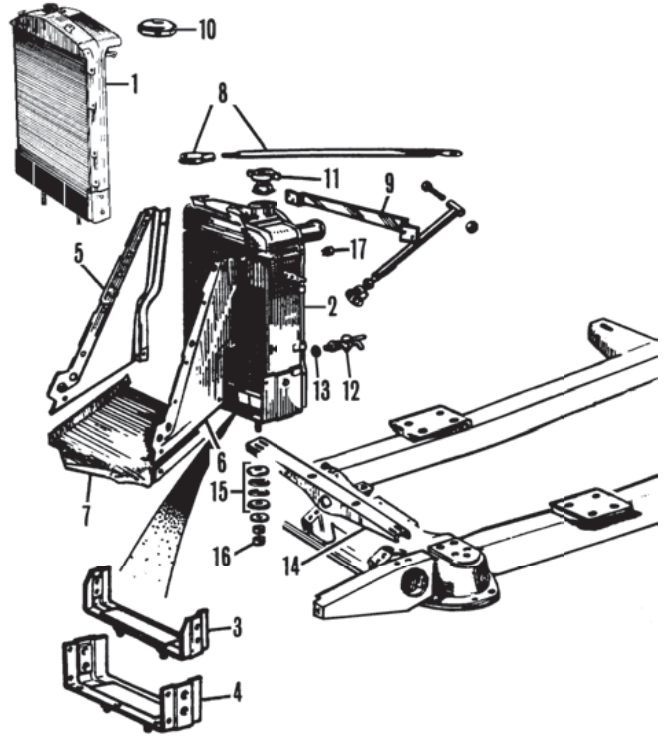

Radiator & Fittings - TD & TF

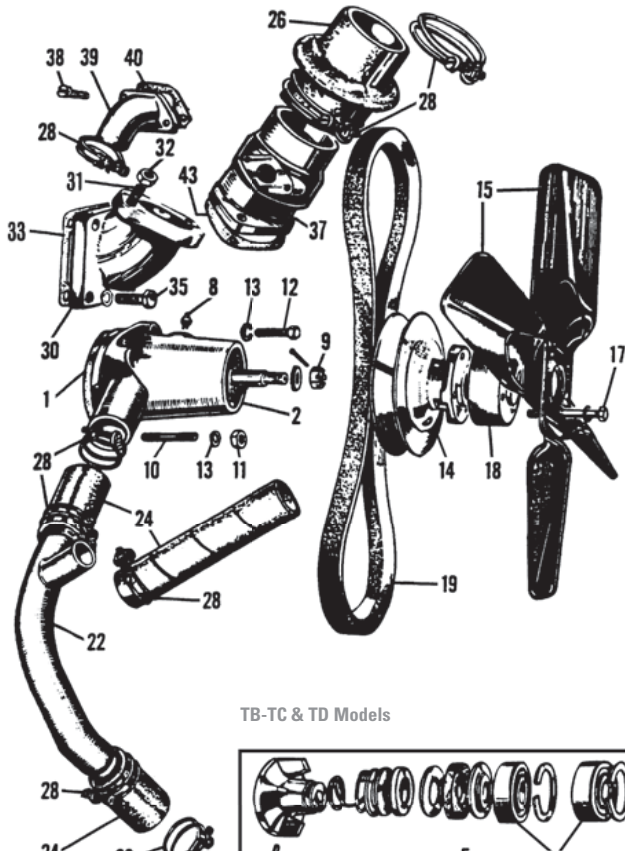

TB-TC & TD Models

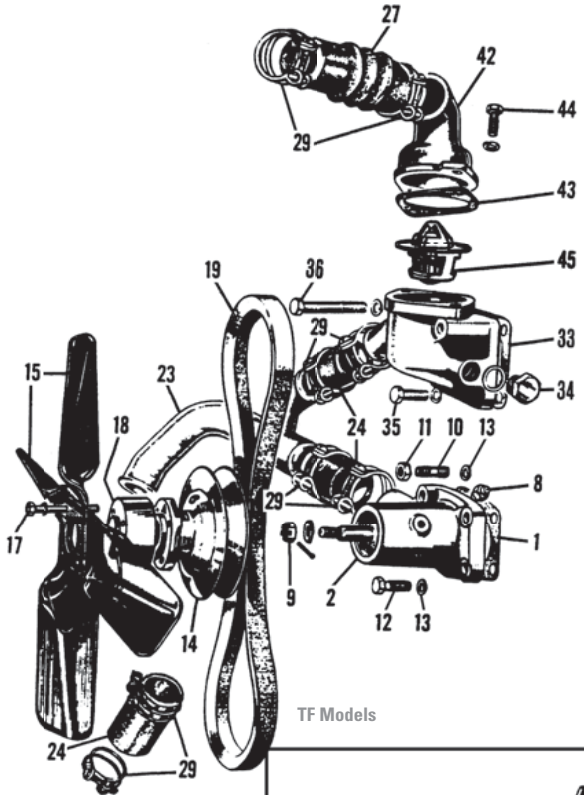
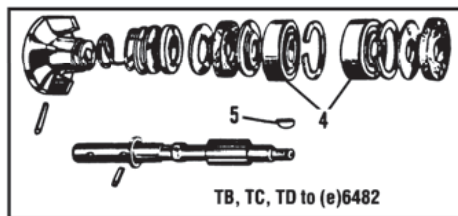

TF Models

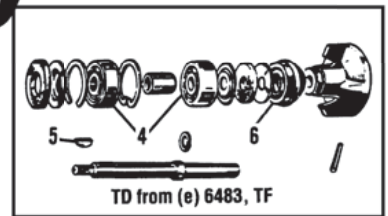

ill.	Part Number	Price £ea.	Description	Req.	Details
Cooling System					
Radiator & Fittings - TA-TB & TC					
1	453-980	£550.00	RADIATOR, new	1	TB & TC
2	202-010	£52.50	RADIATOR CAP, chrome	1	
Ni	386-260	£17.75	SPANNER, radiator cap	1	
3	451-760	£83.00	STAY BAR, radiator, cranked, RH	1	
	451-770	£83.00	STAY BAR, radiator, straight, LH	1	
4	454-135	£90.79	MOUNTING BRACKET	1	radiator to chassis
5	451-100	£60.10	TIE BRACKET, headlamp mounting	1	
6	280-020	£1.50	SEAL, radiator cap	1	
7	3H576	£18.00	DRAIN TAP, radiator	1	
8	2K4975	£0.29	FIBRE WASHER, drain tap	1	
9	281-648	£12.05	MOUNTING SET, radiator	1	8 pieces, inc. steel rings
10	AJD8106Z	£0.29	NUT, radiator mounting	4	
11	361-050	£12.05	ADAPTOR, temperature gauge pipe	a/r	male/female
	361-060	£16.80	ADAPTOR, to radiator	a/r	male/male

Radiator & Fittings - TD & TF					
1	453-980	£550.00	RADIATOR	1	TD
2	453-820	NCA	RADIATOR, (please enquire)	1	TF
3	454-135	£90.79	MOUNTING BRACKET	1	TD, radiator to chassis
4	449-590	£96.01	MOUNTING BRACKET	1	TF, radiator to chassis
5	454-130	£76.20	SIDE PLATE, radiator, RH	1	} TF
6	454-125	£76.20	SIDE PLATE, radiator, LH	1	
7	452-720	£57.00	BOTTOM PLATE, radiator	1	
8	451-700	£30.65	STAY BAR, radiator	2	
9	451-100	£60.10	TIE BRACKET, headlamp mounting	1	TD
10	202-010	£52.50	RADIATOR CAP, chrome	1	TD
11	GRC103	£4.30	RADIATOR CAP, 4lb, standard	1	} TF
	GRC101	£4.30	RADIATOR CAP, 7lb	1	
12	3H576	£18.00	DRAIN TAP, radiator	1	
13	2K4975	£0.29	FIBRE WASHER, drain tap	1	
14	451-200	NCA	BRACKET, radiator mounting	1	between chassis rails
15	281-648	£12.05	MOUNTING SET, radiator	1	8 pieces, inc. steel rings
16	AJD8106Z	£0.29	NUT, radiator mounting	4	
17	361-050	£12.05	ADAPTOR, temperature gauge pipe	a/r	male/female
	361-060	£16.80	ADAPTOR, to radiator	a/r	male/male

Water Pump, Fan & Thermostat					
1	PWT916A	NCA	GASKET, water pump	1	TA
	292-000	£1.06	GASKET, water pump	1	TB-TC-TD & TF
	PWT916	NCA	WATER PUMP	1	TA
2	AEF19	£54.20	WATER PUMP	1	TB-TC-TD & TF
4	AEF136	£13.35	BEARING, water pump	2	TB-TC-TD & TF
5	327-030	£0.97	KEY, water pump pulley	1	} TD From (e) 6483, TF
6	AEB156	NCA	SEAL, water pump	1	
8	328-520	£1.03	GREASE NIPPLE, water pump	1	
9	311-080	£1.60	NUT, spindle	1	TB-TC-TD & TF
10	328-750	£6.80	STUD, water pump mounting	2	} TB-TC-TD & TF
11	311-100	£1.24	NUT, water pump stud	2	
12	320-290	£0.98	BOLT, water pump mounting	2	
13	GHF332	£0.19	LOCK WASHER, stud & bolt	4	
14	434-060	£55.80	PULLEY, water pump	1	
15	434-108	£46.20	FAN BLADE SET, (2 blades)	1	} better cooling than 434-108
	12H4744	£54.50	FAN BLADE SET, plastic, (7 blades)	1	
17	320-110	£3.14	BOLT, fan blade	4	TB & TC
	320-120	£4.21	BOLT, fan blade	4	TD & TF
18	434-070	£44.20	SPACER, fan blade	1	TD & TF
19	434-110	£28.80	FAN BELT	1	TA
	434-125	£27.50	FAN BELT	1	TB-TC-TD & TF
22	434-215	NCA	BRANCH PIPE, water	1	TA
	434-210	£41.80	BRANCH PIPE, water	1	TB & TC
	434-220	£41.80	BRANCH PIPE, water	1	TD
23	434-230	£62.50	BRANCH PIPE, water	1	TF
24	434-438	£15.00	HOSE SET, lower, (3 hoses)	1	TB-TC-TD & TF
26	434-410	£17.00	RADIATOR HOSE, top	1	TA-TB-TC & TD
27	434-420	£8.70	RADIATOR HOSE, top	1	TF
28	326-388	£10.20	HOSE CLAMP SET, (8 clamps)	1	TA-TB-TC & TD
29	326-398	£10.50	HOSE CLAMP SET, (8 clamps)	1	TF
30	434-130	£83.20	WATER OUTLET	1	TB & TC
	434-140	£75.00	WATER OUTLET	1	TD
31	328-747	£3.66	STUD, water outlet	2	TB-TC & TD
32	311-100	£1.24	NUT, for stud	2	} TB-TC-TD & TF
33	290-700	£1.10	GASKET, water outlet	1	
34	AEK122	£8.00	PLUG, water outlet	1	
35	320-290	£0.98	BOLT, water outlet mounting	2/4	(TF uses 2)
36	NCA		BOLT, water outlet mounting	2	
37	434-168	£79.00	THERMOSTAT & HOUSING	1	
38	323-040	£0.92	SCREW, thermostat elbow	2	TA-TB-TC & TD
39	434-170	£71.60	ELBOW, thermostat housing	1	

ill.	Part Number	Price £ea.	Description	Req.	Details
40	292-200	£1.85	GASKET, thermostat elbow	1	} TF
42	434-150	£37.90	WATER OUTLET ELBOW	1	
43	115467	£0.34	GASKET, water outlet	1	all models
43	115467	£0.34	GASKET, thermostat housing, cork	1	} all models
	115467X	£1.03	GASKET, thermostat housing, Klingersil	1	
45	GTS102	£3.40	THERMOSTAT, replacement type (74°C, summer).	1	} TF
	GTS104	£3.60	THERMOSTAT, replacement type (88°C, winter).	1	
	GTS106	£4.20	THERMOSTAT, replacement type (88°C, winter).	1	

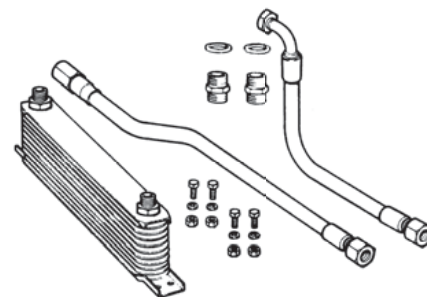

Oil Cooler Kits

Note: See also notes at the bottom of page 09 and also see the Accessories section for further details.

The TB-TC and early TD kits are for early vertically-mounted oil filter applications. The connecting pipe (435-460) is eliminated and oil pipes are connected directly to block and filter. Late style kits incorporate a cast aluminium 'sandwich' plate to fit between the oil pump and filter canister. Oil coolers are normally mounted below the splash apron. Oil coolers are not included with the installation kits and must be purchased separately.

MM235-935	£47.20	OIL COOLER INSTALLATION KIT	1	TB-TC & TD To (e)14223
MM235-945	£106.40	OIL COOLER INSTALLATION KIT	1	TD From (e)14224, TF
AR09807	£66.00	OIL COOLER, 10 row	1	
ARA221	£38.00	OIL COOLER, 13 row	1	

Spin-on Oil Filter Adaptor

Upgrade your TD & TF to use a modern efficient style spin-on cartridge type oil filter. As well as offering better filtration they make oil changes a cleaner and simpler operation. Includes adaptor, seals and fittings, filter not included. Suitable for TD's from (e) 14224 and TF models.

235-865	£101.26	SPIN-ON ADAPTOR KIT	1	
GFE173	£4.80	OIL FILTER	1	

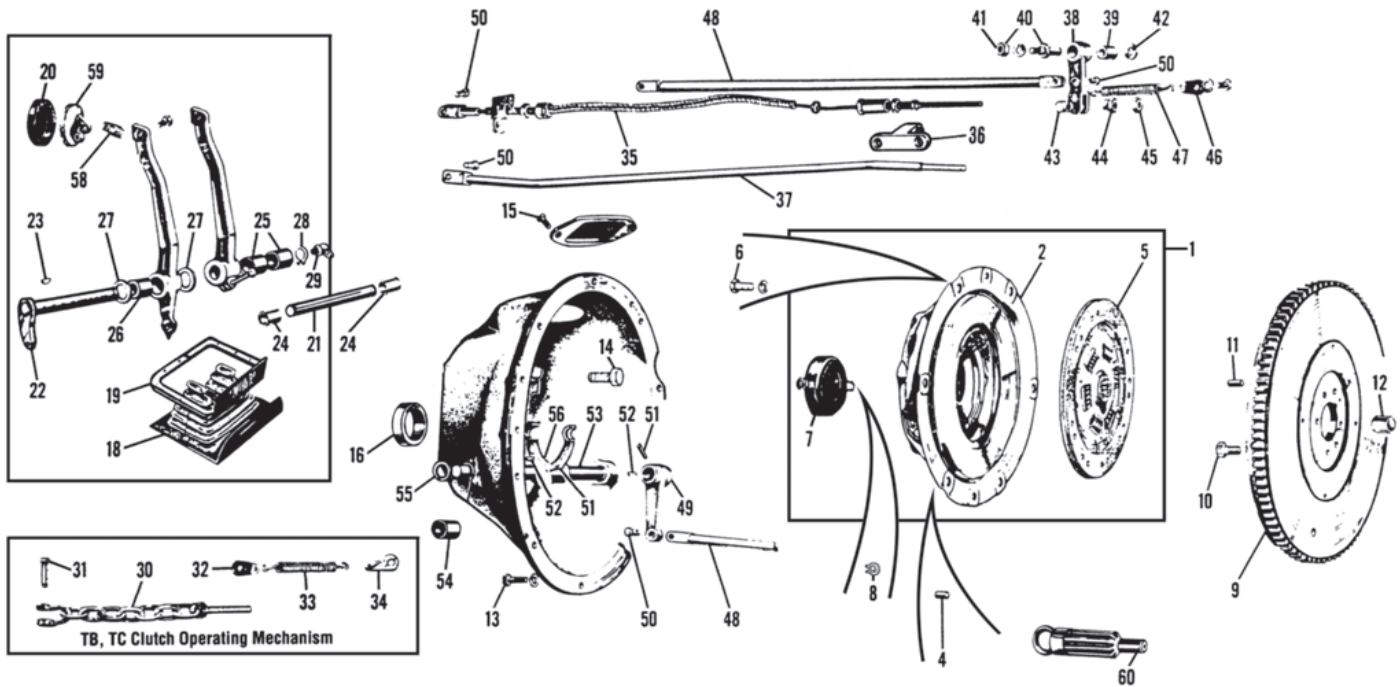

iii. Part Number Price £ea. Description

Clutch System

Clutch Drive, Controls & Fittings

Part Number	Price £ea.	Description	Req.	Details
1 GCK257	£198.00	CLUTCH KIT, 8"	1	TD From (e) 9408, TF
2 GCC114	£156.80	CLUTCH COVER, new, 7 1/4"	1	TB-TC & TD To (e) 9407
GCC108	£140.00	CLUTCH COVER, new, 8"	1	TD From (e) 9408, TF
4 325-318	£1.80	DOWEL SET, clutch cover, (2 dowels)	1	TB-TC-TD & TF
5 PW664A	£159.00	CLUTCH PLATE, reconditioned*	1	TA
GCP148	£55.00	CLUTCH PLATE, new, 7 1/4"	1	TB-TC-TD To (e) 9407
GCP132	£52.00	CLUTCH PLATE, new, 8"	1	TD From (e) 9408, TF

*Note: Customers own unit, please call your nearest Moss branch for details.

6 320-260	£0.86	BOLT, plate to flywheel	6	} TB-TC-TD & TF
7 GRB103	£12.00	RELEASE BEARING	1	
8 7H3048	£1.03	SPRING CLIP, release bearing	2	
9 P162	£42.80	RING GEAR	1	
P163	£42.80	RING GEAR, 10 3/8" ID	1	
P164	£43.10	RING GEAR, 10 3/4" ID	1	
10 320-524	£10.44	BOLT, flywheel to crank	4	
11 325-328	£13.55	DOWEL SET, flywheel to crank, (2 dowels)	1	
12 330-040	£8.50	PILOT BUSH, rear crankshaft	1	
13 321-048	£10.13	BOLT SET, housing to block, (10 bolts)	1	
14 321-058	£8.30	BOLT SET, housing to gearbox, (8 bolts)	1	
15	N/A	SCREW, top cover plate	2	
16 120-200	£11.45	OIL SEAL, clutch housing	1	
AAA5650	£6.00	OIL SEAL, clutch housing	1	
18 280-420	£13.60	FUME EXCLUDER, rubber	1	
19 406-700	£7.70	PLATE, pedal excluder retaining	1	
20 280-440	£2.62	PEDAL PAD, brake & clutch	2	
ACA5359	£1.80	PEDAL PAD, brake & clutch	2	
21 190-480	£18.10	PEDAL SHAFT	1	
22 190-500	£114.65	PEDAL SHAFT, LHD, (as illustrated)	1	
190-560	£33.10	PEDAL SHAFT, RHD	1	
23 327-050	£0.40	KEY, pedal shaft	1	
24 330-050	£7.45	BUSH, pedal	2	
25 330-358	£6.40	BUSH SET, in chassis	1	
26 330-100	£6.30	BUSH, brake & clutch pedal	2	
27 324-430	£7.60	WASHER, pedal spacing	2	
28 326-050	£0.58	CIRCLIP, pedal shaft	2	
29 UHN405	£2.00	GREASE NIPPLE, pedal shaft	1	
30 190-450	£50.70	CHAIN, clutch operating	1	
31 CLZ515	£1.03	PIN, chain to pedal	1	

iii. Part Number Price £ea. Description

32 190-410	£9.00	CLIP, clutch return spring	1	TB & TC
33 329-340	£3.67	SPRING, clutch return	1	}
34 190-470	£17.75	BRACKET, return spring, on starter	1	
35 331-070	£56.40	CLUTCH CABLE	1	TD To (c) 22250
36 190-590	£10.80	BRACKET, cable abutment	1	}
37 451-220	£34.70	CLUTCH ROD, LHD	1	
38 190-400	£36.70	LEVER, (with bush)	1	
39 330-010	£24.00	BUSH, (in lever)	1	
40 190-390	£19.00	FULCRUM PIN, (with nut)	2	
41 AJD8336Z	£0.60	NUT, fulcrum pin	2	
42 324-560	£0.24	WASHER, fulcrum pin	1	
43 190-440	£12.20	BARREL PIN, clutch rod	1	
44 190-430	£17.05	NUT, clutch adjusting	1	
45 AJD8104	£0.34	LOCK NUT, clutch adjuster	1	
46 190-410	£9.00	CLIP, clutch return spring	1	
47 329-330	£10.00	SPRING, clutch return	1	
48 190-422	£42.20	CLUTCH LINK	1	
49 190-370	£72.60	CLUTCH LEVER, 5/8" shaft	1	
190-380	£73.60	CLUTCH LEVER, 3/4" shaft	1	
50 2K6930	£1.30	CLEVIS PIN	3	
51 325-020	£1.60	PIN, clutch lever & fork	2	
52 327-050	£0.40	KEY, 5/8", clutch shaft	2	
WKN606	£1.64	KEY, 3/4", clutch shaft	2	
53 190-320	£63.10	CLUTCH SHAFT, 5/8"	1	
190-330	£52.50	CLUTCH SHAFT, 3/4"	1	
54 330-070	£16.80	BUSH, 5/8", shaft	2	
330-060	£5.40	BUSH, 3/4", shaft	2	
55 326-030	£0.40	CIRCLIP, 5/8", shaft	1	
326-140	£2.87	CIRCLIP, 3/4", shaft	1	
56 190-340	N/A	ACTUATING FORK, 5/8", shaft	1	
190-350	N/A	ACTUATING FORK, 3/4", shaft	1	
58 406-760	N/A	PEDAL PAD EXTENDER	2	
59 406-750	£26.40	ALLOY PEDAL PAD	2	
60 GAC5056	£5.10	CLUTCH ALIGNMENT TOOL	1	
62 406-710	£120.00	BRAKE PEDAL, RHD	1	
63 406-720	£120.00	CLUTCH PEDAL, RHD	1	

Steering Conversion Parts - LHD To RHD, TD & TF

406-770	£102.78	ACCELERATOR PEDAL, RHD	1	}
406-730	£125.00	PEDAL BOX, RHD	1	
406-780	£27.00	CHASSIS TUBE	1	
263-134	£251.00	STEERING RACK, RHD	1	Less track control arms
233-570	£135.00	DASHBOARD FASCIA, plain*	1	}
233-580	£170.70	DASHBOARD BACKING PANEL	1	

'T' Type Lubrication

	Graphite No. 3 (Water Proof) or Semi Fluid Grease	Classic 30 or Classic 40 Multigrade Engine Oil	Cam and Engine Assembly Lube	Running In Oil	Mild EP Hypoid Oil	Gear Oil 40	Hypoid 85W/140	Carburettor Dash Pot Mineral Oil	Trans 140 or Steering Box Lube	Shock Oil for all Piston Type Shock Absorbers	Trans 140 for Luvax Vane Shock Absorbers
Engine Rebuild	Engine Assembly		✓								
	Running In			✓							
500 Mile Intervals	King Pins	✓									
	Steering Ball Joints	✓									
	Road Spring Pins/Trunnions	✓									
	Pedal Shaft	✓									
1000 Mile Intervals	Prop Shaft	✓									
	Carb. Dampers							✓			
	Water Pump										
	Gearbox (top up) TA-TB-TC				✓						
	Gearbox (top up) TD-TF					✓					
	Rear Axle (top up) TA-TB-TC				✓						
	Rear Axle (top up) TD-TF						✓				
3000 Mile Intervals	Engine (refill)	✓									
	Air Cleaner Element	✓									
	Distributor Shaft	✓									
	Dist. Advance Mechanism	✓									
	Distributor Cam	✓									
	Dynamo	✓									
	Steering Box TA-TB-TC								✓		
6000 Mile Intervals	Gearbox (top up) TA-TB-TC				✓						
	Gearbox (top up) TD-TF					✓					
	Rear Axle (top up) TA-TB-TC				✓						
	Rear Axle (top up) TD-TF						✓				
	Rev. Counter Gearbox	✓									
	Handbrake Cables	✓									
	Steering Rack TD-TF	✓									
12000 Mile Intervals	Front Wheel Bearings	✓									
	Road Spring Leaves	✓									
	Shock Absorber (top up) TA										✓
	Shock Absorber (top up) TB-TF								✓		

Part Number Price £ea. Description

Grease

GGL9030X	£7.27	GRAPHITE No. 3 GREASE, 400g
GGL9029X	£7.20	SEMI FLUID GREASE, 500ml
GGL9034X	£4.21	WATER PUMP GREASE, 100g

Engine Oil*

GGL812210	£8.20	CLASSIC 30, (20W/60), 1 litre
GGL812250	£27.60	CLASSIC 30, (20W/60), 5 litre
GGL812310	£7.96	CLASSIC 40, (25W/70), 1 litre
GGL812350	£27.60	CLASSIC 40, (25W/70), 5 litre

Note: These engine oils should be used where the engine has been rebuilt or the condition is known to be good. Non-detergent engine oils are available upon request.

Part Number Price £ea. Description

Gear Oil

GGL824110	£7.94	MILD EP, 1 litre
GGL821210	£7.94	GEAR OIL 40, 1 litre
GGL823210	£7.94	HYPOLID 85W/140, 1 litre
GGL822210	£7.94	TRANSOIL 140, 1 litre
GGL9028X	£7.20	STEERING BOX LUBE, 500ml

Shock Absorber Oil

GGL822210	£7.94	TRANS 140 SHOCK ABSORBER, 1 litre (Trans 140 is for Luvax dampers).
GGL832110	£10.96	SHOCK OIL, 1 litre

Part Number Price £ea. Description

S.U. Carburettor Dashpot Oil

GGL9035X	£4.21	DASHPOT OIL, 125ml
----------	-------	--------------------

Cam & Engine Assembly Lubricant

GGL9031X	£3.50	CAM & ENGINE LUBRICANT, 40g
GGL9122X	£30.60	GRAPHOGEN ASSEMBLY LUB, 125g

Running In Oil

GGL819150	£28.75	RUNNING IN OIL, 5 litre
-----------	--------	-------------------------

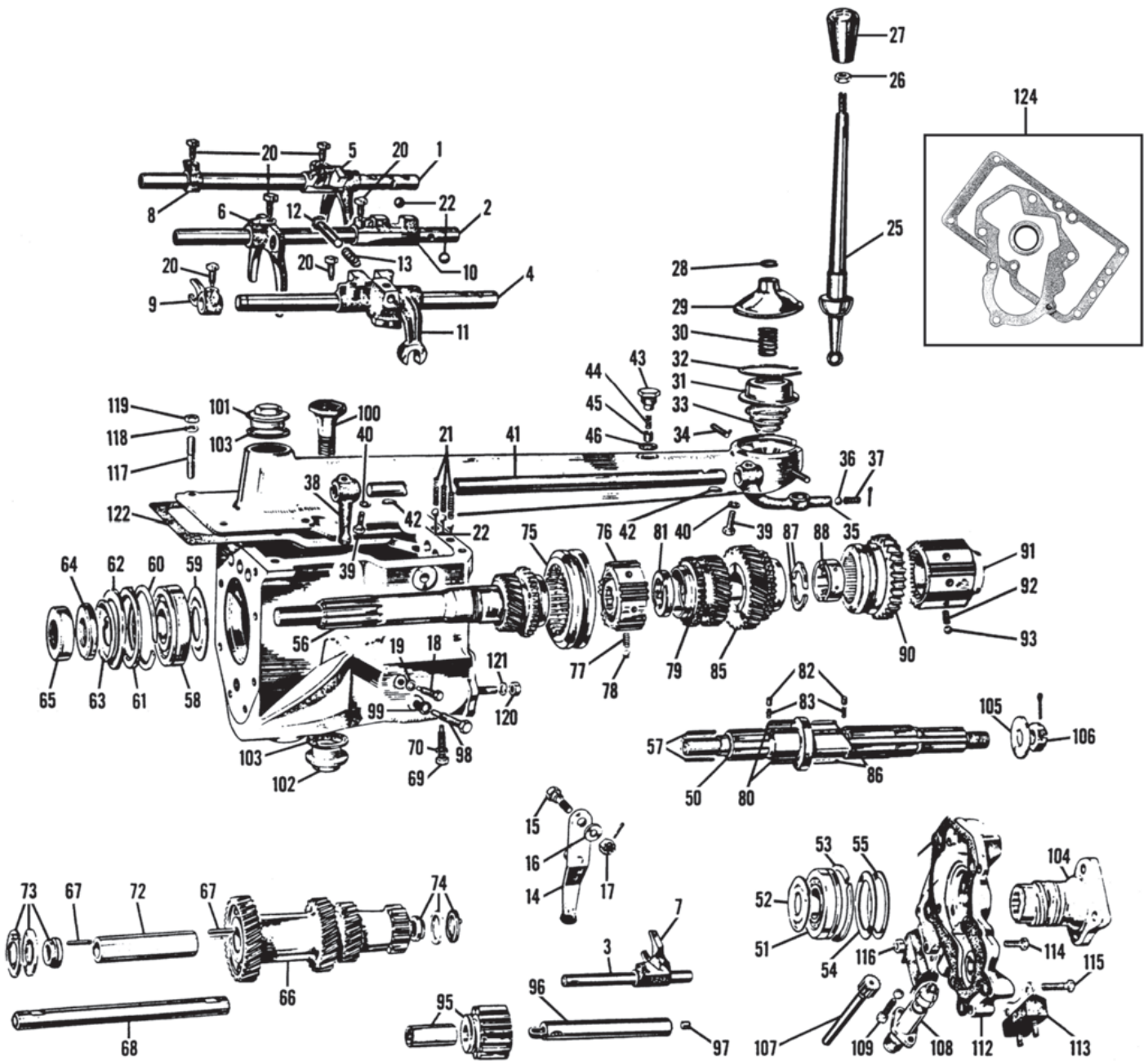

ill. Part Number Price £ea. Description Req. Details

Gearbox Components - TB & TC

Selector Shafts & Forks

1	NCA	SELECTOR SHAFT, 1st & 2nd	1
2	NCA	SELECTOR SHAFT, 3rd & 4th	1
3	NCA	SELECTOR SHAFT, reverse fork	1
4	440-260	SELECTOR SHAFT, reverse	1
5	NCA	FORK, 1st & 2nd gear selector	1
6	NCA	FORK, 3rd & 4th gear selector	1
7	NCA	FORK, reverse selector	1
8	442-020	NCA STOP, 2nd speed	1
9	442-010	NCA STEADY, reverse selector shaft	1
10	NCA	SELECTOR, 3rd & 4th gear	1
11	440-280	NCA SELECTOR, reverse gear	1
12	NCA	PLUNGER, reverse gear selector	1
13	329-190	£2.15 SPRING, reverse gear selector	1
14	NCA	LINK, reverse gear operating	1
15	NCA	FULCRUM PIN, operating link	1
16	NCA	WASHER, fulcrum pin	1
17	NCA	NUT, fulcrum pin	1

ill. Part Number Price £ea. Description Req. Details

18	NCA	LOCK BOLT, reverse fork shaft	1
19	GHF332	£0.19 WASHER, reverse shaft lock bolt	1
20	442-088	£1.60 LOCK BOLT SET, selector & fork	1 (6 lock bolts)
21	329-438	£22.00 SPRING SET, selector shaft	1 (3 springs)
22	329-588	£2.05 BALL SET, selector shafts	1 (5 balls)

Gearbox Extension Components

25	443-055	£75.60 GEAR LEVER	1
26	311-180	£1.44 NUT, gear lever, chrome	1
27	228-290	£15.15 GEAR KNOB, exact reproduction	1
28	NCA	CIRCLIP, gear lever	1
29	443-000	NCA COVER, upper, gear lever	1
30	329-160	£9.76 SPRING, upper, gear lever	1
31	1G3927	NCA COVER, lower, gear lever	1
32	1H3087	£6.70 CIRCLIP, lower, gear lever	1
33	11G3144	£16.25 SPRING, anti-rattle	1
34	AEG3106	£16.35 PIN, gear lever	2
35	443-050	NCA LEVER, actuating shaft	1
36	BLS108	£0.29 BALL, actuating shaft lever	1
37	AEG3123	£1.00 SPRING, actuating shaft lever	1

ill.	Part Number	Price £ea.	Description	Req.	Details
38	443-040	NCA	SELECTOR LEVER	1	
39		NCA	BOLT, selector & actuating shaft lever	2	
40	GHF331	£0.12	WASHER, lever bolt	2	
41	443-150	NCA	OPERATING SHAFT, gear change	1	
42	327-030	£0.97	KEY, operating shaft	2	
43	443-020	£40.00	CAP, operating shaft	1	
44	AE3123	£1.00	SPRING, operating shaft	1	
45	AE3124	NCA	PLUNGER, operating shaft	1	
46	6K638	£0.22	WASHER, operating shaft cap	1	

Mainshaft - Gears & Bearings

50		NCA	MAINSHAFT	1	
51	126-200	£12.60	BEARING, rear mainshaft	1	
52	440-210	NCA	GUARD, rear mainshaft bearing	1	
53		NCA	CIRCLIP, rear mainshaft bearing	1	
54	441-440	£6.90	PLATE, guard	1	
55	441-170	£2.57	SPRING PLATE, guard	1	
56		NCA	FIRST MOTION SHAFT	1	
57	442-248	£62.70	ROLLER BEARING SET, (13 rollers)	1	first motion shaft
58	128-200	£19.50	BEARING, first motion shaft	1	
59		NCA	GUARD, first motion shaft bearing	1	
60		NCA	CIRCLIP, first motion shaft bearing	1	
61		NCA	PLATE, guard	1	
62	848-910	NCA	SPRING PLATE, guard	1	
63		NCA	LOCK WASHER, bearing	1	
64	440-150	NCA	NUT, first motion shaft	1	
65	120-200	£11.45	OIL SEAL, first motion shaft	1	
66		NCA	CLUSTER GEAR	1	
67	442-258	£158.50	ROLLER BEARING SET, (30 rollers)	1	cluster gear
68	440-130	£102.95	SHAFT, cluster gear	1	
69	440-080	NCA	LOCK BOLT, cluster shaft	1	
70	GHF332	£0.19	WASHER, cluster shaft bolt	1	
72		NCA	SPACING TUBE, roller bearing	1	
73	440-110	£92.56	THRUST WASHER ASSEMBLY, front	1	
74	440-120	£88.50	THRUST WASHER ASSEMBLY, rear	1	
75		NCA	SLEEVE ASSEMBLY, 3rd & 4th	1	
76		NCA	SLIDING HUB, 3rd & 4th	1	
77	329-030	£5.70	SPRING, 3rd & 4th sliding hub	6	
78	329-598	£2.15	BALL SET, 3rd & 4th sliding hub	1	(6 balls)
79		NCA	THIRD GEAR	1	
80	442-338	£9.00	ROLLER BEARING SET, third gear	1	(36 rollers)
81	440-180	NCA	LOCK PLATE, third gear	1	
82	442-100	NCA	PLUNGER, 2nd & 3rd gear	2	
83	442-110	£1.33	SPRING, 2nd & 3rd gear	2	
85	440-030	NCA	SECOND GEAR	1	
86	442-228	£118.66	ROLLER BEARING SET, second gear	1	(22 rollers)
87		NCA	SPLIT WASHER, second gear	2	
88		NCA	COLLAR, second gear	1	
90		NCA	FIRST GEAR	1	
91		NCA	SLIDING HUB, 1st & 2nd	1	
92	329-030	£5.70	SPRING, 1st & 2nd sliding hub	6	
93	329-598	£2.15	BALL SET, 1st & 2nd sliding hub	1	(6 balls)
95		NCA	REVERSE GEAR, includes bush	1	
96	442-030	NCA	SHAFT, reverse gear	1	
97		NCA	PLUG, reverse gear shaft	1	
98	440-080	NCA	LOCK BOLT, reverse gear shaft	1	
99	GHF332	£0.19	WASHER, reverse shaft bolt	1	

Gearbox Case Fittings & Mountings

100	440-360	NCA	DIPSTICK	1	
101	442-040	£20.85	PLUG, oil filler	1	
102	442-050	£18.95	PLUG, oil drain	1	
103	6K432	£2.40	WASHER, (copper), drain plug	a/r	oil filler & drain plug
104		NCA	FLANGE, rear	1	
105	324-460	£0.60	WASHER, rear flange	1	
106	311-310	£34.70	NUT, rear flange to mainshaft	1	
107		NCA	PINION, speedometer	1	
108		NCA	HOUSING, speedometer pinion	1	
109		NCA	SCREW, speedometer pinion housing	2	
112	440-320	£210.70	COVER PLATE, rear gearbox	1	
113	410-040	£59.00	MOUNTING, rear gearbox	2	
114	320-680	£2.40	BOLT, mounting to cover, short, (20mm)	2	
115	320-690	£5.05	BOLT, mounting to cover, long, (41mm)	2	
116	311-280	£0.71	NUT, rear mounting bolt	2	
117	328-747	£3.66	STUD, top cover	6	
118	GHF332	£0.19	WASHER, top cover stud	6	
119	311-100	£1.24	NUT, top cover stud	6	
120	311-190	£0.24	NUT, rear cover stud, 10mm	3	
	AJD8106Z	£0.29	NUT, rear cover, 3/8", (BSF)	2	
121	GHF333	£0.19	WASHER, rear cover stud	3	
	GHF332	£0.19	WASHER, rear cover	2	

ill.	Part Number	Price £ea.	Description	Req.	Details
Gaskets					
122	293-700	£6.46	GASKET, top gearbox cover	1	
123	293-800	£3.17	GASKET, rear gearbox cover	1	
124	298-308	£16.60	GASKET & SEAL SET, gearbox	1	(includes front seal)

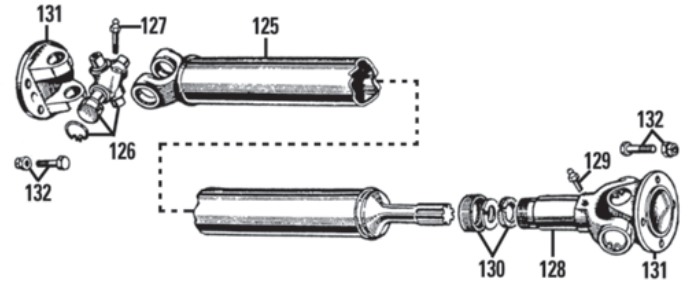

TA-TB & TC Propshaft & Fittings

125	268-015	£212.50	PROPSHAFT	1	
126	GUJ115	£9.30	UNIVERSAL JOINT, greaseable	2	
	GUJ115Z	£8.50	UNIVERSAL JOINT, greaseable	2	aftermarket
127	549229A	£1.64	GREASE NIPPLE, universal joint	2	
128	7H3865	£39.40	YOKE	1	
129	549229A	£1.64	GREASE NIPPLE, yoke	1	
130	7H3880X	£3.60	DUST CAP & CORK SEAL SET, yoke	1	
131	7H3863	£16.00	FLANGE	2	
132	321-338	£9.11	BOLT & NUT SET	2	4 bolts & nuts for 1 flange

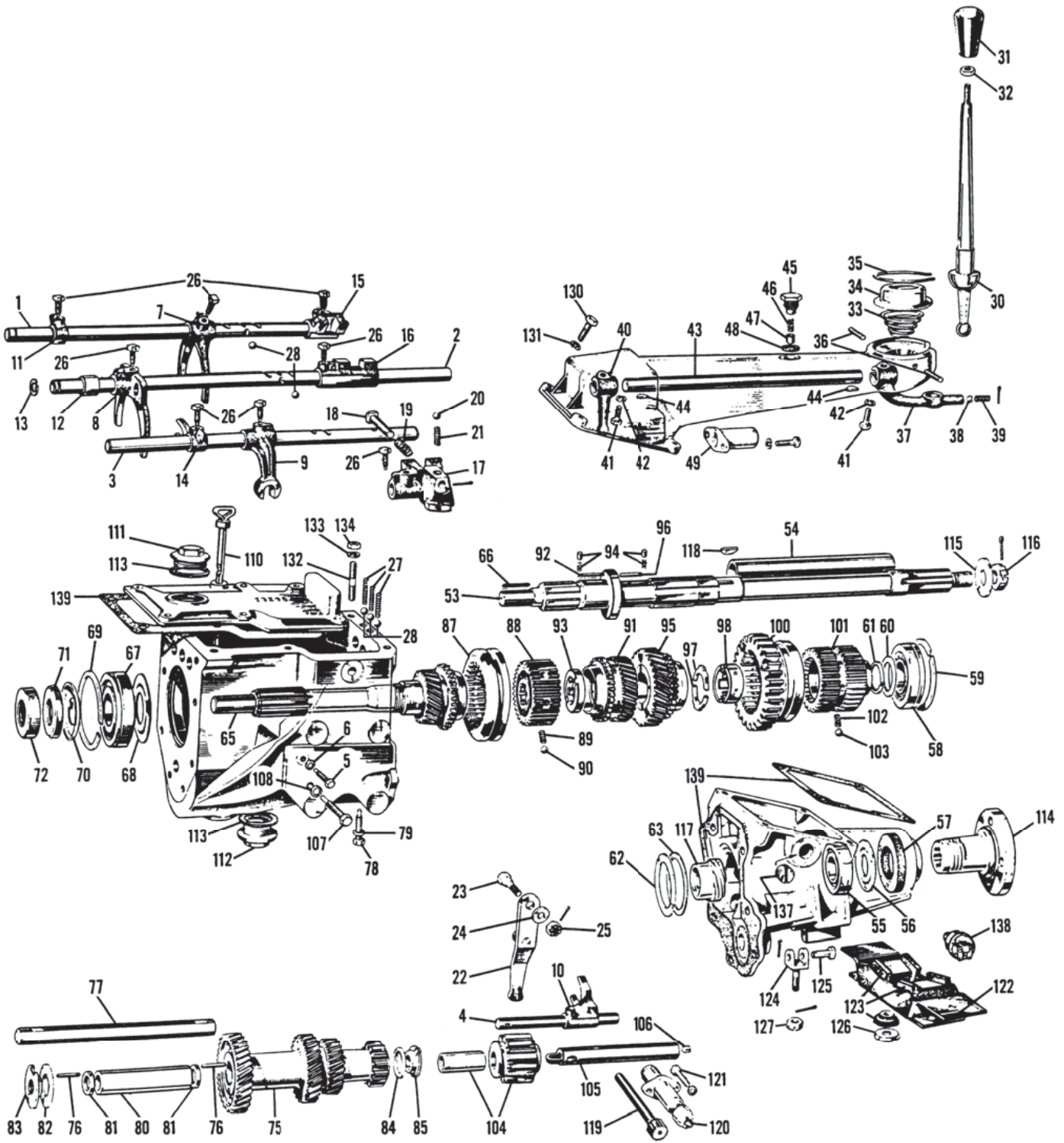

iii. Part Number Price £ea. Description Req. Details

Gearbox Components - TD & TF

Selector Shafts & Forks

1	441-300	£87.40	SELECTOR SHAFT, 1st & 2nd	1
2	441-310	£94.91	SELECTOR SHAFT, 3rd & 4th	1
3	441-320	£60.30	SELECTOR SHAFT, reverse	1
4	441-280	NCA	SELECTOR SHAFT, reverse fork	1
5		NCA	LOCK BOLT, reverse fork shaft	1
6	GHF331	£0.12	WASHER, reverse shaft lock bolt	1
7	441-340	NCA	FORK, 1st & 2nd gear selector	1
8	441-350	NCA	FORK, 3rd & 4th gear selector	1
9	441-360	NCA	FORK, upper reverse gear selector	1
10	441-270	NCA	FORK, lower reverse gear selector	1
11	442-020	NCA	STOP, 2nd speed	1
12	441-330	NCA	SPACER, 3rd & 4th selector shaft	1

iii. Part Number Price £ea. Description Req. Details

13	326-010	£1.50	CIRCLIP, 3rd & 4th selector shaft	1
14	442-010	NCA	STEADY, reverse selector shaft	1
15	441-370	NCA	SELECTOR, 1st & 2nd gear	1
16	441-380	NCA	SELECTOR, 3rd & 4th gear	1
17		NCA	SELECTOR, reverse gear	1
18	441-400	£22.95	PLUNGER, reverse gear selector	1
19	329-190	£2.15	SPRING, reverse selector plunger	1
20	BLS110	£0.29	BALL, reverse gear selector	1
21		NCA	SPRING, reverse gear selector	1
22	441-290	NCA	LINK, reverse gear operating	1
23		NCA	FULCRUM PIN, operating link	1
24		NCA	WASHER, fulcrum pin	1
25		NCA	NUT, fulcrum pin	1
26	442-098	£2.35	LOCK BOLT SET, selector & fork	1 (8 lock bolts)
27	329-040	£2.05	SPRING, selector shaft	3
28	BLS110	£0.29	BALL, selector shaft	5

ill.	Part Number	Price £ea.	Description	Req.	Details
Gearbox Extension Components					
30	443-055	£75.60	GEAR LEVER	1	
31	228-290	£15.15	GEAR KNOB, exact reproduction	1	
32	311-180	£1.44	NUT, gear lever, chrome	1	
33	11G3144	£16.25	SPRING, anti-rattle	1	
34	1G3927	NCA	COVER, gear lever	1	
35	1H3087	£6.70	CIRCLIP, gear lever cover	1	
36	AE3106	£16.35	PIN, gear lever	2	
37	443-050	NCA	LEVER, actuating shaft	1	
38	BLS108	£0.29	BALL, actuating shaft lever	1	
39	AE3123	£1.00	SPRING, actuating shaft lever	1	
40	443-040	NCA	SELECTOR LEVER	1	
41	NCA	NCA	BOLT, selector & actuating shaft lever	2	
42	GHF331	£0.12	WASHER, lever bolt	2	
43	443-010	£39.00	OPERATING SHAFT, gear change	1	
44	327-030	£0.97	KEY, operating shaft	2	
45	443-020	£40.00	CAP, operating shaft	1	
46	AE3123	£1.00	SPRING, operating shaft	1	
47	AE3124	NCA	PLUNGER, operating shaft	1	
48	6K638	£0.22	WASHER, operating shaft cap	1	
49	441-640	NCA	SUPPORT CAP, 3rd & 4th selector shaft	1	TD From (e)16482, TF

Mainshaft - Gears & Bearings

53	451-130	NCA	MAINSHAFT	1	
54	441-430	NCA	DISTANCE PIECE, mainshaft	1	
55	533360A	£12.85	BEARING, rear mainshaft	1	
56	441-180	£8.40	GUARD, rear mainshaft bearing	1	
57	121-300	£5.70	OIL SEAL, rear case, felt	1	
58	AEF137	£17.75	BEARING, centre mainshaft	1	
59	AAA5636	NCA	CIRCLIP, centre mainshaft bearing	1	
60	324-480	£1.80	WASHER, centre mainshaft bearing	1	
61	326-070	£0.82	CIRCLIP, centre mainshaft bearing	1	
62	441-440	£6.90	GUARD PLATE	1	centre mainshaft bearing
63	441-170	£2.57	SPRING PLATE	1	
65	441-060	£357.00	FIRST MOTION SHAFT	1	
66	8G2404	£0.65	ROLLER BEARING, 1st motion shaft	18	
67	AEF135	£19.15	BEARING, first motion shaft	1	
68	441-120	£5.70	GUARD, first motion shaft bearing	1	
69	NCA	NCA	CIRCLIP, first motion shaft bearing	1	
70	441-110	£5.80	LOCK WASHER	1	1st motion shaft bearing
71	441-100	£52.50	NUT, first motion shaft	1	
72	AAA5650	£6.00	OIL SEAL, first motion shaft	1	
75	441-010	£614.00	CLUSTER GEAR	1	
76	442-278	£67.50	ROLLER BEARING SET, cluster gear	1	
	442-260	£5.70	ROLLER BEARING, cluster gear	28	
77	441-250	£60.80	SHAFT, cluster gear	1	
78	441-260	£13.55	LOCK BOLT, cluster shaft	1	
79	GHF331	£0.12	WASHER, cluster shaft bolt	1	
80	441-240	NCA	SPACING TUBE, roller bearing	1	
81	441-230	NCA	WASHER, roller bearing	2	
82	441-190	£24.00	THRUST WASHER, front	1	
83	441-210	£44.20	PLATE, front thrust washer	1	
84	441-200	£24.00	THRUST WASHER, rear	1	
85	441-220	£30.65	PLATE, rear thrust washer	1	
87	441-090	£179.00	SLEEVE ASSEMBLY, 3rd & 4th	1	
88	441-080	£210.70	SLIDING HUB, 3rd & 4th	1	
89	329-200	£7.18	SPRING, 3rd & 4th sliding hub	6	
90	BLS110	£0.29	BALL, 3rd & 4th sliding hub	7	
91	441-040	£153.90	THIRD GEAR	1	
92	442-328	£7.45	ROLLER BEARING SET, (32 rollers)	1	3rd gear
93	NCA	NCA	COLLAR, third gear	1	
94	442-128	NCA	SPRING & PLUNGER SET	2	2nd & 3rd gear (1 of each)
95	441-030	£222.40	SECOND GEAR	1	
96	442-318	£7.20	ROLLER BEARING SET, (28 rollers)	1	
97	441-168	NCA	SPLIT WASHER SET, (2 washers)	1	2nd gear
98	NCA	NCA	COLLAR	1	
100	441-020	£210.70	FIRST GEAR	1	
101	441-070	£189.90	SLIDING HUB, (improved design)	1	1st & 2nd gear
102	329-180	£4.62	SPRING	6	1st & 2nd
103	BLS110	£0.29	BALL	6	sliding hub
104	441-050	£124.00	REVERSE GEAR, (includes bush)	1	
105	442-030	NCA	SHAFT, reverse gear	1	
106	NCA	NCA	PLUG, reverse gear shaft	1	
107	NCA	NCA	LOCK BOLT, reverse gear shaft	1	
108	GHF332	£0.19	WASHER, reverse shaft bolt	1	

Gearbox Case Fittings, Gasket Set & Mountings

110	441-420	NCA	DIPSTICK	1	
111	442-040	£20.85	PLUG, oil filler	1	
112	442-050	£18.95	PLUG, oil drain	1	
113	6K432	£2.40	WASHER, oil filler & drain plug	2	

ill.	Part Number	Price £ea.	Description	Req.	Details
114	NCA	NCA	FLANGE, rear	1	
115	324-460	£0.60	WASHER, rear flange	1	
116	311-310	£34.70	NUT, rear flange to mainshaft	1	
117	NCA	NCA	GEAR, speedometer	1	
118	327-020	£0.82	KEY, speedometer gear	1	TD From (e)16978, TF
119	NCA	NCA	PINION, speedometer gear	1	
120	442-060	NCA	HOUSING, speedometer pinion	1	
121	441-145	£6.20	SCREW, speedometer pinion housing	1	
122	411-020	£66.40	SUPPORT BRACKET, rear mounting	1	
123	281-408	£15.30	MOUNTING SET, gearbox, rubber	1	pair
	280-590	£8.20	MOUNTING, gearbox, rubber	2	single
124	411-030	£31.50	FORK, rear mounting	1	
125	CLZ515	£1.03	CLEVIS PIN, fork	1	
126	324-570	£0.82	WASHER, cupped	1	
127	311-150	£1.99	NUT, rear mounting fork	1	
130	320-290	£0.98	BOLT, remote control cover	4	
131	GHF332	£0.19	WASHER, cover bolt	4	
132	328-747	£3.66	STUD, top cover	6	
133	GHF332	£0.19	WASHER, top cover stud	6	
134	311-100	£1.24	NUT, top cover stud	6	
137	NCA	NCA	PLUG, reverse light switch hole	1	
138	BAU1074A	£6.00	SWITCH, reverse light	1	optional
139	298-418	£9.62	GASKET SET, gearbox	1	

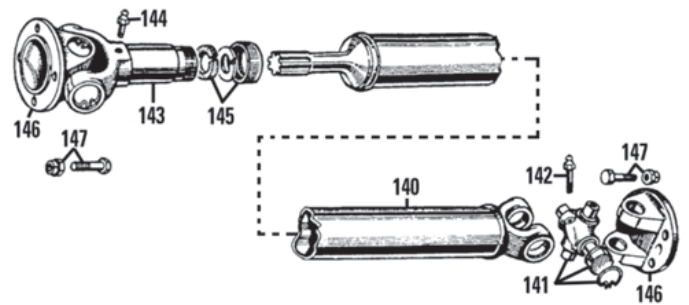

TD & TF Propshaft & Fittings

140	268-025	£153.30	PROPSHAFT	1	
141	GUJ115	£9.30	UNIVERSAL JOINT, greaseable	2	
	GUJ115Z	£8.50	UNIVERSAL JOINT, greaseable	2	aftermarket
142	7H3858	£1.85	GREASE NIPPLE, universal joint	1	
143	7H3865	£39.40	YOKE	1	
144	549229A	£1.64	GREASE NIPPLE, yoke	1	
145	7H3880X	£3.60	DUST CAP & CORK SEAL SET, yoke	1	
146	7H3863	£16.00	FLANGE	2	
147	321-338	£9.11	BOLT & NUT SET	2	4 bolts & nuts for 1 flange

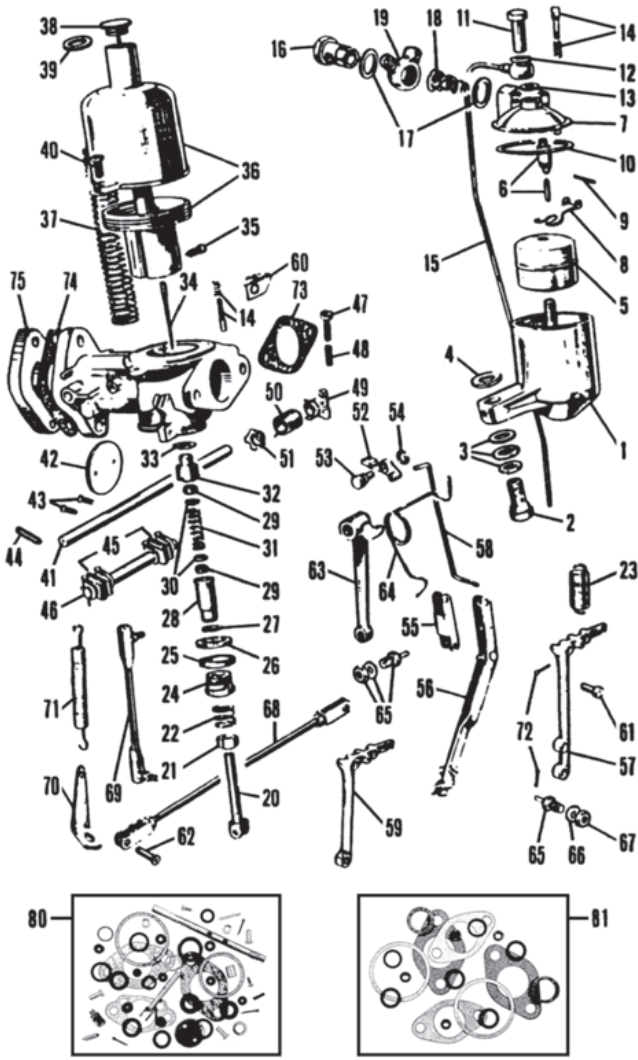

Part Number	Price £ea.	Description	Req.	Details
22	£1.64	SPRING, jet adjusting nut	2	
23	£4.27	SPRING, jet return	2	
24	£4.84	NUT, jet securing	2	
25	£3.76	WASHER, jet securing nut	2	
26	£0.60	GASKET, jet securing nut*†	2	
27	£3.22	WASHER, bottom jet bearing, copper*	2	
28	£19.80	BEARING, bottom jet	2	
29	£0.94	JET SEAL*†	4	
30	£1.85	WASHER, jet seal, brass*	4	
31	£2.84	SPRING, jet	2	
32	£11.70	BEARING, top jet	2	
33	£0.53	WASHER, top jet bearing, copper*	2	
34	£10.00	JET NEEDLE, (AC), standard	2	TA 1 1/4", carburettors
AUD1166	£9.50	JET NEEDLE, (ES), standard	2	TB-TC & TD 1 1/4", carbs.
AUD1258	£10.00	JET NEEDLE, (LS1), standard	2	TD MkII 1 1/2", carbs.
AUD1214	£9.50	JET NEEDLE (GJ), standard	2	TF 1 1/2", carburettors
AUD1046	£10.00	JET NEEDLE, weak	2	all models
35		NCA SCREW, jet needle retaining	2	
36		NCA CHAMBER ASSEMBLY, 1 1/4", carbs.	2	TB-TC & TD
		NCA CHAMBER ASSEMBLY, 1 1/2", carbs.	2	TD MkII & TF
37	£3.50	SPRING, piston, (if fitted)	2	
38	£22.80	CAP & DAMPER, round brass cap	2	
AUC8103A	£14.80	CAP & DAMPER, *plastic cap	2	TB-TC & TD
*Note: Alternative to original brass cap.				
AUC8102HB	£19.85	CAP & DAMPER, hexagon brass cap	2	
AUC8102A	£16.15	CAP & DAMPER, *plastic cap	2	TD MkII & TF
*Note: Alternative to original brass cap.				
39	£0.40	WASHER, piston damper	2	
40	£2.87	SCREW, chamber to body, brass	4/6	(1 1/4" carbs use 4)
41	£18.00	THROTTLE SHAFT, standard	2	TB-TC & TD 1 1/4" carbs.
AUC3242	£14.20	THROTTLE SHAFT, standard	2	TD MkII & TF 1 1/2" carbs.
376-020	£18.00	THROTTLE SHAFT, oversize	2	TB-TC & TD 1 1/4" carbs.
AUC3242RP	£14.20	THROTTLE SHAFT, oversize	2	TD MkII & TF 1 1/2" carbs.
42	£16.10	DISC, throttle	2	TB-TC & TD 1 1/4" carbs.
WZX1323	£11.70	DISC, throttle	2	TD MkII & TF 1 1/2" carbs.
43	£0.72	SCREW, throttle disc	4	
44		NCA PIN, levers to throttle shaft	2	
45	£37.90	COUPLING KIT, throttle shaft	1	inc. coupling rod & couplers
46	£16.20	COUPLING ASSEMBLY	2	
47	£0.80	SCREW, idle adjustment	3	
48	£0.94	SPRING, idle adjustment	3	
49	£9.67	CLIP, retaining	2	
50	£6.60	SPRING, rear	1	late TC-TD & TF
AUC4782	£6.60	SPRING, front	1	
51	£20.10	ANCHOR, spring	2	
52	£25.50	LEVER, fast idle	1	
53	£5.34	PIVOT BOLT, fast idle lever	1	TD & TF
54	£2.65	WASHER, pivot bolt	1	
55	£23.90	LINK, jet lever to carburettor	2	TB & TC
56	£10.80	LINK, rear jet lever to carburettor	1	TD & TF
57	£45.00	JET LEVER, rear	1	TB & TC
AUC3234	£23.10	JET LEVER, rear	1	TD & TF
58	£11.04	LINK, fast idle	1	
59	£79.80	JET LEVER, front	1	TB & TC
AUC3346		NCA JET LEVER, front	1	TD & TF
60	£14.35	ANCHOR CLIP, slow-running control	1	TB & TC
61	£1.85	CLEVIS PIN, short	a/r	
62	£2.35	CLEVIS PIN, long	a/r	
63	£169.00	LEVER, slow-running	1	TB & TC
64	£4.94	SPRING, slow-running	1	
65	£1.80	CABLE STOP SET, slow-run & choke	1/2	
66	£0.30	WASHER, plain	1/2	TB & TC, (TC uses 2)
67	£0.12	NUT	1/2	
68	£22.00	LINK, between jet levers	1	
69	£46.00	LINK, throttle	1	
70	£22.95	BRACKET, throttle spring, on starter	1	TB-TC-TD & TF
71	£9.62	SPRING, throttle return	1	
72	£0.82	SPLIT PIN SET, (8 pins)*	1	
73	£1.55	GASKET, carburettor to filter*†	2	TB-TC & TD
12G2125	£0.29	GASKET, carburettor to filter*†	2	TD MkII & TF
74	£0.41	GASKET, carburettor to manifold*†	2	TA-TB-TC & TD
AEH551	£0.70	GASKET, carburettor to manifold*†	2/4	TD MkII & TF, (TF uses 4)
75	£5.00	SPACER, carburettor	2	TF
Note: Rebuild kits also include a jet adjustment spanner as well as all items marked ().				
†Note: Gasket kits include all items marked (†). All our kits service two carburettors				
80	£54.50	REBUILD KIT, carburettor, 1 1/4" carb.	2	TB-TC & TD
	£103.00	REBUILD KIT, carburettor, 1 1/2" carb.	1	TD MkII
	£108.00	REBUILD KIT, carburettor, 1 1/2" carb.	1	TF
81	£18.80	GASKET SET*	1	TB & TC
	£15.85	GASKET SET*	1	TD
	£17.35	GASKET SET*	1	TD MkII & TF

Part Number	Price £ea.	Description	Req.	Details
NI		NCA CARBURETTORS, new, (pair)	1	TA, (brass piston)
NI AUC429T	£990.00	CARBURETTORS, new, (pair)*	1	TB & TC
NI AUC549T	£900.00	CARBURETTORS, new, (pair), 11/4**	1	TD
NI AUC728T	£1,112.00	CARBURETTORS, new, (pair), 11/2**	1	TD MkII & TF

Carburettors & Fittings (All Models)

*Note: Our Brand New (non-exchange) carbs are supplied in matched pairs, less linkage.

1	AUC3495	£139.20	FLOAT BOWL, front	1	TB-TC-TD & TF
	AUC3496	£139.20	FLOAT BOWL, rear	1	
2	AUC1541	£9.37	BOLT, float bowl to carburettor	2	
3	AUE6	£2.15	WASHER SET, float bowl bolt*	2	(3 washers)
4	AUC2130	£1.34	WASHER, bowl to carburettor, fibre*	2	
5	WZX1303	£14.40	FLOAT	2	
6	WZX1101A	£9.00	NEEDLE & SEAT*	2	
	GAC9201X	£9.50	GROSE-JET	2	(Grose-Jets are a superior replacement for the original type needle & seat).
7	AUE479	£54.50	COVER SET, front, (includes lever)	1	TB-TC-TD & TF
	AUE478	£54.50	COVER SET, rear, (includes lever)	1	
8	AUC1980	£11.90	LEVER, float bowl cover	2	original cover
9	AUC1152	£0.60	PIN, lever*	2	
10	AUC1147A	£1.03	GASKET, float bowl cover*†	2	
11	AUC1867X	£4.88	CAP NUT, float bowl cover	2	
12	AUC1557	£0.82	WASHER, cover bolt, aluminium*	2	
13	AUC1928	£1.55	WASHER, cover bolt, fibre*	2	
14	WZX1105	£6.00	PIN & SPRING ASSEMBLY, brass	2/4	1 1/2" carburettor uses 4
15	AUC1866	£13.05	OVERFLOW PIPE	2	
16	AUC2698	£2.90	BANJO BOLT, petrol pipe	2	
17	AUC2141	£0.40	WASHER, banjo bolt, fibre*	4	
18	AUC2139	£4.42	SCREEN, petrol filter	2	
19	AUC1832	£13.80	BANJO, petrol pipe	1/2	MkII uses 2
20	AUC8182	£12.60	JET*, 0.090"	2	
21	AUC2121	£3.35	NUT, jet adjusting	2	

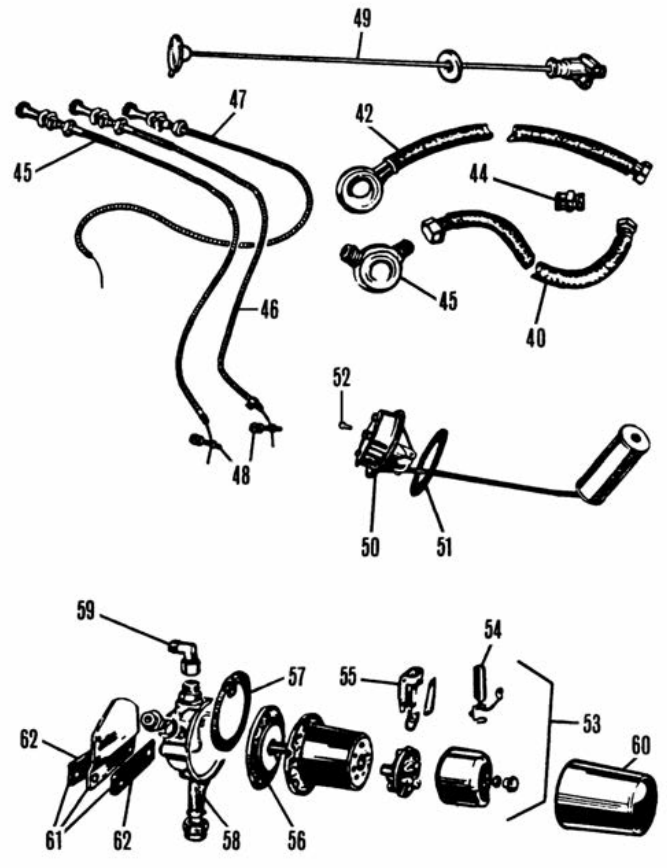
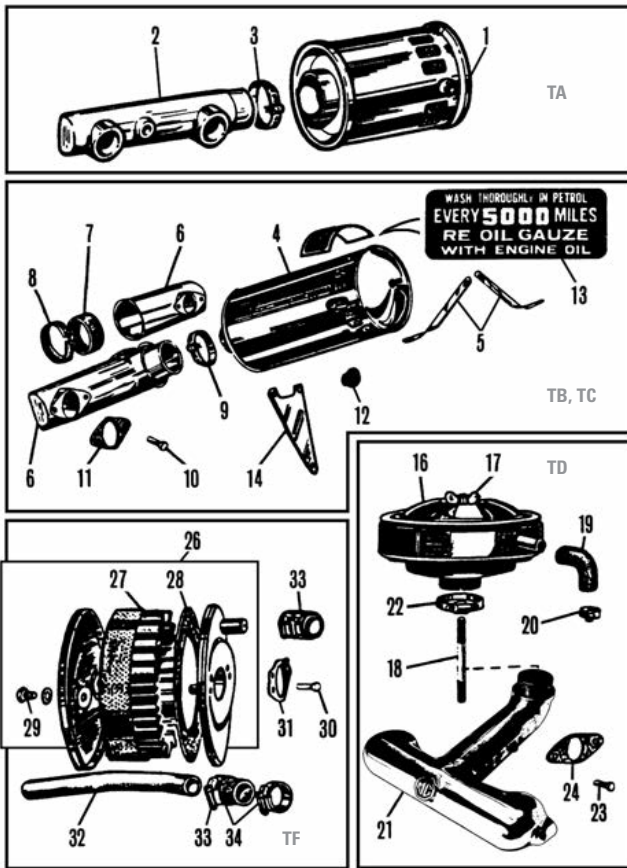

iii. Part Number Price £ea. Description Req. Details

Air Cleaners & Fittings (All Models)

1	372-490	NCA	AIR CLEANER CANISTER	1	TA	
2	372-495	£107.95	AIR CLEANER MANIFOLD	1		
3	CS4038	£1.85	CLAMP, manifold to canister	1		
4	372-150	£175.00	AIR CLEANER CANISTER	1	TB & TC	
5	370-918	£37.90	BRACKET SET, mounting, (2 brackets)	1		
6	372-145	£174.00	MANIFOLD SET, air inlet	1		
7	280-175	£12.85	COLLAR, air inlet manifold	1		
8	372-155	£30.50	CLAMP, inlet manifold collar	1		
9	CS4038	£1.85	CLAMP, manifold to canister	1		
10	320-290	£0.98	BOLT, carburettor to air cleaner	4		
11	294-600	£1.55	GASKET, carburettor to air cleaner	2		
12	280-160	£1.60	GROMMET, filter to rocker cover	1		
13	CRST253	£3.50	AIR FILTER DECAL	1		
14	370-900	£41.20	BRACKET, starter & choke cable	1		
16	373-225	£195.00	AIR CLEANER CANISTER	1		TD
17	373-340	£4.78	WING NUT, air cleaner stud	1		
18	373-350	NCA	STUD, air cleaner mounting	1		
19	280-180	£4.70	ELBOW, filter to rocker cover, rubber	1		
20	326-260	£2.77	CLAMP, rubber elbow	2		
21	373-335	£212.80	MANIFOLD, air inlet	1		
22	GHC11055	£2.65	CLAMP, manifold to cleaner	1		
23	320-290	£0.98	BOLT, carburettor to air cleaner	4		
24	294-600	£1.55	GASKET, carburettor to air cleaner	2		
	12G2125	£0.29	GASKET, carburettor to air cleaner	2		
26	372-165	£168.90	AIR CLEANER SET, front & rear	1	TD MkII	
	372-167	£123.11	CASE, air filter	2		
27	372-175	£21.00	ELEMENT, air cleaner	2	TF	
28	AHH5441K	£13.20	FELT PAD	4		
29	320-360	£0.80	BOLT, carburettor to air cleaner	4		
30	320-360	£0.80	BOLT, air cleaner	4		
31	12G2125	£0.29	GASKET, carburettor to air cleaner	2		
32	372-020	£18.30	BREATHER PIPE, air cleaner	1		
33	12B703	£1.20	HOSE SET, breather pipe, (2 hoses)	1		
34	MM326-250	£1.64	CLAMP, breather pipe hose	4		

iii. Part Number Price £ea. Description Req. Details

Fuel Pump/Hoses & Control Cables (All Models)

Note: See the Accessories section for performance & tuning. Our Flexible fuel hoses are braided Stainless Steel with a non-ageing Teflon interior, and they are guaranteed for life.

40	376-090	£18.05	FUEL HOSE, pump to carburettor 18**	1	TB-TC & TD MkII
	AAA294	£20.15	FUEL HOSE, pump to carburettor 16**	1/3	TA-TD (MkII uses 3) & TF
42	376-055	NCA	FUEL HOSE, carb. to carburettor, 8**	1	TA
	376-080	£16.90	FUEL HOSE, carb. to carburettor, 14**	1	TB-TC & TD
	ACH8977	£14.10	FUEL HOSE, carb. to carburettor, 16**	1	TF

*Note: Braided stainless steel.

43	376-300	£22.95	UNION, fuel pipe	1	TD MkII
44	AUC1832	£13.80	BANJO, fuel pipe	1/2	TD MkII uses 2
45	MM331-390	£51.80	SLOW-RUNNING CABLE	1	TA-TB & TC
46	331-380	£58.00	CHOKE CABLE	1	TA-TB & TC
	331-290	£34.70	CHOKE CABLE	1	TD
	331-410	£41.20	CHOKE CABLE	1	TF
47	331-370	£76.90	STARTER CABLE	1	TA-TB & TC
	331-280	£30.65	STARTER CABLE	1	TD
	331-400	£33.30	STARTER CABLE	1	TF
48	ACC5062K	£1.80	CABLE STOP	1/2	TA-TB & TC use 2
49	360-060	NCA	FUEL RESERVE TAP	1	TA & TB
50	360-050	£37.40	FUEL TANK FLOAT UNIT	1	2 piece
	293-401	£7.05	GASKET SET, top cover & mounting	1	
51	2H1082	£0.38	GASKET, float unit	1	
52	323-728	£3.22	SCREW SET, float unit to tank	1	screw set inc. 6 screws
53	AUA25	£115.00	FUEL PUMP, SU	1	TA, TB, TC, TD,
	AUA25B	£296.30	FUEL PUMP, SU, brass body	1	& TF to (c) 1509
	AZ1331	£110.00	FUEL PUMP, SU	1	TF From (c) 1510
54	CZX1004	£8.34	DIODE, negative earth	1	rear mounting
	CZX1005	£9.56	DIODE, positive earth	1	alternatives
55	AUB6113	£11.40	POINT SET, SU, single point	1	
	AUB106A	£11.00	POINT SET, SU, twin point	1	all models
56	WZX1710	£28.00	DIAPHRAGM, fuel pump	1	
57	AUA4082	£1.03	GASKET, fuel pump body	1	
58	AUA1464	£7.27	FILTER SCREEN, fuel pump	1	
59	MM375-038	£14.10	ELBOW, fuel pump outlet	1	
60	ACG5147	£8.15	RUBBER BOOT, weather protection	1	
61	377-278	£28.30	MOUNTING KIT, fuel pump	1	
	AAA1477K	£21.00	MOUNTING KIT, fuel pump	1	
	377-268	NCA	MOUNTING KIT, fuel pump	1	
62	AAA260C	£2.62	PAD SET, fuel pump mounting	1	

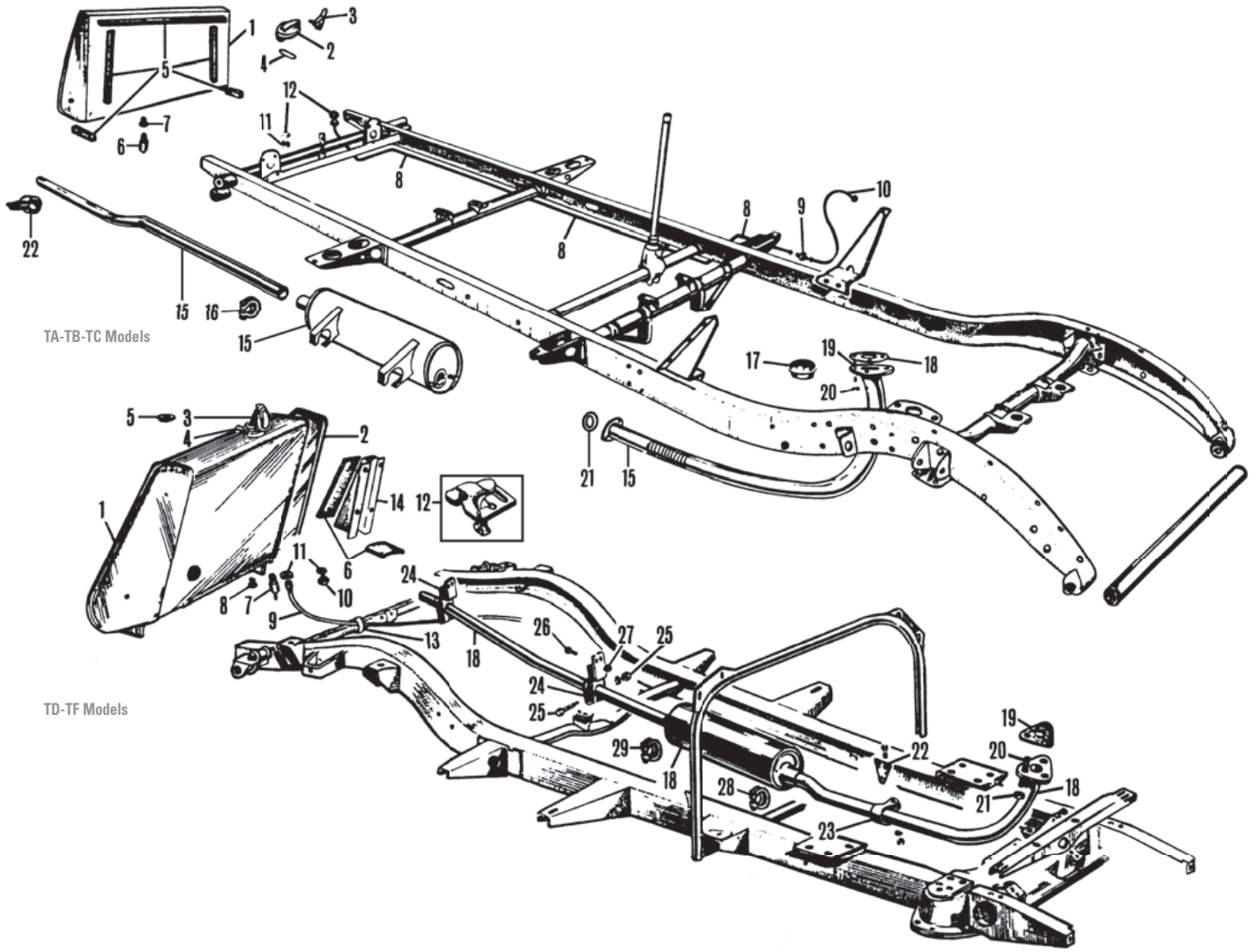

Part Number	Price £ea.	Description	Req.	Details
Fuel Tank, Pipes & Exhaust Systems				
Fuel Tank & Pipes, TA, TB & TC				
1	456-760	£486.00 FUEL TANK	1	TA To (c) 1090
	456-765	£486.00 FUEL TANK	1	TA From (c) 1091 & TB
	456-770	£486.00 FUEL TANK	1	TC
2	407-090	£77.10 FUEL CAP, original type, reproduction	1	
3	407-105	£19.75 RELEASE CLIP, fuel cap	1	
4	293-500	£2.24 GASKET, fuel cap	1	
5	280-928	£63.10 PAD SET, fuel tank to frame	1	(5 rubber pieces)
6	376-665	£29.50 FUEL LINE ADAPTOR, with filler	1/2	TA & TB (TB uses 2)
7	378-520	NCA FILTER SCREEN	1	(solder into fuel tank adaptor)
8	376-770	£82.85 FUEL PIPE, tank to union	1	
9	376-300	£22.95 UNION, (between fuel pipes)	1	
10	376-780	£45.20 FUEL PIPE, union to pump	1	
11	AEK122	£8.00 DRAIN PLUG, fuel tank	1	
12	AUC2141	£0.40 WASHER, fuel pipe & drain plug	2	
Fuel Tanks & Pipes, TD & TF				
1	456-785	£486.00 FUEL TANK	1	TD
	456-795	£486.00 FUEL TANK	1	TF
2	451-648	£178.80 END PANEL SET, fuel tank	1	TD (2 chrome panels)
	451-658	£172.20 END PANEL SET, fuel tank	1	TF (2 chrome panels)
3	407-090	£77.10 FUEL CAP	1	TC type
4	407-105	£19.75 RELEASE CLIP, fuel cap	1	
5	293-600	£2.10 GASKET, fuel cap	1	for original cap
6	281-798	£16.80 PAD SET, fuel tank to chassis	1	4 rubber pads
7	376-665	£29.50 ADAPTOR, fuel pipe, inc. filter	1	
8	378-520	NCA FILTER SCREEN	1	(Screen must be soldered into fuel tank adaptor).
9	454-080	£53.40 FUEL PIPE, tank to pump	1	TD & TF To (e) 1509
	454-075	NCA FUEL PIPE, tank to 2nd pump	1	TD MkII

Part Number	Price £ea.	Description	Req.	Details
454-085	£21.45	FUEL PIPE, tank to pump	1	TF From (e) 1510
454-095	£32.50	FUEL PIPE, pump to front fuel pipe	1	
10	AEK122	£8.00 DRAIN PLUG, fuel tank	1	
11	AUC2141	£0.40 WASHER, fuel pipe & drain plug	2	
12	326-326	£4.05 CHASSIS CLIP, fuel & brake pipe	10	original type
13	ACH8650	£1.90 STRAP, fuel & brake pipes	6	
14	449-595	£35.60 BRACKET, tank to body support	2	TD
	449-600	£30.40 BRACKET, tank to body support	2	TF
N1	454-080	£53.40 FUEL PIPE, tank to pump	1	TD & TF To (e) 1509
	454-075	NCA FUEL PIPE, tank to 2nd pump	1	TD MkII
Exhaust System, TA, TB & TC (Stainless Steel)				
Note: Mild steel systems are no longer available.				
15	454-518	£254.00 EXHAUST SYSTEM (Includes silencer, front & rear pipes).	1	TA (original engine only)
	454-508	£264.00 EXHAUST SYSTEM (Includes silencer, front & rear pipes).	1	TB & TC
	FSMG393	£83.45 FRONT PIPE, stainless steel	1	
	FSMG395	£136.50 SILENCER, stainless steel	1	TA
	FSMG396	£34.70 TAIL PIPE, stainless steel	1	
	FSMG394	£82.50 FRONT PIPE, stainless steel	1	
	FSMG395	£136.50 SILENCER, stainless steel	1	TB & TC
	FSMG396	£34.70 TAIL PIPE, stainless steel	1	
16	GEX9003	£0.55 CLAMP, tail pipe to silencer	1	
17	433-320	£10.50 CUPPED WASHER, exhaust flange	1	
18	290-500	£7.50 GASKET, pipe to manifold	1	
19	328-828	£6.90 STUD SET, exhaust flange, 3 studs	1	
20	311-768	£5.54 NUT SET, exhaust flange, 3 nuts	1	
21	293-100	£4.43 GASKET, original pipe to silencer	1	
22	412-060	£16.35 BRACKET, original tail pipe to chassis	1	

*Note: See the Accessories section for performance & tuning.

ill. Part Number Price £ea. Description Req. Details

Exhaust System, TD & TF (Stainless Steel)

Note: Mild steel exhaust systems are no longer available.

18	454-538	£150.20	EXHAUST SYSTEM (Includes silencer, front & rear pipes).	1	
	FSMG594	£38.40	FRONT PIPE, stainless steel	1	
	FSMG595	£112.67	SILENCER, stainless steel	1	
	FSMG596	£31.50	TAIL PIPE, stainless steel	1	
19	290-500	£7.50	GASKET, pipe to manifold	1	
20	328-808	£8.24	STUD SET, 3 studs	1	exhaust flange
21	311-768	£5.54	NUT SET, 3 nuts	1	
22	412-010	£34.70	BRACKET, front exhaust pipe	1	on gearbox
23	412-070	£19.80	CLAMP, front pipe to bracket	1	
24	412-040	£15.10	HANGER, tailpipe securing	2	
25	321-678	£1.03	BOLT & NUT SET, tailpipe hanger	2	1 of each
26	AJD6155Z	£0.70	BOLT, tailpipe hanger securing	4	
27	AJD8104	£0.34	NUT, for hanger bolt	4	
28	GEX9008	£0.60	CLAMP, front pipe to silencer	1	
29	GEX9007	£0.70	CLAMP, tail pipe to silencer	1	

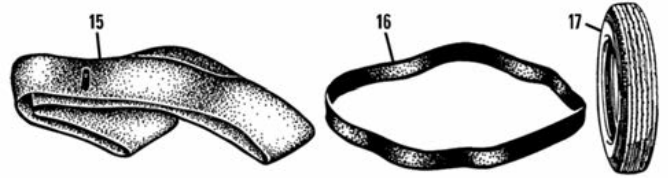

ill. Part Number Price £ea. Description Req. Details

13	AHH5839	£5.90	SPANNER, for octagonal wheel spinner	1	
14	MM385-800	£9.50	SPOKE SPANNER	1	
15	454-410	£33.60	INNER TUBE, 19" x 4.50	a/r	
	454-420	£31.50	INNER TUBE, 15" x 5.50	a/r	
	452-755	£12.60	INNER TUBE, 15" x 165 tyre	a/r	
	452-765	£20.90	INNER TUBE, 15" x 185 tyre	a/r	
	452-785	£47.20	INNER TUBE, 19" x 4.5, heavy duty	a/r	
16	452-750	£10.60	RIM BAND, 15"	a/r	
	452-760	£14.65	RIM BAND, 19"	a/r	
17	454-700	£192.50	TYRE, Dunlop B5, 450 x 19"	a/r	
	454-710	NCA	TYRE, Dunlop, 5.50 x 15"	a/r	
18	CCWP1	£15.00	WHEEL PAINT, silver	a/r	

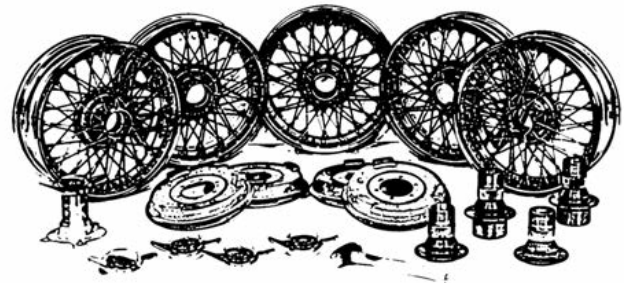
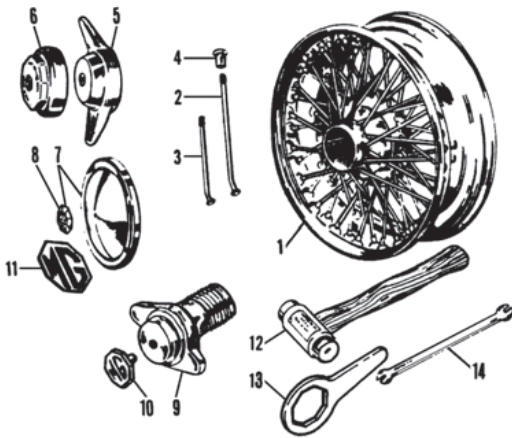
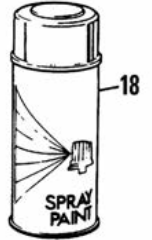

Road Wheels

Note: See the Accessories section for further details on road wheels and range of wheel tools.

1	454-607	£323.00	WIRE WHEEL, painted	5	TA To (c) 1769, outer laced 19"
	454-600	£284.00	WIRE WHEEL, painted	5	TA From (c) 1770,
	454-795	£384.40	WIRE WHEEL, chrome	5	TB & TC & centre laced 19"
	WWP450	£154.80	WIRE WHEEL, painted, 15" x 4"	5	48 spoke wheel
	WWC450	£211.00	WIRE WHEEL, chrome, 15" x 4"	5	
	WWP452	£154.20	WIRE WHEEL, painted, 15" x 4.5"	5	60 spoke wheel
	WWC452	£222.20	WIRE WHEEL, chrome, 15" x 4.5"	5	
2	200-010	£8.03	SPOKE, outer/long, mild steel	a/r	TA, TB & TC centre laced 40 spoke 19"
	200-020	£3.82	SPOKE, inner/short, mild steel	a/r	TA, TB & TC centre laced 40 spoke 19"
3	7H1805	£3.90	SPOKE, outer/long, mild steel	a/r	48 spoke painted
	7H1806	£3.91	SPOKE, inner/short, mild steel	a/r	wire wheels
	7H1805CP	£7.12	SPOKE, outer/long, chrome stainless	a/r	48 spoke chrome
	7H1806CP	£7.12	SPOKE, inner/short, chrome stainless	a/r	wire wheels
	17H8619	£3.82	SPOKE, outer/long, mild steel	a/r	60 spoke painted
	17H8620	£3.91	SPOKE, inner/short, mild steel	a/r	wire wheels
	17H8619CP	£7.12	SPOKE, outer/long, chrome stainless	a/r	60 spoke chrome
	17H8620CP	£7.52	SPOKE, inner/short, chrome stainless	a/r	wire wheels
4	7H1709	£0.40	NIPPLE, mild steel	a/r	painted wire wheels
	37H3651	£1.64	NIPPLE, chromed stainless	a/r	chrome wire wheels
5	AHH7317A	£23.80	WHEEL SPINNER, 2-eared, RH	2	
	AHH7318A	£23.80	WHEEL SPINNER, 2-eared, LH	2	with MG motif
6	AHH7315A	£24.00	WHEEL SPINNER, octagonal, RH	2	
	AHH7316A	£24.00	WHEEL SPINNER, octagonal, LH	2	
7	ACH8304	£25.00	HUB CAP, includes medallion	5	TD & TF
	200-235	£21.00	HUB CAP, (drilled), less medallion	5	TD & TF, (not drilled)
8	200-277	£6.60	MEDALLION, hub cap	5	TD & TF
9	200-250	£79.30	WHEEL SPINNER, spare wheel	1	TA, TB & TC
	200-260	£80.30	WHEEL SPINNER, spare wheel	1	TF
10	AAA523	£44.20	MEDALLION, spare wheel	1	TA-TB & TC, brown & cream
	ARH900	£23.00	MEDALLION, spare wheel, wire	1	TF & black & white
	AAA5021	£36.90	MEDALLION, spare wheel, steel	1	
11	AAA5021	£36.90	MEDALLION, spare wheel, steel	1	
12	C27290	£25.00	WHEEL HAMMER, copper/hide	1	2lbs
	11B5166	£25.00	WHEEL HAMMER, copper/copper	1	1.5lbs

Wire Wheel Conversion Kits For TD & TF Models

The following wire wheel conversion kits are designed to convert your disc wheeled TD or TF to wire wheels. Each kit includes four splined hubs, four brake drums, one spare wheel adaptor with spinner (to convert spare wheel carrier to wire wheels), and all the studs, nuts, etc. for an easy installation. These kits will enhance the appearance of any TD and are identical to the original factory option for the TF.

Note: Our conversion kits do not include wheel or spinners.

111-518	£790.00	WIRE WHEEL CONVERSION KIT	1	TD-TF
AHH7317A	£23.80	WHEEL SPINNER, 2-eared, RH	2	with MG motif
AHH7318A	£23.80	WHEEL SPINNER, 2-eared, LH	2	
AHH7315A	£24.00	WHEEL SPINNER, octagonal, RH	2	
AHH7316A	£24.00	WHEEL SPINNER, octagonal, LH	2	
WWP450	£154.80	WIRE WHEEL, painted	5	15" 48 spoke
WWC450	£211.00	WIRE WHEEL, chrome	5	
WWP452	£154.20	WIRE WHEEL, painted	5	15" 60 spoke
WWC452	£222.20	WIRE WHEEL, chrome	5	

Note: See the Restoration Tools catalogue for further details of roadside tools.

Vintage Screw-Jack

These vintage screw-jacks are identical to the factory originals. Ideal not only for jacking up your T type, but also for holding that wayward garage door open!



NI	AHH5124K	£106.60	JACK & HANDLE, accessory	a/r
----	----------	---------	--------------------------	-----

Tool Roll

Our tool roll is a superb reproduction of the original. Constructed of heavy duty (original) type Tan canvas, it will keep your tools together.

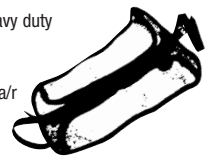

NI	385-910	£49.50	TOOL ROLL, accessory	a/r
----	---------	--------	----------------------	-----

Tyre Levers

High quality tyre levers virtually identical to those supplied with the new vehicle tool kit.

NI	AJJ281K	NCA	TYRE LEVERS, accessory	1
----	---------	-----	------------------------	---



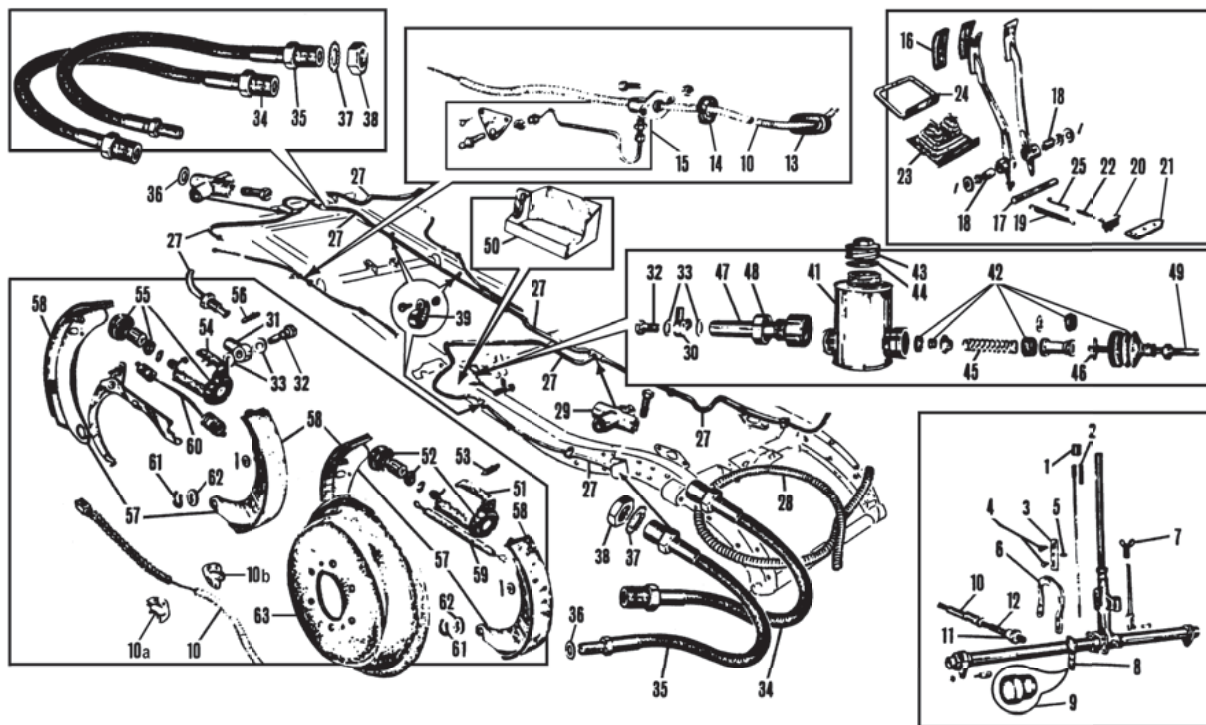

iii. Part Number Price £ea. Description Req. Details

Brake System, TA-TB & TC

Note: See the Restoration Tools catalogue for our full range of brake fluids.

Handbrake, Pipes & Hoses

Part Number	Price £ea.	Description	Req.	Details
1	181-910	NCA KNOB, handbrake lever, chrome	1	
2		NCA SPRING, handbrake knob	1	
3	181-420	NCA PAWL, handbrake	1	
4	181-415	£9.67 BOLT, stepped	2	
5		NCA STUD for pawl	1	
6	181-430	NCA RATCHET, handbrake	1	
7	181-435	NCA WING NUT, handbrake adjusting	1	
8		NCA STOP, handbrake lever	1	
9	280-285	£1.34 RUBBER BUFFER, stop	1	
10	331-050	£82.24 CABLE, handbrake, complete	2	
10a	180-155	£9.00 CLAMP, handbrake cable, (inner)	2	
10b	180-165	£12.05 CLAMP, handbrake cable, (outer)	2	
11	311-520	£5.60 NUT, cable adjusting	2	
12	ACH8508	£1.10 SPRING, cable adjusting nut	2	
13	280-670	£2.70 GROMMET, oval	2	cable to chassis
14	GHF802	£0.92 GROMMET, round	2	
15	181-920	NCA LUBRICATOR	2	handbrake cable
16	280-440	£2.62 PAD, brake & clutch	2	
17	190-480	£18.10 PEDAL SHAFT, brake & clutch	1	
18	330-050	£7.45 BUSH, brake & clutch pedal	2	
19	181-930	NCA SPRING, brake pedal	1	
20	141-600	£33.60 SWITCH, brake light	1	
21	181-945	NCA MOUNTING BRACKET	1	brake light switch
22	150-700	£5.40 SPRING, brake light switch	1	
23	280-420	£13.60 FUME EXCLUDER, rubber	1	brake & clutch pedal
24	406-700	£7.70 RETAINING PLATE, pedal excluder	1	
25	181-940	NCA WIRE CLIP, brake spring	1	
27	183-148	£156.30 BRAKE PIPE SET, (with protection coil)	1	TA & TB
	183-138	£142.00 BRAKE PIPE SET, (with protection coil)	1	TC
28	182-730	£54.00 BRAKE PIPE PROTECTION COIL	1	stainless steel
29	180-070	NCA UNION, 3 way, front & rear	2	
30	180-060	NCA BANJO, rear master cylinder	1	TC
31	3H544	£16.00 BANJO, brake pipe to rear cylinder	2	
32	11K8276	£5.70 BANJO BOLT	3	
33	324-998	£2.35 WASHER SET, banjo fittings	3	(2 washers)
34	180-530	£23.00 BRAKE HOSE, front & rear	3	TA & TB
35	180-860	£15.50 BRAKE HOSE, front & rear	3	
36	3H550	£0.46 WASHER, brake hose, copper	3	
37	WE600101	£0.34 LOCK WASHER, brake hose	3	TC
38	2K8686	£1.00 NUT, brake hose	3	
39	CP105081	£0.88 CHASSIS CLIP, brake pipe	a/r	

iii. Part Number Price £ea. Description Req. Details

Brake Shoes & Cylinders

Part Number	Price £ea.	Description	Req.	Details
180-005	£180.00	MASTER CYLINDER, complete**	1	TA & TB
180-608	£200.00	MASTER CYLINDER, complete**	1	TC
**Note: Complete master cylinders include item numbers 41 to 46.				
41	180-601	£151.00 MASTER CYLINDER	1	less rear extension & valve
42	180-900	£10.13 REPAIR KIT, master cylinder	1	
43	180-310	NCA FILLER CAP, master cylinder	1	
	500201	£5.10 FILLER CAP, master cylinder	1	alternative
44	180-660	NCA GASKET, filler cap	1	
45	180-120	NCA SPRING, piston	1	
46	326-080	£3.82 CIRCLIP, master cylinder	1	
47	180-015	£34.30 REAR EXTENSION, master cylinder	1	TA & TB
	181-950	£31.30 REAR EXTENSION, master cylinder	1	TC
48	311-365	£2.40 NUT, rear extension	1	
49	181-400	£38.50 PUSH ROD, master cylinder	1	with ball joint
50	181-960	£91.55 HEAT SHIELD, master cylinder	1	
51	180-540	£136.00 WHEEL CYLINDER, front	2	TA & TB
	180-590	£67.50 WHEEL CYLINDER, front	2	TC
52	180-930	£9.56 REPAIR KIT, front cylinder	2	
53	606733A	£1.85 BLEED SCREW, front cylinder	2	
	180-865	£7.80 SPRING & EXPANDER*	2	front
54	180-580	£70.60 WHEEL CYLINDER, rear	2	
55	180-920	£6.20 REPAIR KIT, rear cylinder	2	
56	180-110	£4.93 BLEED SCREW, rear cylinder	2	
	180-855	£10.44 SPRING & EXPANDER*	2	rear
57	182-110	£72.90 BRAKE SHOE SET	2	
58	182-240	£41.00 LINING SET, brake shoe	2	4 linings for 2 wheels
59	181-410	£5.60 SPRING, front brake shoes	2	
60	181-390	£5.80 SPRING, rear brake shoes	2	
61	326-130	£2.15 CLIP, brake shoe anchor	4	original
	326-131	NCA CLIP, brake shoe anchor	4	replacement
62	180-025	£7.10 PIVOT SPRING, front & rear brake shoes	4	
63	456-910	£315.30 ALFIN BRAKE DRUM, 9" x 1 3/4"	4	MGTA/TC

*Note: These assemblies replace the separate internal spring & star shaped internal expanders used on front and rear TA-TB-TC wheel cylinders.

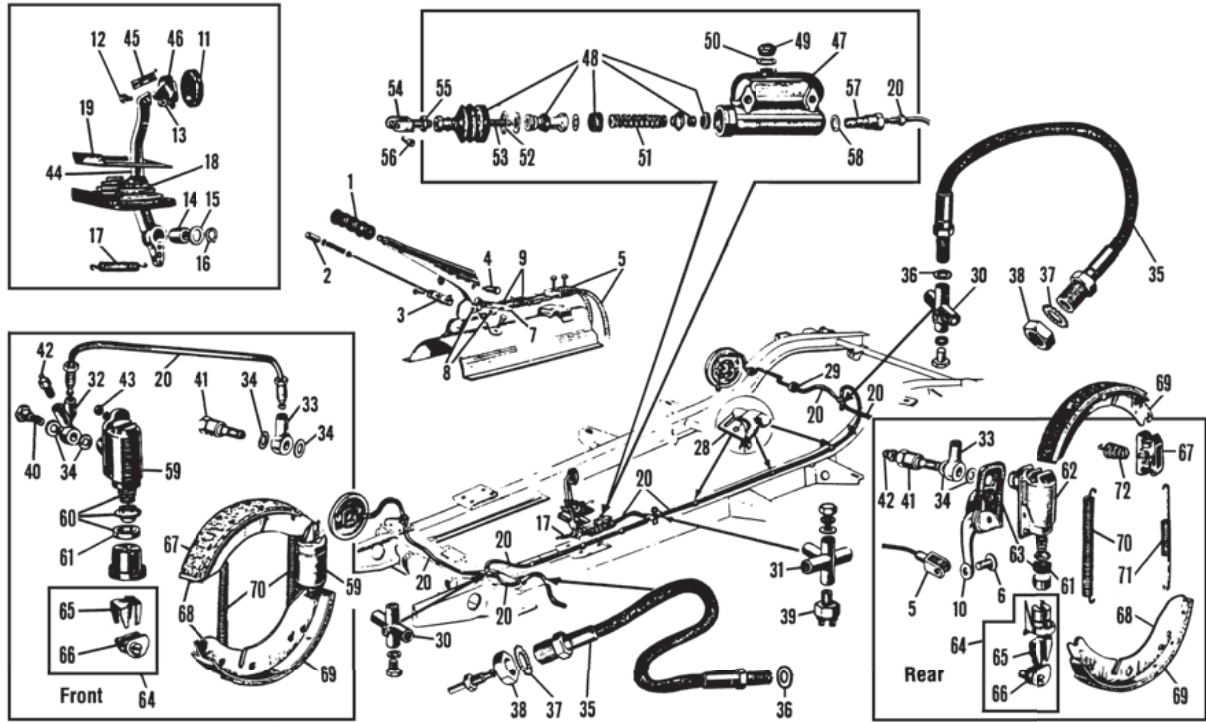

iii. Part Number Price £ea. Description Req. Details

Brake System, TD & TF

Note: See the Restoration Tools catalogue for our full range of brake fluids.

Handbrake, Pipes & Hoses

Part Number	Price £ea.	Description	Req.	Details
1	181-360	£5.24 HANDLE, handbrake lever	1	
2	ACC8956	£12.17 BUTTON, brake release, chrome	1	
3	181-320	£87.50 PAWL, handbrake ratchet	1	
4	181-440	£6.90 RIVET & WASHER	1	
5	331-060	NCA CABLE, handbrake, OE type	2	
	331-058	£21.90 CABLE, handbrake, aftermarket	2	
Note: The 331-058 handbrake cable is very similar to cables originally fitted to the MG TD and TF. All critical dimensions are correct. The OE type metal spiral housing has the unique combination of wide & narrow strips formed into a tube or housing for the inner cable. This OE type spiral housing is covered in a black plastic sheath, a non-OE feature that protects the steel housing from water, dirt, and road grime, which in turn protects the inner cable and maximizes the useful life of the e-brake system. If originality is your goal, nick the plastic cover with a knife point or a utility knife and peel the black plastic sleeve off the cable.				
6	CLZ515	£1.03 PIN, cable to rear cylinder	2	
7	181-310	£10.80 BAR, cable equalising	1	
8	311-520	£5.60 NUT, handbrake adjusting	2	
9	ACH8508	£1.10 SPRING, handbrake adjusting nut	2	
10	27H7395	NCA LEVER, handbrake	2	(inc. with rear wheel cyl.)
11	ACA5359	£1.80 PAD, brake & clutch	2	
12	320-370	£1.33 BOLT, brake & clutch pedal	2	
13	AJD8105Z	£0.18 NUT, pedal bolt	2	
14	330-100	£6.30 BUSH, brake pedal & clutch pedal	2	
15	324-430	£7.60 WASHER, pedal spacing	2	
16	326-050	£0.58 CIRCLIP, pedal shaft	1	
17	329-320	£4.74 SPRING, brake pedal	1	
18	280-420	£13.60 FUME EXCLUDER, rubber	1	brake & clutch pedal
19	406-700	£7.70 RETAINING PLATE, pedal excluder	1	
20	183-158	£73.00 BRAKE PIPE SET	1	RHD
	183-168	£73.00 BRAKE PIPE SET	1	LHD
28	326-326	£4.05 CHASSIS CLIP, brake pipe	a/r	original type
29	ACH8650	£1.90 STRAP, brake and fuel pipes	6	
30	27H7165	£26.40 UNION, 3 way	2	front & rear
31	AAA424	£37.80 UNION, 4 way	1	
32	180-681	NCA BANJO, left	1	front wheel cylinder
	180-691	NCA BANJO, right	1	
33	27H7189	£18.95 BANJO	4	front & rear wheel cylinder
34	324-908	£5.18 WASHER SET, banjo fittings	1	(12 copper washers)
35	180-840	£13.95 BRAKE HOSE, front & rear	3	
36	324-898	£3.72 WASHER SET, brake hose	1	(3 copper washers)
37	WE600101	£0.34 LOCK WASHER, brake hose	3	
38	2K8686	£1.00 NUT, brake hose	3	
39	13H2303	£7.20 SWITCH, brake light, (OE type screw)	1	on 4 way fitting

iii. Part Number Price £ea. Description Req. Details

39a	C16062A	£4.00 SWITCH, brake light, (alternative Lucar)	1	on 4 way fitting
40	7H7847	£4.37 BANJO BOLT, front wheel cylinder	2	
41	27H7167	£13.55 ADAPTOR, front & rear wheel cylinder	4	
42	27H7166	£2.00 BLEED SCREW, front & rear	4	
43	AJD8105Z	£0.18 NUT	8	
44		NCA BRAKE PEDAL, LHD	1	
	406-710	£120.00 BRAKE PEDAL, RHD*	1	
45	406-760	NCA PAD EXTENSION	1	
46	406-750	£26.40 PEDAL PAD, alloy	1	

*Note: Please see page 25 for details on LHD to RHD steering conversion parts.

Brake Shoes & Cylinders

47	LK88187	£125.00 MASTER CYLINDER	1	
48	180-910	£14.85 REPAIR KIT, master cylinder	1	
49	180-250	£26.40 FILLER CAP, master cylinder	1	
50	180-220	£2.05 WASHER, filler cap	1	
51	180-120	NCA SPRING, master cylinder piston	1	
52	326-090	£2.87 CIRCLIP, piston stop	1	
53	180-320	£10.13 PLUNGER, master cylinder	1	less clevis
54	180-485	£25.00 FORK, master cylinder plunger	1	
55	AJD8206Z	£0.41 NUT, master cylinder plunger	1	
56	325-160	£1.80 PIN, master cylinder fork	1	
57	180-710	£11.92 ADAPTOR, master cylinder	1	
58	233220A	£0.55 WASHER, master cylinder adaptor	1	
59	LK30284	£31.20 WHEEL CYLINDER, front	4	
60	180-448	£22.40 REPAIR KIT, front axle set	1	
61	7H7923	£2.10 CUP ONLY	4	
62	GWC1111	£28.80 WHEEL CYLINDER, rear	2	(does not include boot)
63	8G8243	£5.80 REPAIR KIT, rear cylinder	2	(boot & cup only)
	7H7943	£5.18 BOOT, handbrake lever	2	
64	7H7931K	£21.20 ADJUSTER KIT	4	
65	7H7930	£6.30 MASK, adjuster	4	
66	7H7931	£15.60 CAM, adjuster	4	
67	7H7932	NCA BUTMENT, rear brake shoe	2	
68	182-130	£62.70 BRAKE SHOE SET, axle set	2	
Note: This is an axle set of 4 shoes, they are the same for both front and back, so you need to order 2 sets.				
69	182-270	£41.00 LINING SET	2	4 linings for 2 wheels
70	181-370	£10.44 SPRING, brake shoe return	6	front & rear
71	181-380	£8.00 SPRING, brake shoe return	2	rear
72	AAA4714	£1.60 SPRING, brake shoe steady	4	rear, (except early TD)
NI		NCA BRAKE DRUM, front, steel wheels		for full details please refer to 'Front Suspension'
NI	264-320	£55.90 BRAKE DRUM, front, wire wheels		
NI	266-510	NCA BRAKE DRUM, rear, steel wheels		for full details please refer to 'Rear Axle'
NI	264-320	£55.90 BRAKE DRUM, rear, wire wheels		

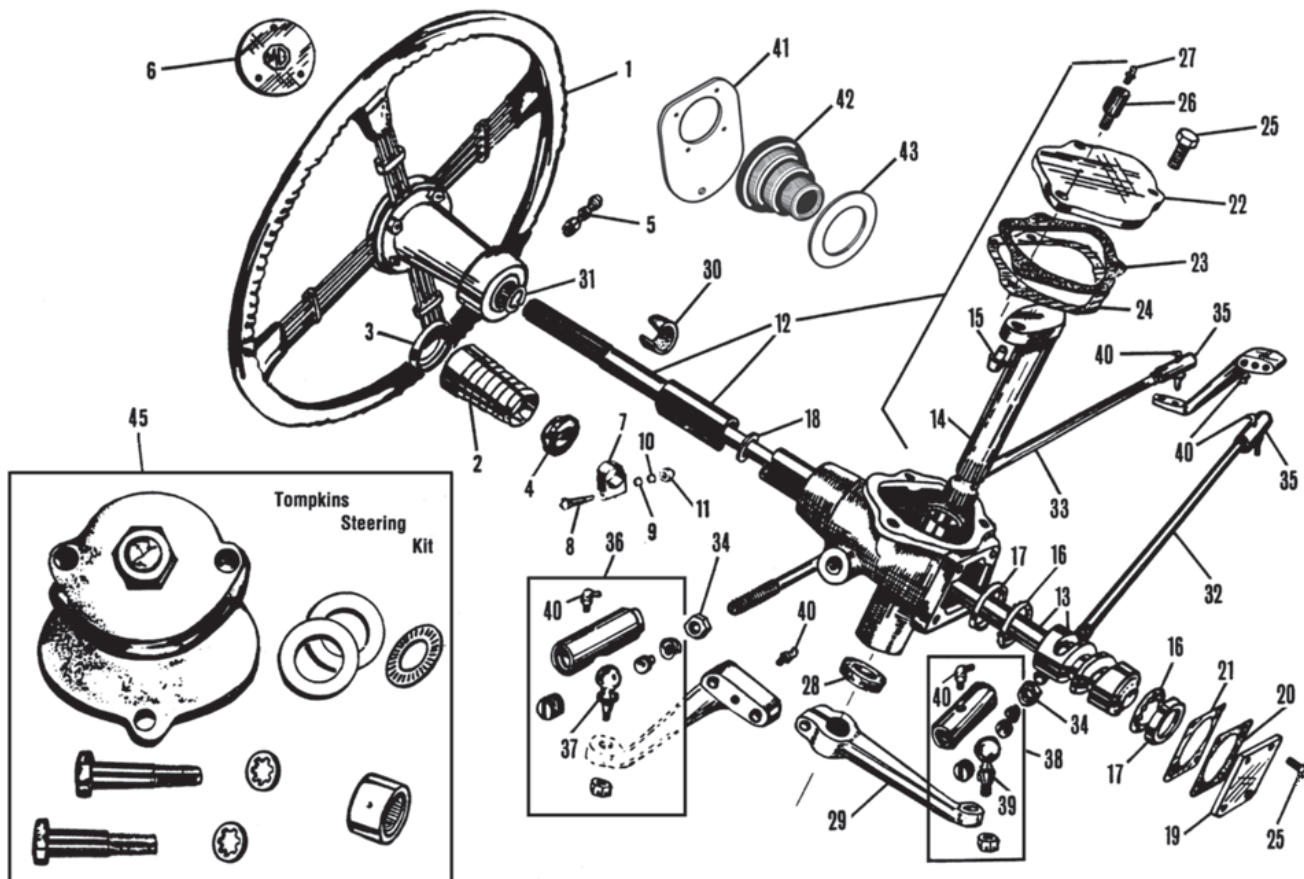

iii. Part Number Price £ea. Description Req. Details

Steering, TA-TB & TC

Note: See the Accessories section for further details of steering wheels.

These 'Brooklands' vintage steering wheels - complete with crested centrepiece and clamp bolt assembly, were available as optional equipment when the TC was new. The classic design was in demand by MG enthusiasts going well back to the 1930's.

1	454-225	£394.80	STEERING WHEEL, Brooklands, black, 17" (Key-way fitting).	1	TA to (c) 2881
	454-240	£343.80	STEERING WHEEL, Brooklands, black, 17" (Spline fitting).	1	
2	1D6163	£23.50	SPRING COVER, upper shaft, stainless	1	spline fitting only
3	108611	£7.40	CAP, spring cover, chromed	1	
4	262-290	£20.30	WASHER	1	
5	262-300	£17.12	CLAMP BOLT, steering wheel	1	
6	262-310	£24.00	CENTRE PIECE, steering wheel	1	
7	AHH6005	£10.70	CLAMP ASSEMBLY	1	
8	BH605181	£0.80	BOLT	2	
9	PWZ205	£0.19	WASHER, plain	4	
10	GHF332	£0.19	WASHER	4	
11	GHF201	£0.08	NUT	2	
12	453-120	NCA	STEERING BOX, reconditioned*	1	

*Note: We can only recondition your old steering box, new and exchange units are no longer available.

13	453-110	NCA	COLUMN & CAM	1	spline fitting only
	453-107	£194.00	COLUMN	1	
	260-085	NCA	CAM, worm only	1	
14	260-070	£174.00	SECTOR SHAFT	1	
15	501568	£11.77	PEG, sector shaft	1	
16	060371	£6.70	BEARING	2	
17	060373	£17.50	BEARING CUP	2	
18	060586	£0.19	RING, anti-rattle, rubber	1	
19	260-090	NCA	END PLATE	1	
20	060370	£0.60	GASKET, end plate	1	
21	060367	£1.03	SHIM, end plate, 0.003"	a/r	
	060368	£1.44	SHIM, end plate, 0.005"	a/r	
	060369	£1.44	SHIM, end plate, 0.010"	a/r	
22	260-100	NCA	TOP PLATE	1	
23	293-200	£6.60	GASKET, top plate	1	
24	260-010	£4.78	SHIM, top plate, 0.003"	a/r	

iii. Part Number Price £ea. Description Req. Details

260-020	£3.44	SHIM, top plate, 0.005"	a/r
260-030	£2.75	SHIM, top plate, 0.010"	a/r
320-360	£0.80	BOLT, cover plates	6
262-330	£30.65	HOLLOW BOLT, top cover plate	1
328-520	£1.03	GREASE NIPPLE, for gear oil	1
120-020	£7.45	SEAL, modern type	1
453-130	£180.00	DROP ARM	1
260-180	£3.82	FELT BUSH, upper column, original	1
326-060	£0.50	CIRCLIP, upper column	1
451-230	£66.40	DRAG LINK TUBE	1
453-290	£60.10	TIE ROD TUBE	1
311-400	£7.00	LOCK NUT	2
311-410	£7.00	LOCK NUT	2
261-238	£72.00	TIE ROD END, LH	2
261-248	£72.00	TIE ROD END, RH	1
261-260	£22.90	BALL, tie rod end	3
261-258	£100.13	DRAG LINK END ASSEMBLY, RH	1
261-270	£25.50	BALL, drag link end	1
UHN405	£2.00	GREASE NIPPLE	4
260-075	£62.00	INNER PLATE, column excluder	1
280-380	£9.00	EXCLUDER, steering column	1
260-065	£19.35	OUTER PLATE, column excluder	1

Tompkins Steering Kit

The Tompkins steering kit consists of a machined & polished aluminium casting which houses a roller thrust bearing and spacer. This replaces the steel thrust plate on top of the steering gear, thereby eliminating all drag at this critical point and, at the same time provides an easy and extremely accurate adjustment of the sector shaft.

Also included (as well as concise installation instructions) is a needle bearing which replaces the felt bush at the top of the column. While we have supplied hundreds of these kits to (very) satisfied customers, we must emphasise that unless the entire steering and front end are in perfect condition the kit will effect only a slight improvement.

With a properly set up front end, and the addition of the Tompkins steering kit, your TA-TB or TC will be a very pleasant car to drive.

45	260-118	£180.00	TOMPKINS STEERING KIT	1
----	---------	---------	-----------------------	---

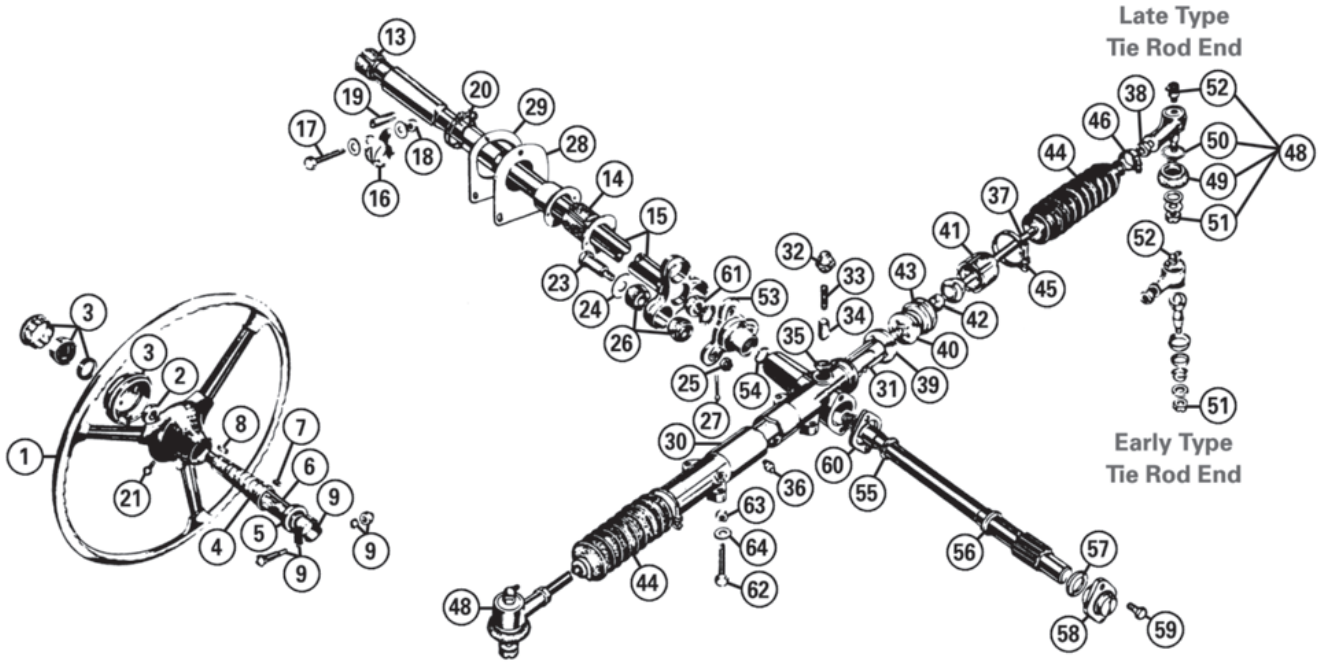

iii. Part Number Price £ea. Description Req. Details

Steering, TD & TF

Note: See the Accessories section for further details of steering wheels.

Steering Column

We are pleased to offer the first and only true original type steering wheel available since the last TF rolled off the assembly line in 1955! 'Goldish-Tan Pearlescent' trim with metallic bronze hub. (Don't be mis-led by the mottled brown rim most people consider original) The centrepiece matches the factory colour and fit.

1	454-231	£227.00	STEERING WHEEL, original type, 16.5"	1	
2	311-470	£6.50	NUT, steering wheel	1	
3	262-340	£54.70	CENTRE PIECE	1	
4	AAA1651	£10.20	SPRING COVER, upper shaft, chrome	1	
5	AAA1650	£3.22	CAP, spring cover, chrome	1	
6	262-350	NCA	ADJUSTING SHAFT	1	
7	AAA193	£5.40	KEY, steering shaft	1	
8	327-090	£5.75	KEY, steering wheel	1	
9	AAA192	£7.36	CLAMP, column, chrome	1	with nut, bolt & washer
13	260-150	£6.50	FELT BUSH, upper column	1	
14	260-200	£8.76	FELT BUSH, lower column	1	
15		NCA	INNER COLUMN	1	
16	AHH6005	£10.70	CLAMP, column	1	
17	320-390	£1.94	BOLT, 5/16" x 1.5" UNF	1	
18	AJD8105Z	£0.18	NUT	1	
19	AHH6006	£5.34	DISTANCE PIECE, clamp	1	
20	CS4020	£1.50	CLAMP, column excluder	1	
21	AJD2246	£0.46	SCREW, centre piece assembly	1	
23	320-850	£7.27	BOLT, column to flange	3	
24	324-560	£0.24	WASHER, flange bolt	3	
25	311-155	£1.39	NUT, flange bolt	3	original
	311-150	£1.99	NUT, flange bolt	3	replacement
26	280-550	£2.75	RUBBER BEARING	6	
27	GHF500	£0.12	SPLIT PIN, for slotted nut	3	
28	454-040	£38.80	EXCLUDER, steering column	1	leather
29	263-105	£32.60	PLATE, steering column excluder	1	

Rack & Pinion

30	263-134	£251.00	STEERING RACK, RHD	1	less track rod ends
	262-370	£492.00	STEERING RACK, RHD	1	bare casting only
31	262-408	NCA	RACK & PINION, RHD	1	
	262-418	NCA	RACK & PINION, LHD	1	
32	262-090	NCA	CAP, steering rack damper	1	
33	ACA5248	£5.90	SPRING, steering rack damper	1	
34	ACA5244	£10.74	DAMPER PAD, steering rack	1	

iii. Part Number Price £ea. Description Req. Details

35	ACA5249	£2.72	SHIM, steering rack damper, 0.003"	a/r	
36	328-520	£1.03	GREASE NIPPLE, steering rack	1	for gear oil
37		NCA	TIE ROD, steering	2	
38	311-360	£2.70	LOCK NUT, tie rod	2	
39	ACA5247	£4.70	LOCK WASHER, inner ball housing	2	
40	ACA6031	£33.50	BALL HOUSING, male	2	
41	ACA5304	£40.00	BALL HOUSING, female	2	
42	ACA5246	£12.00	BALL SEAT	2	
43	ACA5301	NCA	BALL SEAT SHIM, 0.003"	a/r	
	ACA5302	NCA	BALL SEAT SHIM, 0.005"	a/r	
	ACA5303	NCA	BALL SEAT SHIM, 0.010"	a/r	
44	280-560	£8.40	RACK GAITER	2	
45	ADG1682	£1.33	CLAMP, rack seal, large	2	
46	GGT1117X	£1.24	CLAMP, rack seal, small	2	
48	7H3682	£16.00	TIE ROD END	2	
49	7H3762	£2.80	BOOT, tie rod end, rubber	2	
50	7H3565	£2.29	CLIP, tie rod end boot	2	
51	311-510	NCA	NUT, for tie rod ends	2	original
	GHF224	£0.34	NUT, for tie rod ends	2	replacement
52	UHN405	£2.00	GREASE NIPPLE, tie rod end	2	
53	262-070	NCA	FLANGE, pinion shaft	1	
54	326-050	£0.58	CIRCLIP, pinion shaft	1	
55	AAA1335	£2.52	SEAL, pinion shaft	1	
56	262-080	NCA	THRUST WASHER, top pinion	1	
57	AAA1336	NCA	THRUST WASHER, bottom pinion	1	
58	262-230	NCA	TAIL BEARING, pinion	1	
59	320-360	£0.80	BOLT, tail bearing	2	
60	262-010	£4.21	TAIL BEARING SHIM, 0.005"	a/r	
	AAA1334	£1.94	TAIL BEARING SHIM, 0.007"	a/r	
61	311-360	£2.70	NUT, pinion shaft	1	
62	320-380	£1.24	BOLT, steering rack to frame	4	
63	AJD8105Z	£0.18	NUT	4	
64	GHF332	£0.19	WASHER, locking	4	

Steering Conversion Parts - LHD To RHD, TD & TF

NI	406-710	£120.00	BRAKE PEDAL, RHD	1	
NI	406-720	£120.00	CLUTCH PEDAL, RHD	1	
NI	406-770	£102.78	ACCELERATOR PEDAL, RHD	1	
NI	406-730	£125.00	PEDAL BOX, RHD	1] must be welded] through chassis
NI	406-780	£27.00	CHASSIS TUBE	1	
NI	263-134	£251.00	STEERING RACK, RHD	1	less track control arms
NI	233-570	£135.00	DASHBOARD FASCIA, plain*	1] TD only
NI	233-580	£170.70	DASHBOARD BACKING PANEL	1	

*Note: Please see page A23 for details of veneered dashboards.

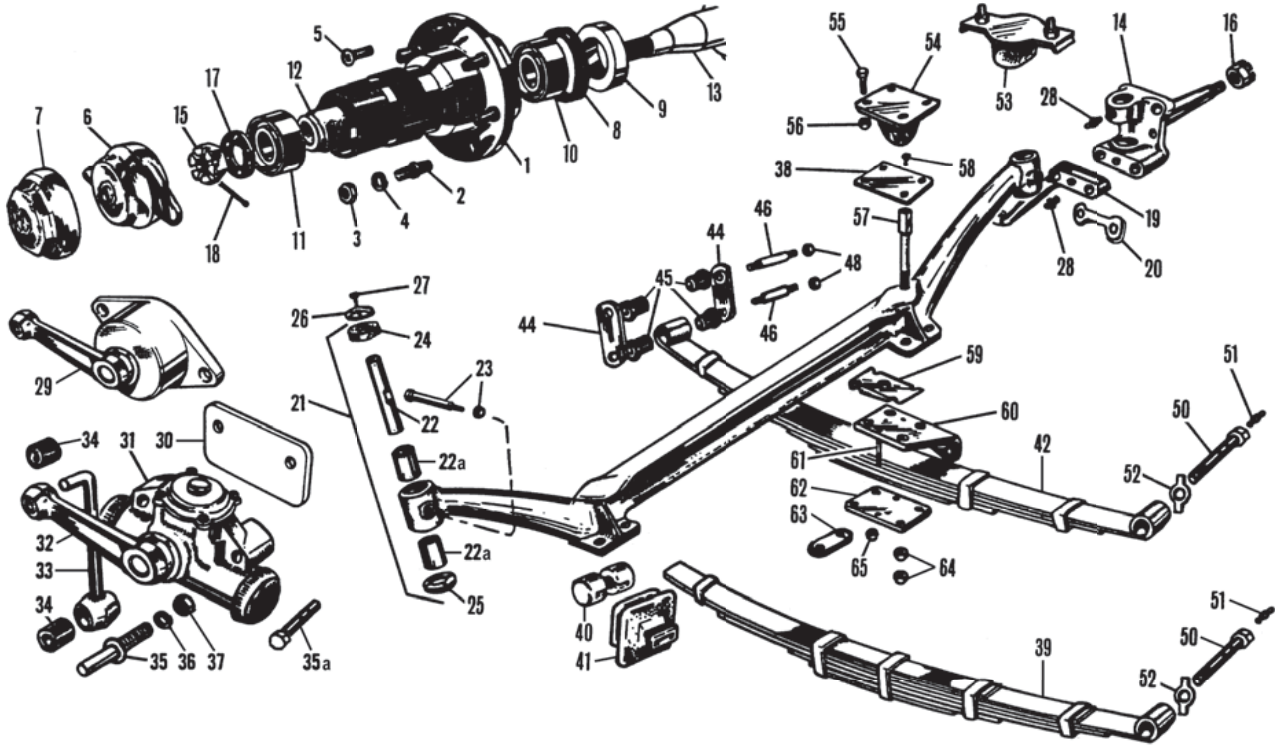

ill.	Part Number	Price £ea.	Description	Req.	Details
Front Suspension, TA-TB & TC					
1	081563	£86.45	FRONT HUB, RH	1	
	081564	£86.45	FRONT HUB, LH	1	
2	328-850	£2.60	STUD, front hub	12	
3	AJD8206Z	£3.45	NUT, hub stud	12	
4	324-340	£0.30	LOCK WASHER, hub stud	12	
5	323-748	£7.75	SCREW SET, hub to drum	1	(set of 4 screws)
6	AHH7317A	£23.80	WHEEL SPINNER, 2-eared, RH	1	with MG motif
	AHH7318A	£23.80	WHEEL SPINNER, 2-eared, LH	1	
7	AHH7315A	£24.00	WHEEL SPINNER, octagonal, RH	1	
	AHH7316A	£24.00	WHEEL SPINNER, octagonal, LH	1	
8	120-500	£2.05	OIL SEAL, front hub	2	
9	261-020	£15.60	SPACER, oil seal	2	
10	533360A	£12.85	BEARING, inner hub	2	
11	GHB176	£6.90	BEARING, outer hub	2	
12	261-010	£39.00	TUBE, bearing spacing	2	
13	261-135	NCA	STUB AXLE, RH	1	(RH thread)
14	261-145	NCA	STUB AXLE, LH	1	(LH thread)
15	311-370	£7.00	NUT, stub axle, RH	1	(RH thread)
16	311-380	£11.09	NUT, stub axle, LH	1	(LH thread)
17	324-440	£15.70	WASHER, stub axle nut	2	
18	GHF503	£0.20	SPLIT PIN	2	
19	261-140	NCA	STEERING ARM, LH	1	
	261-130	NCA	STEERING ARM, RH	1	
20	261-120	£10.50	LOCK TAB	2	
21	261-068	£133.20	KING PIN SET, (with top hat bush)	1	TA To axle no. 1500
	261-078	£143.80	KING PIN SET, (as illustrated)	1	TA From axle 1501, TB & TC
22	261-087	£36.70	KING PIN	2	
22a	330-130	£15.15	BUSH, (phosphorous bronze)	4	
23	261-097	£9.73	COTTER PIN & NUT, king pin	2	
24	261-117	£1.85	FELT WASHER, king pin	2	
25	261-107	£9.01	THRUST WASHER, king pin	2	
26	261-060	£10.60	RETAINER, felt washer	2	
27	AJD6155Z	£0.70	BOLT, felt washer retaining	2	
28	UHN405	£2.00	GREASE NIPPLE, king pin	4	
29	261-275	NCA	SHOCK ABSORBER, LUVAX, new, RH	1	TA
	261-265	NCA	SHOCK ABSORBER, LUVAX, new, LH	1	
	261-276	£158.00	SHOCK ABSORBER, LUVAX, recon, RH	1	
	261-266	£158.00	SHOCK ABSORBER, LUVAX, recon, LH	1	
(We can only recondition your old shock absorbers; new and exchange units are no longer available).					
30	261-580	£29.50	PLATE, shock mounting	2	TB & TC
31	261-500	£171.00	SHOCK ABSORBER, recon, RH	1	
	261-505	£171.00	SHOCK ABSORBER, recon, LH	1	
(We can only recondition your old shock absorbers; new and exchange units are no longer available).					
32			ARM, shock absorber	2	TB & TC

ill.	Part Number	Price £ea.	Description	Req.	Details
33	261-575	£50.70	LINK, shock absorber	4	
34	282-710	£6.10	BUSH, rubber, shock absorber link	4	
35	321-820	£27.40	STUD, shock link mounting	4	
35a	320-690	£5.05	BOLT, (7/16" x 2" BSF)	4	
36	GHF334	£0.24	LOCK WASHER, shock link stud	4	
37	311-280	£0.71	NUT, shock link stud	2	
38	261-230	£22.95	PLATE, buffer pad	2	
39	454-430	£100.13	LEAF SPRING, front	2	TA & TB
40	261-200	£34.70	TRUNNION, front spring, (pair)	2	
41	261-205	£18.95	TRUNNION BOOT	2	TC
42	AAA843X	£85.00	LEAF SPRING, front	2	
44	261-210	£46.20	SHACKLE PLATE, rear of spring	4	TC
45	ACA5242	£0.55	BUSH, spring, (standard)**	8	
	280-625	£9.50	BUSH, spring, (uprated/polyurethane)	8	
46	261-170	£8.50	SHACKLE PIN	4	
48	311-280	£0.71	NUT, shackle pin	8	
**Note: Lower bushes should be trimmed 5/8" shorter, prior to installation.					
50	261-150	£17.10	PIN, front spring	2	
51	328-520	£1.03	GREASE NIPPLE, spring pin	2	
52	261-320	£6.00	TAB WASHER, spring pin	2	
53	261-215	£58.50	BUMP STOP, on chassis	2	TA & TB
54	261-220	£15.40	BUMP STOP, on chassis	2	TC
55	320-560	£1.90	BOLT, buffer pad to chassis	4/8	TA & TB
56	AJD8106Z	£0.29	NUT, buffer pad bolt	4/8	(TB, uses 4)
57	261-160	£16.15	BOLT, axle beam	8	
58	323-738	£10.60	SCREW SET, plate to bolt	1	(set includes 8 screws)
59	261-190	£25.10	CASTOR SHIM, (can fit TB & early TC)	2	TC From (c)4251 (Fit with the wide end to the rear).
60	261-540	£74.00	BRACKET, shock mounting, LH	1	
	261-550	£74.00	BRACKET, shock mounting, RH	1	
61	261-545	£9.20	STUD	4	
62	261-555	£22.00	PLATE, spring mounting	2	
63	261-560	£9.05	PLATE, reinforcing	4	
64	AJD8105Z	£0.18	NUT, centre spring bolt	16	
65	AJD8104	£0.34	NUT, locating stud	4	

Shock Absorber Bush Installation Kit

Installing new Girling shock absorber bushes and link pins has been a great source of frustration for early TD owners for years. Replacement bushes available over the years have been either very easy to fit (and coming apart just as easily) or nearly impossible to fit! We have introduced a well designed installation tool set, with detailed instructions.



NI	MM385-890	£66.40	BUSH INSTALLATION KIT	a/r
----	-----------	--------	-----------------------	-----

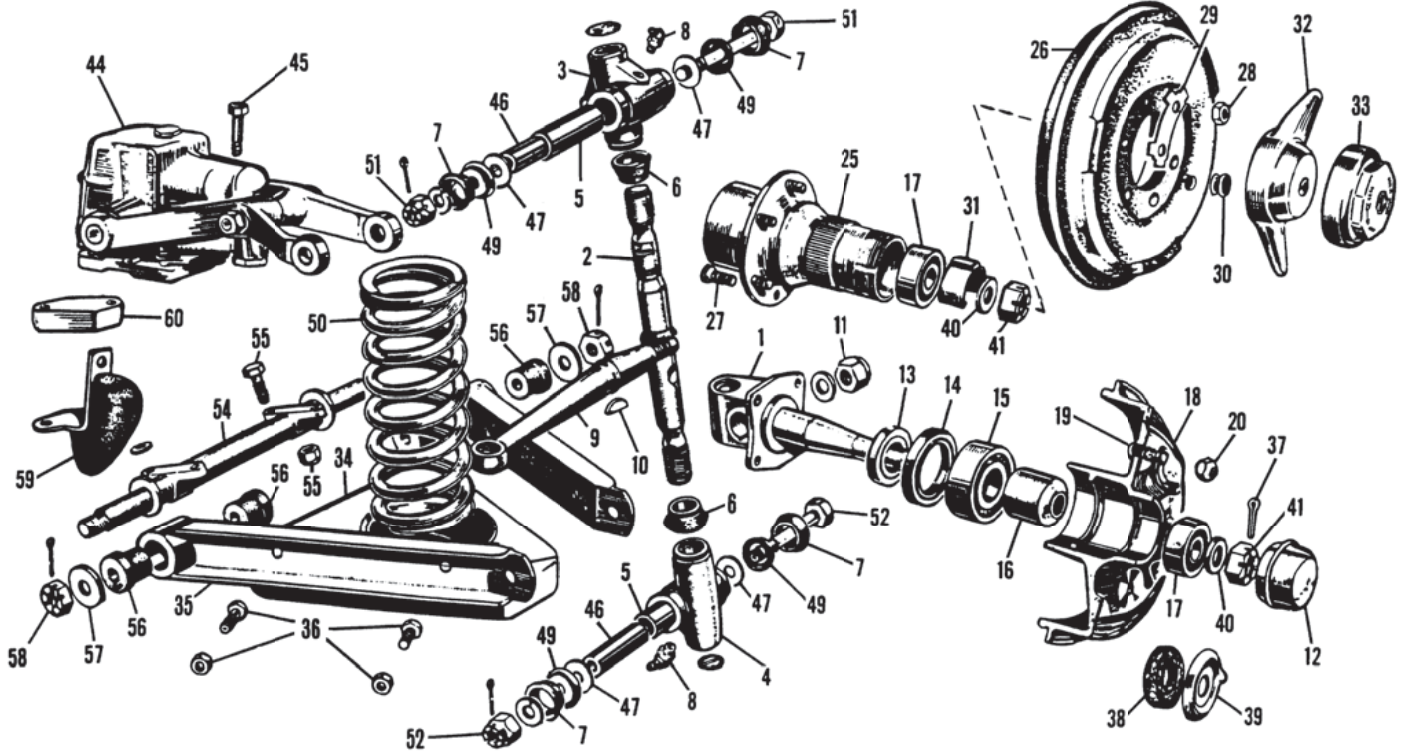

Part Number	Price £ea.	Description	Req.	Details
Front Suspension, TD & TF				
1	NCA	STUB AXLE, LH	1	
	NCA	STUB AXLE, RH	1	
2	ATB4219	£60.00 SWIVEL PIN, LH	1	
	ATB4218	£60.00 SWIVEL PIN, RH	1	
3	ATB4209	£81.20 TOP LINK, LH	1	(includes bush)
	ATB4208	£81.20 TOP LINK, RH	1	(includes bush)
4	ATB4213	£81.20 BOTTOM LINK, LH	1	(includes bush)
	ATB4212	£81.20 BOTTOM LINK, RH	1	(includes bush)
5	BTB768	£7.20 BUSH, top & bottom link	4	
6	ACG4030	£1.24 SEAL, swivel pin	4	
7	AAA1323X	£1.44 SEAL, link	8	
8	UHN405	£2.00 GREASE NIPPLE, link	4	
9	NCA	STEERING ARM, LH	1	
	NCA	STEERING ARM, RH	1	
10	WKN506	£0.76 KEY, steering arm	2	
11	311-330	£4.49 NUT, steering arm	2	
12	ATB4098	£6.20 DUST CAP	2	TD From (c) 6035 & TF
13	ACF4001	£10.40 SPACER, oil seal	2	
14	ACF4004	£3.30 OIL SEAL, front hub	2	
15	GHB177	£12.10 BEARING, inner hub	2	
16	ACF4003	£9.73 SPACER, bearing	2	
17	GHB176	£6.90 BEARING, outer hub	2	
18	NCA	BRAKE DRUM	2	steel wheels
19	264-240	£10.30 STUD, steel wheel, (BSF)	10	TD To (c) 12284
	264-110	£10.13 STUD, steel wheel, (SAE)	10	TD From (c) 12285 & TF
20	264-250	£6.60 NUT, steel wheel stud, (BSF)	10	TD To (c) 12284
	264-130	£3.76 NUT, steel wheel stud, (SAE)	10	TD from (c) 12285 & TF
25	ATB4181	£70.00 FRONT HUB, LH	1	
	ATB4180	£70.00 FRONT HUB, RH	1	
26	264-320	£55.90 BRAKE DRUM	2	
27	ATB4124	£2.10 STUD, wire wheel hub	12	wire wheels
28	NT606041	£0.44 NUT, hub stud	12	
29	ATB4125	£1.55 LOCK TAB, brake drum, (3 per drum)	6	
30	328-410	£2.87 PLUG, brake adjusting hole	2	
31	NCA	RETAINER, grease	2	
32	AHH7318A	£23.80 WHEEL SPINNER, 2-eared, LH	1	
	AHH7317A	£23.80 WHEEL SPINNER, 2-eared, RH	1	
33	AHH7316A	£24.00 WHEEL SPINNER, octagonal, LH	1	with MG crest
	AHH7315A	£24.00 WHEEL SPINNER, octagonal, RH	1	
34	AHH5925	£26.40 PAN, coil spring	2	
35	AAA1326	£6.70 WISHBONE ARM	4	
36	321-578	£6.46 BOLT & NUT SET, pan to arm	1	(includes 8 of each)
37	GHF503	£0.20 SPLIT PIN	2	
38	120-010	£7.40 HUB SEAL, felt	2	TD To (c) 6034
39	264-260	NCA GREASE RETAINER, hub	2	

Part Number	Price £ea.	Description	Req.	Details
40	324-445	£3.44 WASHER, steering knuckle nut, 5/8"	2	
	ATB4069	£4.37 WASHER, steering knuckle nut, 3/4"	2	
41	311-380	£11.09 NUT, stub axle, LH, 5/8"	1	(LH thread)
	311-370	£7.00 NUT, stub axle, RH, 5/8"	1	(RH thread)
	FNZ2412	£5.18 NUT, stub axle, LH, 3/4"	1	(LH thread)
	NL612041	£2.60 NUT, stub axle, RH, 3/4"	1	(RH thread)
44	264-355	£104.90 SHOCK ABSORBER, Armstrong*	2	reconditioned
	264-350	£106.00 SHOCK ABSORBER, Girling*	2	
*Note: Moss can only recondition your old shock absorbers, new and exchange units are no longer available. This service is available through our MGT specialist branch in Bradford.				
45	AJD6310Z	£1.44 BOLT, shock mounting	8	Armstrong shock abs.
	320-600	£1.94 BOLT, Girling damper mounting, short	4	
	320-610	£2.95 BOLT, Girling damper mounting, long	4	
46	BHH1773	£3.30 STEEL TUBE, link	4	
47	AAA1390	£0.55 THRUST WASHER	8	
49	AAA1324	£0.59 SEAL SUPPORT, link	8	cupped washer
50	139105PR	£65.80 ROAD COIL SPRING, front, (pair) (Silicon chrome).	1	
51	AHH4002K	£7.27 BOLT & NUT SET, top link	2	1 of each
52	AHH4001K	£5.20 BOLT & NUT SET, bottom link	2	1 of each
54	AHH4003	£21.00 PIVOT, wishbone arm	2	
55	321-618	£1.55 BOLT & NUT SET, wishbone arm pivot	8	1 of each
56	AHH7933	£0.56 BUSH, wishbone arm, standard	8	
	BHH1123	£1.20 BUSH, wishbone arm, one piece	4	MGB V8 type
	BHH1123SPK	£38.30 BUSH SET, wishbone arm, polyurethane	1	alternative
57	AAA1330	£0.55 WASHER, wishbone arm pivot	4	
58	NL608041	£1.10 NUT, wishbone arm pivot	4	fits replacement pivots
59	AAA5023	£8.50 REBOUND RUBBER	2	requires spacer
60	AAA5024	£3.70 SPACER, rebound rubber	2	standard on late cars
NI	386-600	£31.50 THREAD RESTORER, BSW/BSF	a/r	see also General Hardware a/r on page 62 (For restoring damaged threads on bolts/studs).
NI	386-610	NCA THREAD RESTORER, metric	a/r	

Shock Absorber Bush Installation Kit

Installing new Girling shock absorber bushes and link pins has been a great source of frustration for early TD owners for years. Replacement bushes available over the years have been either very easy to fit (and coming apart just as easily) or nearly impossible to fit! We have introduced a well designed installation tool set, with detailed instructions.



NI	MM385-890	£66.40	BUSH INSTALLATION KIT	a/r
----	-----------	--------	-----------------------	-----

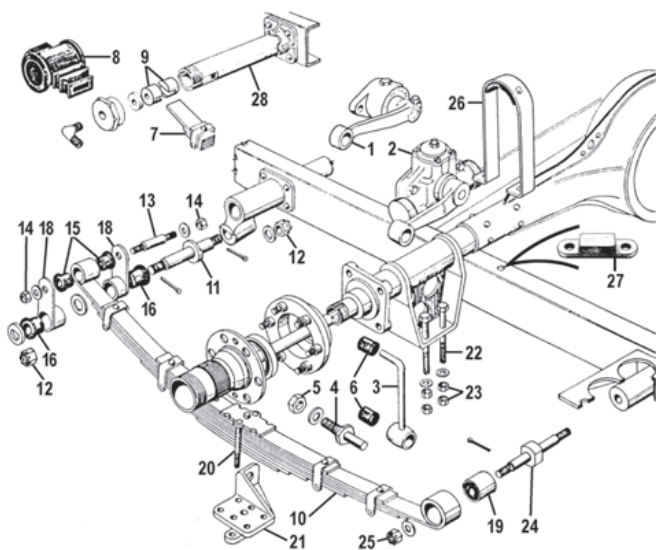

TA, TB, TC Models

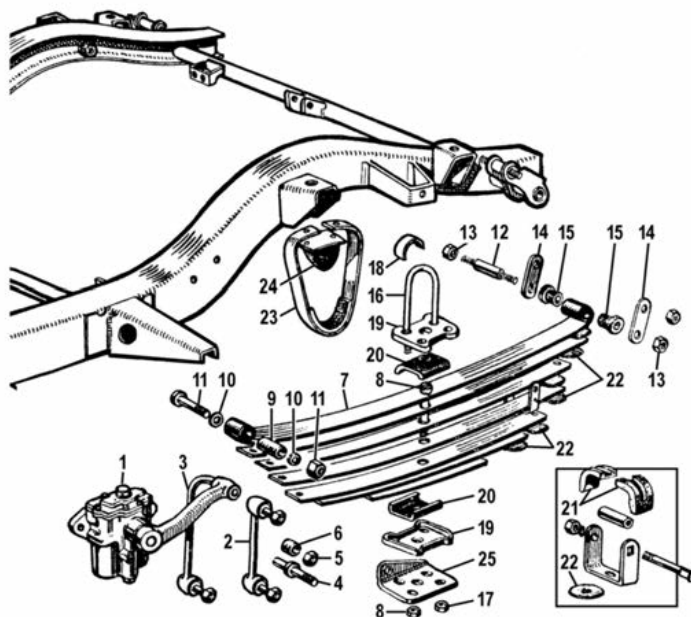

TD, TF Models

Ill.	Part Number	Price £ea.	Description	Req.	Details
Rear Suspension, TA-TB & TC					
1	261-285	NCA	SHOCK ABSORBER, LUVAX, new, LH	1	TA
	261-295	NCA	SHOCK ABSORBER, LUVAX, new, RH	1	
	261-286	£158.00	SHOCK ABSORBER, LUVAX, recon, LH	1	
	261-296	£158.00	SHOCK ABSORBER, LUVAX, recon, RH	1	
2	261-400	£169.20	SHOCK ABSORBER, recon, LH	1	TB & TC
	261-410	£169.20	SHOCK ABSORBER, recon, RH	1	

Note: Moss can only recondition your old shock absorbers; new and exchange units are no longer available. This service is available through our MGT specialist branch in Bradford.

3	261-525	£45.20	LINK, shock absorber	2	TA & TB
4	321-820	£27.40	STUD, shock link	2	
5	311-280	£0.71	NUT, shock link stud	2	
6	282-710	£6.10	BUSH, shock absorber link, rubber	4	
7	454-435	£136.70	REAR SPRING, includes 'Silent Bloc' bush*	2	
8	261-235	£19.00	TRUNNION BOOT	2	
9	261-225	£35.60	TRUNNION, rear spring, (pair)	2	

*Note: See item 28.

10	AAA846X	£150.00	REAR SPRING, inc: 'Silent Bloc' bush	2	TC	
11	261-510	£142.40	SHACKLE PIN, lower rear spring	2		
12	PW081	£5.60	NUT, lower rear pin	4		
13	261-180	£7.27	SHACKLE PIN, upper rear spring	2		
14	311-280	£0.71	NUT, upper rear pin	4		
15	ACA5242	£0.55	BUSH, upper, (standard)	4		
	280-625	£9.50	BUSH, upper, (uprated/polyurethane)	4		
16	280-620	£7.48	BUSH, lower, large, (standard)	4		
	280-615	£12.50	BUSH, poly. lower, large, (uprated)	4		alternative to 280-620
NI	323-975	NCA	FIBRE WASHER, rear shackle	2		
18	261-515	NCA	SHACKLE PLATE, rear spring	4		
19	081752	£8.34	SILENTBLOC BUSH	2		TA-TB & TC
20	261-570	£34.70	TOP PLATE, rear spring, with studs	2		
21	261-595	NCA	SHOCK BRACKET, RH	1		
	261-590	NCA	SHOCK BRACKET, LH	1		
22	320-878	£20.00	BOLT & NUT SET, axle to spring	1	car set	
23	AJD8105Z	£0.18	NUT, (2 per bolt)	16		
24	261-330	£95.00	STUD, spring mounting	2		
25	311-335	£0.72	NUT, mounting stud	2		
26	261-340	£25.00	CHECK STRAP, rear axle	2		
27	280-660	£3.67	BUFFER, rear axle	2		
28	PW072	£82.20	TRUNNION BUSH REPAIR, RH	1	TA & TB	
	PW072A	£82.20	TRUNNION BUSH REPAIR, LH (Also known as sliding bush).	1		

Rear Suspension, TD & TF

1	NBM148	£105.00	SHOCK ABS', rear, new, less link, LH	1	Armstrong
	NBM149	£105.00	SHOCK ABS', rear, new, less link, RH	1	
	261-440	£100.13	SHOCK ABS', rear, reconditioned, LH*	1	

Ill.	Part Number	Price £ea.	Description	Req.	Details
	261-450	£100.13	SHOCK ABS', rear, reconditioned, RH*	1	Girling
	261-420	£125.44	SHOCK ABS', rear, reconditioned, LH*	1	
	261-430	£125.44	SHOCK ABS', rear, reconditioned, RH*	1	

*Note: On the shocks listed above, we can only recondition your old shock absorbers, new and exchange units are no longer available. This service is available through our MGT specialist branch in Bradford.

Koni Shock Absorber Conversion - Make your T Type handle

NI	267-658	£404.50	KONI CONVERSION KIT	1	use only when Koni conversion kit fitted	
NI	MM267-657PR	£100.13	KONI SHOCK ABSORBER, pair	2		
2	266-480	£25.50	LINK	2	Armstrong	
3	266-455	£51.50	LINK	2	Girling	
4	321-820	£27.40	STUD, shock link	2		
5	311-280	£0.71	NUT, shock link stud	2		
6	282-710	£6.10	BUSH, shock link	2	TD	
7	AAA2372	£115.00	REAR SPRING, (inc. 'Silent Bloc' bush)	2		
	AAA5031	£115.00	REAR SPRING, (inc. 'Silent Bloc' bush)	2	TF	
8	321-228	£12.07	BOLT & NUT SET, centre leaf spring	2	one of each	
9	AAA629	£2.40	'SILENT BLOC' BUSH	2		
10	324-195	£1.30	WASHER, fibre	4		
11	322-718	£6.10	BOLT & NUT SET, pivot	2		
12	261-170	£8.50	SHACKLE PIN, rear spring	4		
13	311-280	£0.71	NUT, shackle pin	8		
14	266-440	£15.60	SHACKLE PLATE	4		
15	ACA5242	£0.55	BUSH, rear spring, standard	8		
	280-625	£9.50	BUSH, rear spring, uprated	8		polyurethane
16	266-420	£6.30	'U' BOLT	4		
17	AJD8336Z	£0.60	NUT, nyloc	8		
18	AHH5082	£5.60	BUFFER PLATE, 'U' bolt to housing	2		optional to prevent chafing
19	266-450	£10.25	PLATE, spring centre	4		
20	280-630	£4.21	PAD, spring seating	4		
	ACA5138SPK	£37.30	PAD SET, spring seating, polyurethane, axle set	1	alternative	
21	280-640	£2.50	PAD, spring clip	8		
22	280-650	£2.80	PAD, between leaves	24		
23	266-430	£39.00	CHECK STRAP	2		
24	266-500	£14.15	REBOUND RUBBER, rear axle	2		
25	266-620	NCA	BRACKET, shock link, LH	1		
	266-630	NCA	BRACKET, shock link, RH	1		

Shock Absorber Bush Installation Kit

Installing new Girling shock absorber bushes and link pins has been a great source of frustration for TA-TB-TC and early TD owners for years. Replacement bushes available over the years have been either very easy to install (and coming apart just as easily) or nearly impossible to install! We have introduced a well-designed installation tool set, with detailed installation instructions.



NI	MM385-890	£66.40	BUSH INSTALLATION KIT	a/r
----	-----------	--------	-----------------------	-----

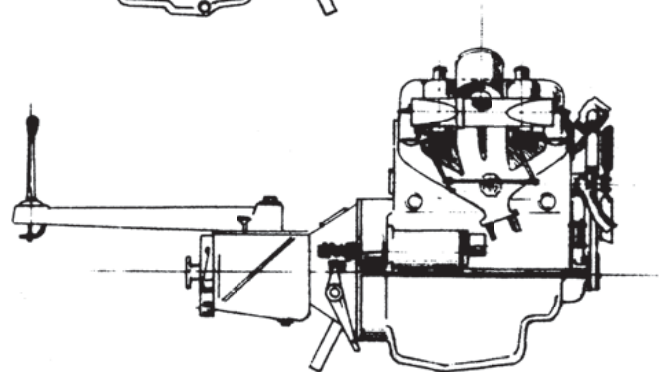
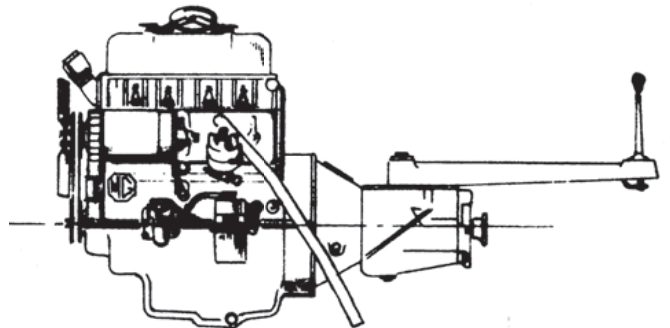
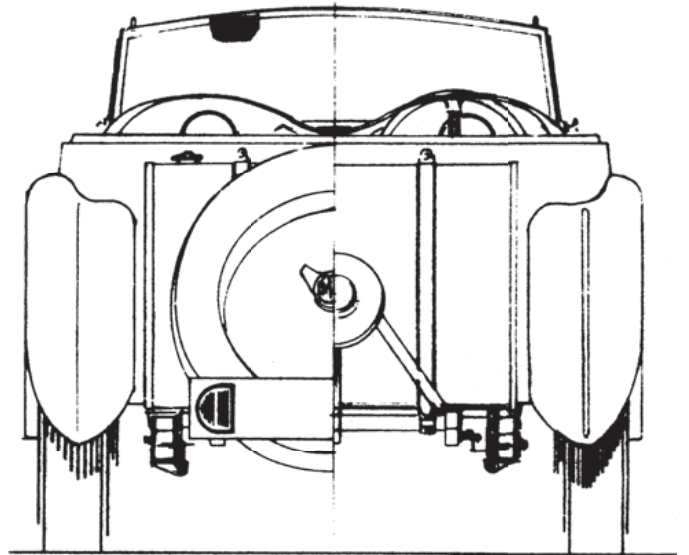
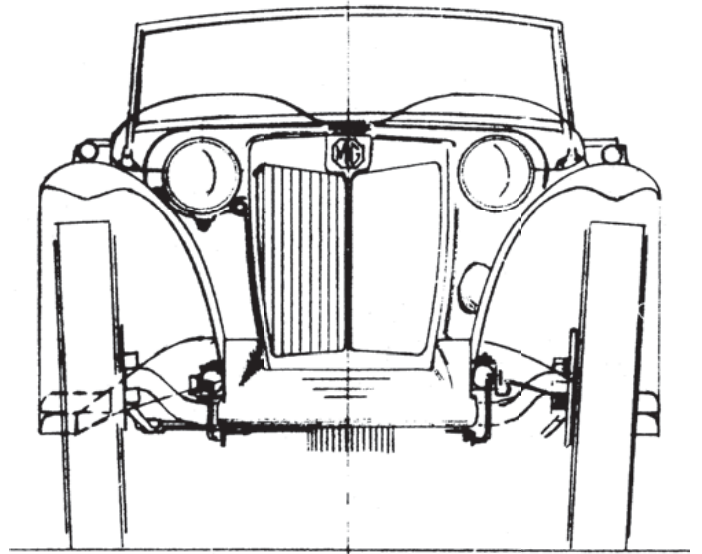
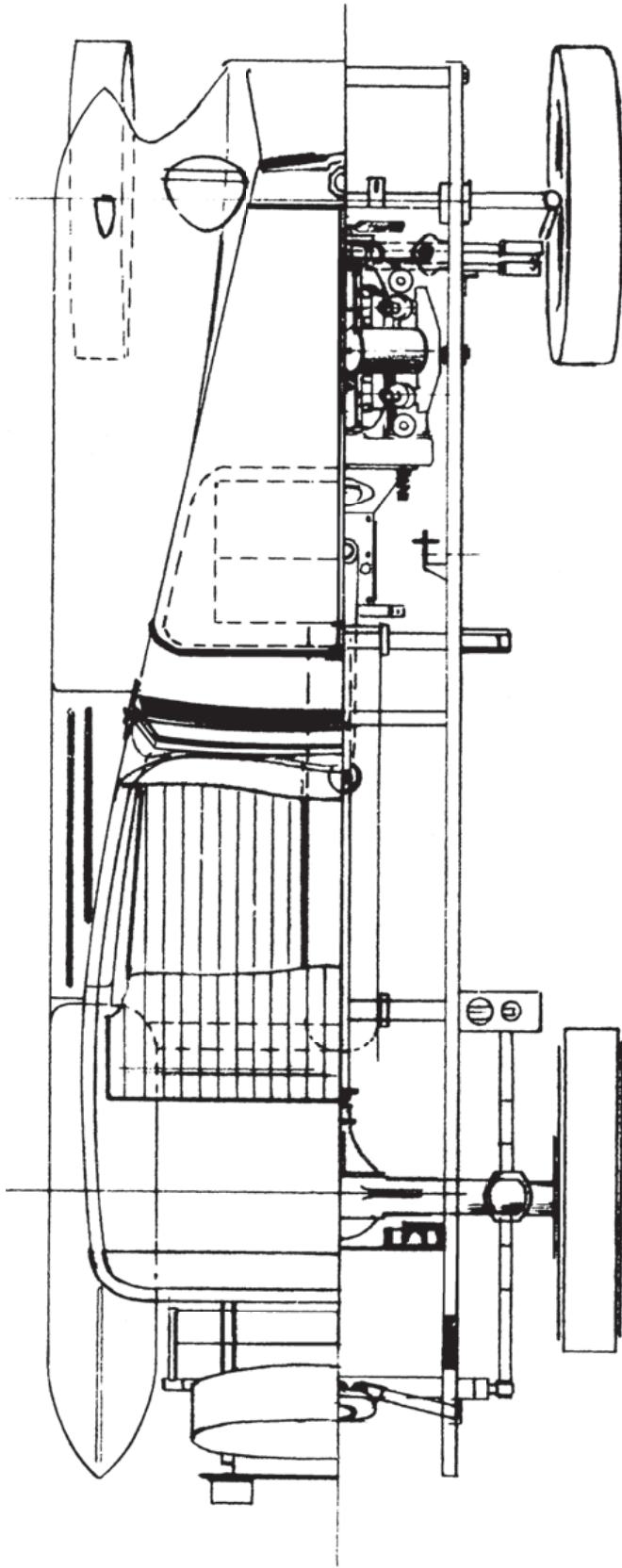

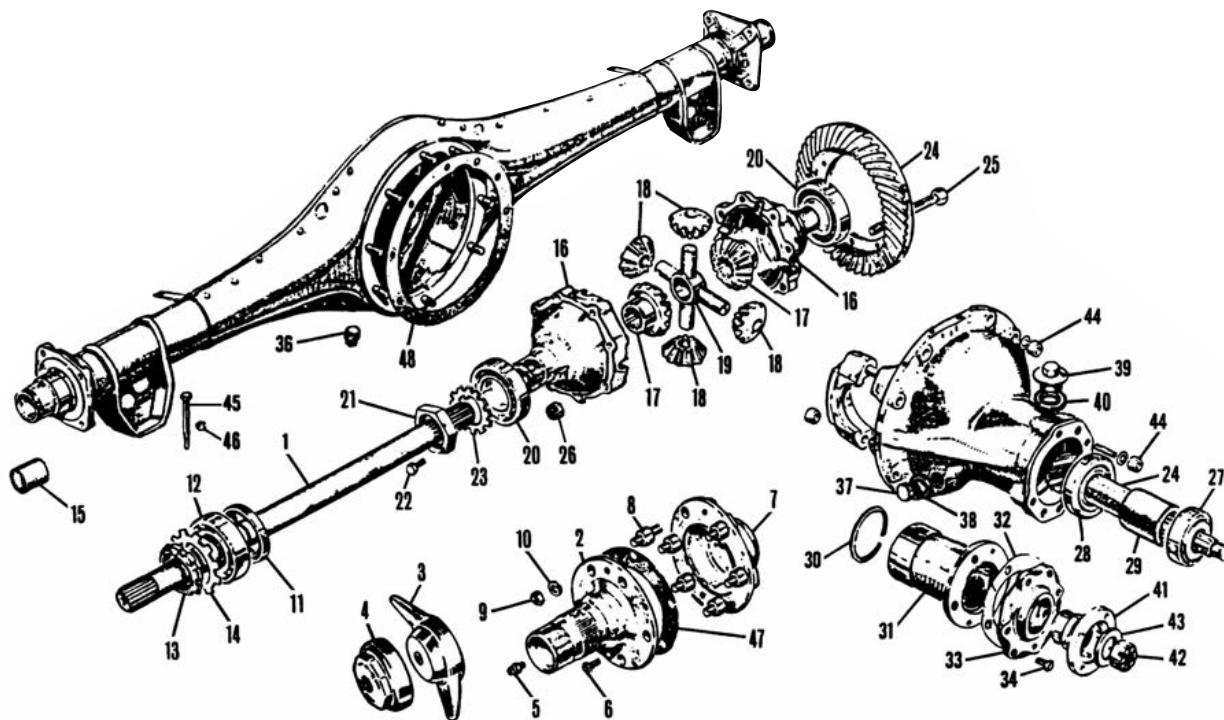

ill. Part Number Price £ea. Description Req. Details

Rear Axle, TA-TB & TC

Axle Shaft & Hubs

1	453-210	£114.89	AXLE SHAFT	2	
2	AAA539	£79.30	REAR HUB, RH	1	
	AAA540	£79.30	REAR HUB, LH	1	
3	AHH7317	£24.50	WHEEL SPINNER, 2-eared, RH	1	alternative
	AHH7317B	£24.00	WHEEL SPINNER, 2-eared, RH	1	with MG motif
	AHH7317A	£23.80	WHEEL SPINNER, 2-eared, RH	1	
	AHH7318	£24.50	WHEEL SPINNER, 2-eared, LH	1	alternative
	AHH7318B	£24.00	WHEEL SPINNER, 2-eared, LH	1	with MG motif
	AHH7318A	£23.80	WHEEL SPINNER, 2-eared, LH	1	
4	AHH7315	£24.00	WHEEL SPINNER, octagonal, RH	1	with MG motif
	AHH7315A	£24.00	WHEEL SPINNER, octagonal, RH	1	
	AHH7316	£24.00	WHEEL SPINNER, octagonal, LH	1	with MG motif
	AHH7316A	£24.00	WHEEL SPINNER, octagonal, LH	1	
5	328-520	£1.03	GREASE NIPPLE, rear hub	2	
6	323-748	£7.75	SCREW SET, rear hub	1	includes 4 screws
7	265-130	£107.35	HOUSING, bearing	2	includes studs
8	328-840	£16.80	STUD, bearing housing	12	
9	AJD8206Z	£3.45	NUT, bearing housing stud	12	
10	324-340	£0.30	WASHER, bearing housing stud	12	
11	AAA969	£4.37	OIL SEAL, rear hub	2	
12	B104	£21.30	BEARING, rear hub	2	
13	265-110	£55.00	LOCK NUT, RH	1	(RH thread)
	265-120	£55.00	LOCK NUT, LH	1	(LH thread)
14	265-100	£4.21	TAB WASHER, lock nut	2	
15	330-210	£17.50	BUSH, oil return, RH	1	important item that's
	330-110	£17.50	BUSH, oil return, LH	1	very often overlooked

Differential & Pinion Gears

16	NCA	CASE, differential	1	
17	NCA	GEAR, differential	2	
18	265-040	NCA GEAR, pinion	4	
19	265-050	NCA SPIDER, differential	1	
20	2K5943	£17.00 BEARING, differential carrier	2	
21	NCA	ADJUSTING NUT, differential bearing	2	
22	265-030	NCA SCREW, adjusting nut	2	
23	NCA	LOCK RING, adjusting nut	2	
24	265-000	£611.00 C/WHEEL & PINION, 4.875:1*	1	TA & TB
	265-010	£611.00 C/WHEEL & PINION, 5.125:1*	1	TC

*Note: Can be used as alternatives.

25	AJD6220Z	£1.80	BOLT, ring & pinion	8	
26	AJD8105Z	£0.18	NUT, for bolt	8	
27	125-020	£81.28	BEARING, front pinion, single row	1	TA
	125-000	£48.20	BEARING, front pinion, double row	1	TB & TC
28	128-100	£55.90	BEARING, rear pinion, roller bearing	1	
29	265-020	NCA	SPACER, pinion bearing	1	
30	NCA		SPRING CLIP, rear pinion bearing	1	

ill. Part Number Price £ea. Description Req. Details

31	265-190	NCA	HOUSING, pinion	1	
32	263-470	£3.30	SHIM, 0.002"	a/r	
	263-480	£3.30	SHIM, 0.005"	a/r	
	263-490	£3.30	SHIM, 0.010"	a/r	

TA-TB & TC Differential Pinion Cap

This re-engineered item incorporates a modern double-lipped oil seal in a precision machined alloy housing. The really clever aspect of this design is that the seal is positioned so as to fit against the unworn portion of the original pinion flange, eliminating any need for machine work. The installed unit, when painted, duplicates the original appearance.



33	265-198	£86.10	DIFFERENTIAL PINION CAP	1	
	120-110	£8.70	SEAL, replacement for pinion cap	a/r	
34	NCA		SCREW, housing cap	2	

Rear Axle Case Fittings

36	328-090	£15.70	PLUG, oil drain	1	
37	NCA		PLUG, oil level indicator	1	
38	NCA		WASHER, oil level plug	1	
39	NCA		PLUG, oil filler	1	
40	NCA		WASHER, oil filler plug	1	
41	265-200	NCA	FLANGE, pinion	1	
42	311-430	£14.65	NUT, pinion flange	1	
43	NCA		WASHER, pinion flange nut	1	
44	AJD8105Z	£0.18	NUT	14	
45	320-878	£20.00	BOLT & NUT SET, axle to spring	1	car set
46	AJD8105Z	£0.18	NUT	16	2 per bolt
47	294-200	£1.60	GASKET, rear hub	2	
48	294-300	£3.44	GASKET, differential	1	

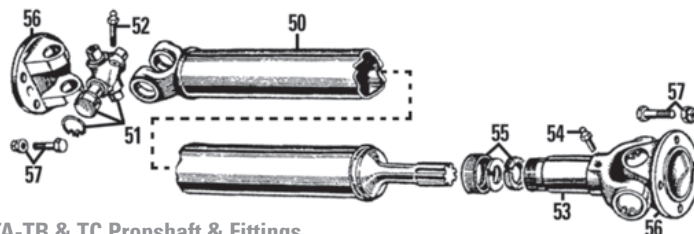

TA-TB & TC Propshaft & Fittings

50	268-015	£212.50	PROPSHAFT	1	
51	GUJ115	£9.30	UNIVERSAL JOINT, greaseable	2	
	GUJ115Z	£8.50	UNIVERSAL JOINT, greaseable	2	aftermarket
52	549229A	£1.64	GREASE NIPPLE, universal joint	2	
53	7H3865	£39.40	YOKE	1	
54	549229A	£1.64	GREASE NIPPLE, yoke	1	
55	7H3880X	£3.60	DUST CAP & CORK SEAL SET, yoke	1	
56	7H3863	£16.00	FLANGE	2	
57	321-338	£9.11	BOLT & NUT SET	2	4 bolts & nuts for 1 flange

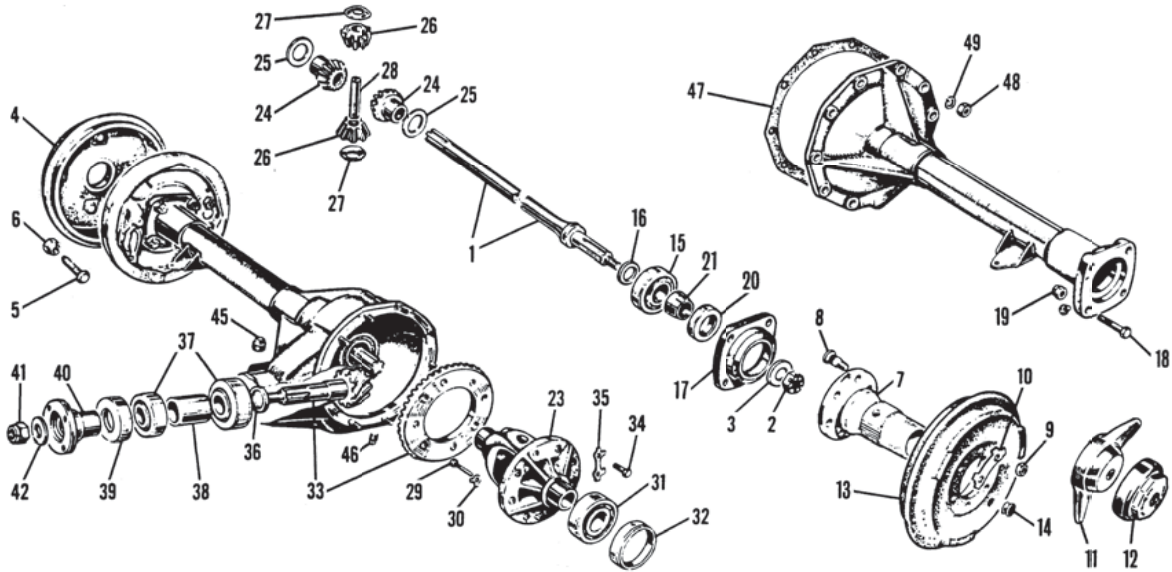

Part Number	Price £ea.	Description	Req.	Details
1	453-220	AXLE SHAFT, (SAE)	2	use part no. 310-590 ut
2	311-490	NUT, axle shaft, (BSF), (11 TPI)	2	TD To (c) 12284
	310-590	NUT, axle shaft, (SAE), (14 TPI)	2	TD From (c) 12285 & TF
3	324-500	WASHER, axle shaft nut	2	
4	266-510	NCA BRAKE DRUM	2	steel wheels
5	264-240	£10.30 STUD, steel wheel, (BSF)	10	TD To (c) 12284
	264-110	£10.13 STUD, steel wheel, (UNF)	10	TD From (c) 12285 & TF
6	264-250	£6.60 NUT, steel wheel stud, (BSF)	10	TD To (c) 12284
	264-130	£3.76 NUT, steel wheel stud, (UNF)	10	TD From (c) 12285 & TF
7	AAA1113	£80.00 REAR HUB, wire wheels, LH	1	
	AAA1112	£80.00 REAR HUB, wire wheels, RH	1	
8	ATB4124	£2.10 STUD, wire wheel hub	12	
9	NT606041	£0.44 NUT, hub stud	12	
10	ATB4125	£1.55 LOCK TAB, brake drum	6	3 per drum
11	AHH7317	£24.50 WHEEL SPINNER, 2-eared, RH	1	
	AHH7317B	£24.00 WHEEL SPINNER, 2-eared, RH	1	alternative
	AHH7317A	£23.80 WHEEL SPINNER, 2-eared, RH	1	with MG motif
	AHH7318	£24.50 WHEEL SPINNER, 2-eared, LH	1	
	AHH7318B	£24.00 WHEEL SPINNER, 2-eared, LH	1	alternative
	AHH7318A	£23.80 WHEEL SPINNER, 2-eared, LH	1	with MG motif
12	AHH7315	£24.00 WHEEL SPINNER, octagonal, RH	1	
	AHH7315A	£24.00 WHEEL SPINNER, octagonal, RH	1	with MG motif
	AHH7316	£24.00 WHEEL SPINNER, octagonal, LH	1	
	AHH7316A	£24.00 WHEEL SPINNER, octagonal, LH	1	with MG motif
13	264-320	£55.90 BRAKE DRUM	2	wire wheels
14	328-410	£2.87 PLUG, brake adjusting hole	2	
15	GHB158	£11.70 BEARING, rear hub	2	
16	266-020	£19.45 SPACER, rear hub bearing	2	
17	NCA	HOUSING, bearing	2	
18	NCA	BOLT, housing	8	
19	AJD8336Z	£0.60 NUT, nyloc, bearing housing bolt	8	
20	GHS179	£1.70 OIL SEAL, rear hub	2	
21	AAA982	£26.40 COLLAR, oil seal	2	

Differential & Pinion Gears

23	NCA	CASE, differential	1	
24	NCA	GEAR, differential	2	
25	266-370	£19.80 THRUST WASHER, differential gear	2	
26	NCA	GEAR, pinion	2	
27	266-010	NCA THRUST WASHER, pinion gear	2	
28	266-360	NCA PIN, pinion gear	1	
29	320-210	NCA BOLT, pinion gear pin	1	
30	266-350	NCA LOCK TAB, pinion pin bolt	1	
31	2K5943	£17.00 BEARING, differential	2	
32	266-180	NCA COLLAR, differential bearing, 0.496"	a/r	
	266-190	NCA COLLAR, differential bearing, 0.497"	a/r	
	266-200	NCA COLLAR, differential bearing, 0.498"	a/r	
	266-220	NCA COLLAR, differential bearing, 0.500"	a/r	
	266-230	NCA COLLAR, differential bearing, 0.501"	a/r	
	266-240	NCA COLLAR, differential bearing, 0.502"	a/r	
	266-250	NCA COLLAR, differential bearing, 0.503"	a/r	
	266-270	NCA COLLAR, differential bearing, 0.505"	a/r	
	266-280	NCA COLLAR, differential bearing, 0.506"	a/r	

TD & TF Crown Wheel & Pinion Gear Sets

Crown wheel & pinion gear sets for the TD & TF are no longer available. While original gear sets are very longwearing, standard rear axle ratios (particularly the 5.125:1 ratio as fitted to most TD's) are not well suited to modern highway driving conditions. We feel that the best ratio for a regularly driven TD or TF is a 4.55:1 ratio (fitted as standard on MG ZA & ZB models). MGA or MG ZA/ZB gear sets can be fitted without permanent modification. We offer a 'crown wheel & pinion conversion' Workshop Manual (part no. 212-350) which covers this somewhat detailed process. A complete CW&P conversion kit (102262K) consisting of all the major parts needed to convert to the MGA CW&P is available in addition to the manual. Includes crown wheel & pinion, spacer & pinion bearing. It does not include parts for a normal rebuild; you will need to buy these separately.

33	ATB7056	NCA	CROWN WHEEL & PINION, 4.875:1	1	original
	102262	£115.94	CROWN WHEEL & PINION, 4.55:1	1	alternative
34	321-198	NCA	BOLT SET, ring & pinion, (BSF)	1	TD To (c) 12284
	322-668	£5.24	BOLT SET, ring & pinion, (SAE)	1	TD From (c) 12285 & TF
35	266-040	£7.30	LOCK TAB, ring & pinion bolt	4	
36	266-070	NCA	WASHER, 0.119"	a/r	pinion adjusting
	266-090	NCA	WASHER, 0.121"	a/r	
	266-120	NCA	WASHER, 0.124"	a/r	
	266-130	NCA	WASHER, 0.125"	a/r	
	266-150	NCA	WASHER, 0.127"	a/r	
	266-160	NCA	WASHER, 0.128"	a/r	
37	129-008	£94.55	BEARING SET, pinion, 2 bearings	1	original CW&P ATB7056
	100897A	£25.00	BEARING, pinion, inner	1	alternative CW&P 102262
	2A7213	£22.00	BEARING, pinion, outer	1	
	212-350	£16.75	MANUAL, conversion CW&P	1	
	102262K	£212.00	CONVERSION KIT, CW&P, 4.55:1	1	

Note: The bearing set 129-008 can only be used with original CW&P ATB7056 which is NLA. We advise you buy CW&P conversion kit 102262K along with conversion manual 212-350.

38	266-490	NCA	SPACER, pinion bearing	1	
39	88G320	£3.00	OIL SEAL, pinion	1	
40	266-340	£71.00	FLANGE, pinion	1	
	ATB7059	£114.00	FLANGE, pinion*	1	MGA type
41	311-430	£14.65	NUT, pinion flange, (BSF)	1	TD To (c) 12284
	510618A	£2.90	NUT, pinion flange, (SAE)	1	TD From (c) 12285 & TF
42	324-470	NCA	WASHER, pinion flange nut	1	
43	328-130	£3.61	PLUG, oil filler	1	
44	328-090	£15.70	PLUG, oil drain	1	
45	294-400	£2.60	GASKET, differential housing	1	
46	AJD8105Z	£0.18	NUT, cover stud, (BSF)	10	TD To (c) 12284
47	GHF202	£0.12	NUT, cover stud, (UNF)	10	TD From (c) 12285 & TF
48	GHF302	£0.19	LOCK WASHER, cover stud nut	10	

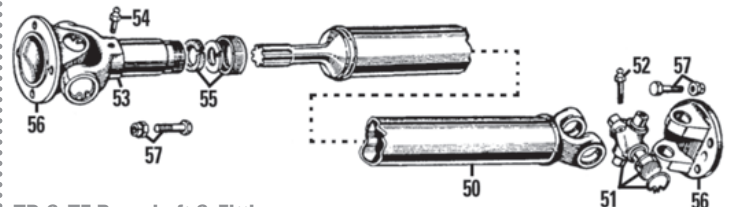

TD & TF Propshaft & Fittings

50	268-025	£153.30	PROPSHAFT	1	
51	GUJ115	£9.30	UNIVERSAL JOINT, greaseable	2	
	GUJ115Z	£8.50	UNIVERSAL JOINT, greaseable	2	aftermarket
52	7H3858	£1.85	GREASE NIPPLE, universal joint	1	
53	7H3865	£39.40	YOKE	1	
54	549229A	£1.64	GREASE NIPPLE, yoke	1	
55	7H3880X	£3.60	DUST CAP & CORK SEAL SET, yoke	1	
56	7H3863	£16.00	FLANGE	2	
57	321-338	£9.11	BOLT & NUT SET	2	4 bolts & nuts for 1 flange

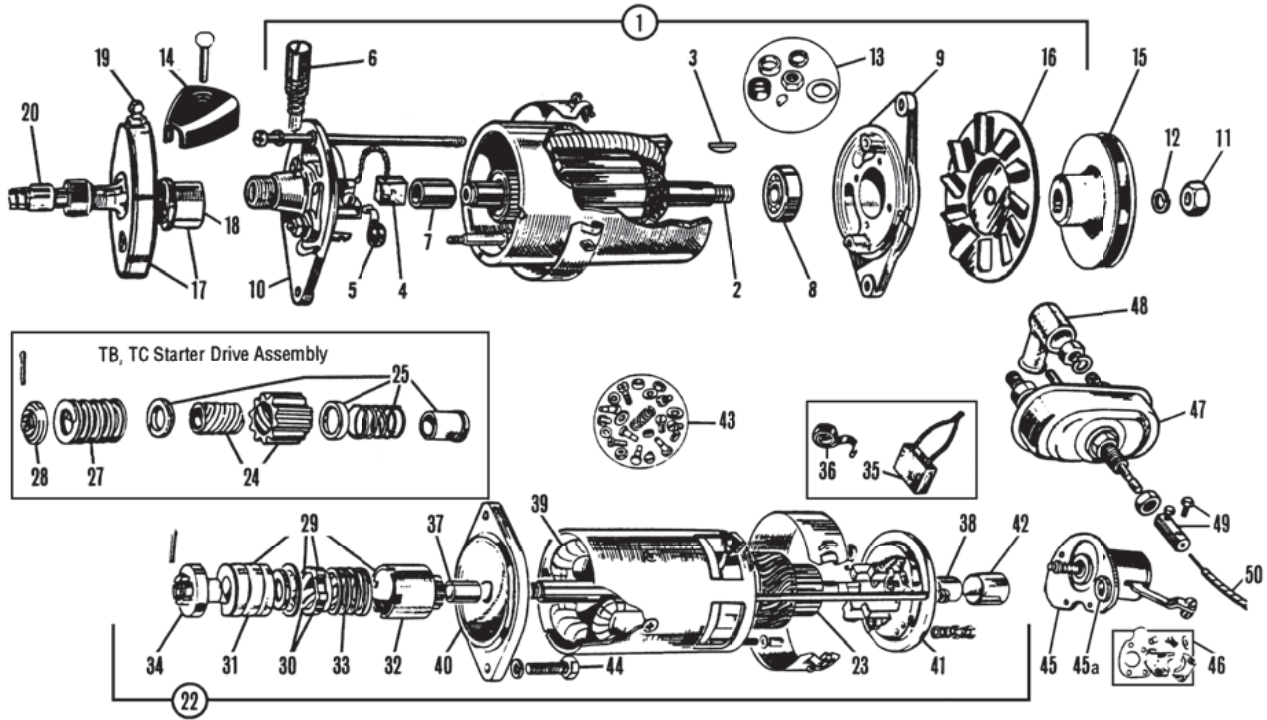

iii. Part Number Price £ea. Description Req. Details

Dynamo

1	EL177	£333.10	DYNAMO, recon, exchange	1	TB & TC
	AEJ49	£112.40	DYNAMO, new	1	TB & TC
			(Replacement type with Lucar terminals)		TD & TF
2	NCA		ARMATURE, dynamo	1	

Note: TA dynamos are no longer available.

3	327-030	£0.97	KEY, armature shaft	1	all models
4	147-100	£2.30	BRUSH SET, dynamo	1	TC
	GGB105	£2.00	BRUSH SET, dynamo	1	TD & TF
5	125-200	£10.60	SPRING SET, dynamo brush	1	all models
6	147-900	£31.65	OILER, dynamo	1	
7	148-000	£9.10	BUSH, dynamo	1	TC
	7H5390	£5.60	BUSH, dynamo	1	TD & TF
8	125-200	£10.60	BEARING, dynamo	1	TC
	18G8619	£6.10	BEARING, dynamo	1	TD & TF
9	148-100	NCA	PLATE, drive end	1	TC
	147-300	NCA	PLATE, drive end	1	TD & TF
10	147-500	NCA	PLATE, commutator end	1	
11	AJD8207Z	£1.03	NUT, armature shaft	1	TC
	NT607041	£0.66	NUT, armature shaft	1	TD & TF
12	146-500	NCA	LOCK WASHER, armature shaft	1	TC
	GHF334	£0.24	LOCK WASHER, armature shaft	1	TD & TF
13	NCA		SUNDRY PARTS KIT	1	TD & TF
14	149-950	£34.70	COVER, dynamo terminal	1	TC
	433-625	£63.10	PULLEY/FAN, dynamo	1	
	433-655	NCA	PULLEY/FAN, dynamo*	1	early TD
15	433-660	£34.70	PULLEY, dynamo*	1	late TD & TF
16	17D11	£11.00	FAN, dynamo*	1	

*Note: The pulley & fan for early and late TD dynamos are interchangeable.

17	PWT923	£205.20	GEARBOX, tachometer reduction	1	TA
	27H210	£84.50	GEARBOX, tachometer reduction*	1	TB, TC, TD, TF
18	360-040	£9.85	COUPLING KIT, gearbox to dynamo	1	
19	328-510	£2.20	GREASE NIPPLE, tachometer	1	reduction gearbox to dynamo

*Note: The TC reduction gearbox can be fitted to TA & TB's when a tachometer cable with push-on tachometer end & screw-on dynamo end is used (part no. 331-045).

20	331-035	£56.20	CABLE, tachometer, 48"	1	
			(Push-on both ends).		TA & TB
	331-045	£56.20	CABLE, tachometer, 48"	1	
			(Push-on 'tacho' end & screw-on dynamo end).		
	MM331-170	£40.80	CABLE, tachometer, 48"	1	TC, RHD TD & TF
	331-056	£32.40	CABLE, tachometer, 40"	1	TD & TF, LHD

iii. Part Number Price £ea. Description Req. Details

Starter Motor

22	EL178	£295.00	STARTER, reconditioned	1	TB & TC
	GEU9405	£75.00	STARTER, new	1	TD & TF

Note: TA starters are no longer available.

23	7H5050	NCA	ARMATURE, starter	1	TD & TF
24	7H5008	£35.90	DRIVE, starter	1	
25	070062	NCA	KIT, starter drive retaining	1	TB & TC
27	7H5007	£9.62	SPRING, main	1	
28	503527	£20.40	NUT	1	
29	NCA		DRIVE, starter	1	
30	148-900	NCA	SLEEVE & NUT	1	
31	7H5045	£4.43	SPRING, main	1	TD & TF
32	67H5010	£20.50	PINION	1	
33	501711	NCA	SPRING, pinion	1	
34	503527	£20.40	NUT	1	TF & replacement starters
35	GSB103	£4.88	BRUSH SET, starter	2	TB & TC
	GSB102	£4.10	BRUSH SET, starter	1	TD & TF
36	27H2291K	NCA	SPRING SET, starter brush	1	TB & TC
	509819A	NCA	SPRING SET, starter brush	1	TD & TF
37	244714A	£3.35	BUSH, drive end	1	TB & TC
	7H5049	£2.10	BUSH, drive end	1	TD & TF
38	242958A	£3.50	BUSH, commutator end	1	TB & TC
	511141	£1.99	BUSH, commutator end	1	TD & TF
39	NCA		FIELD COIL SET	1	TB & TC
40	NCA		PLATE, drive end, with bush	1	
	NCA		PLATE, drive end, with bush	1	
41	NCA		PLATE, comm. end, with brushes	1	TD & TF
42	NCA		CAP, armature end	1	
	NCA		SUNDRY PARTS KIT	1	
44	320-510	£1.03	BOLT, starter to blocks	2/3	all models, (TB-TC uses 3)
	145-710	£55.70	SWITCH, starter	1	TA
45	145-700	£164.20	SWITCH, starter	1	
45a	161-400	£8.56	BUSH, rubber	1	TB & TC
46	150-100	£40.00	COPPER CONTACT SET	1	
47	3H949	£27.50	SWITCH, starter	1	
48	8G548	£1.20	RUBBER BOOT, switch terminals	2	TD & TF
49	3H950	£10.00	COUPLING, cable to switch	1	
50	NCA		CABLE, starter switch	1	see batteries on page 33

Starting Handles

Authentic reproductions with brass handle. Very handy for adjusting valves, and, for starting the car.

NI	386-140	£45.00	STARTING HANDLE	1	TA-TB & TC
NI	386-150	£76.80	STARTING HANDLE	1	TD & TF

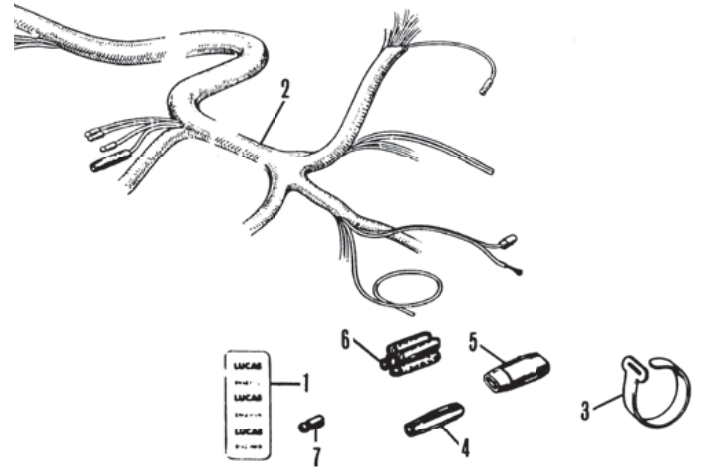
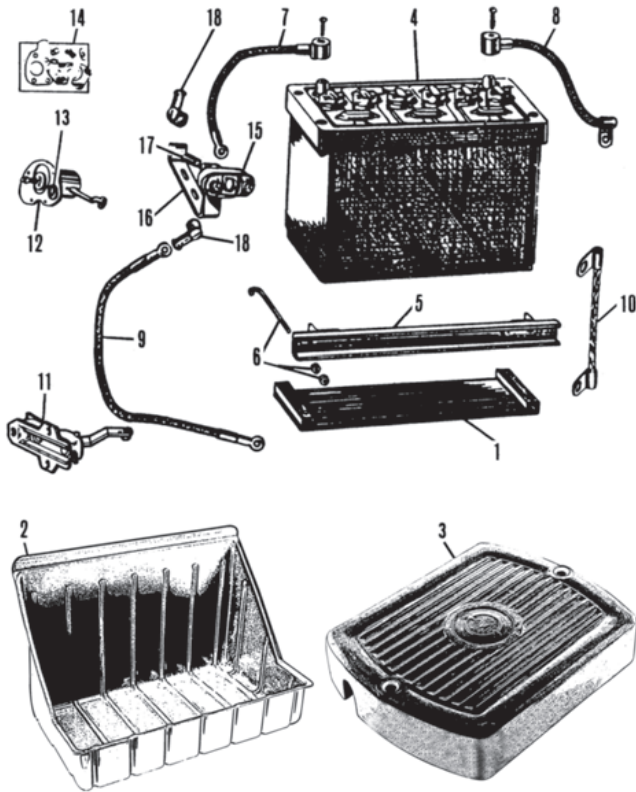

iii. Part Number Price £ea. Description Req. Details

Batteries/Fittings, Cables & Switches

Note: See the Accessories section for further details of battery trays.

1	407-710	£30.00	BATTERY TRAY, wooden	1	TD & TF (as original)
2	AM7301	£35.00	LINER, battery tray, (accessory)	1	TD & TF (photograph) (This clever - yet functional item, completely hides all but the most terminal symptoms of battery box plague. Ribbed for extra strength, this batter tray not only protects against corrosion, but also makes cleaning around the battery much easier).
3	BHA4140	£75.30	COVER, battery, 6 volt	2	TA & TB (& MGA)
4	GBY3031D11	£80.00	BATTERY, 6 volt, 63 A/hr, dry	2	TA & TB
	GBY3031W11	£80.00	BATTERY, 6 volt, 63 A/hr, wet	2	TC-TD & TF
	GBY242D	£158.00	BATTERY, 12 volt, 65 A/hr, dry	1	
	GBY242X	£157.50	BATTERY, 12 volt, 68 A/hr, wet	1	

Note: Due to delivery restrictions of hazardous goods, wet batteries can only be delivered by road and sea carrier to UK and mainland Europe. Dry batteries can be delivered worldwide, customers must arrange their own filling of dry batteries with suitable electrolyte and initial charge.

5	407-700	£35.60	BRACKET, battery securing	1	TD & TF
6	407-618	£8.65	BOLT & NUT SET, battery mounting	1	TD & TF (2 of each)
7	332-050	£44.00	CABLE, battery to starter	1	TC
	332-040	NCA	CABLE, battery to switch	1	TD & TF
8	131113	£13.00	CABLE, battery to earth	1	TC
	332-020	NCA	CABLE, battery to earth	1	TD & TF
9	AHA7776	£15.25	CABLE, switch to starter	1	
10	2K6167	£8.70	CABLE, engine earth	1	all models
11	145-710	£55.70	SWITCH, starter	1	TA
12	145-700	£164.20	SWITCH, starter	1	
13	161-400	£8.56	BUSH, rubber	1	TB & TC
14	150-100	£40.00	CONTACT SET, starter switch	1	
15	3H949	£27.50	SWITCH, starter	1	
16	AHH5002X	£11.60	BRACKET, starter switch	1	TD & TF
17	3H950	£10.00	COUPLING, cable to switch	1	
18	8G548	£1.20	RUBBER BOOT, switch terminals	2	

iii. Part Number Price £ea. Description Req. Details

Wiring Looms & Connectors

All of our T-series wiring looms feature original style braided cloth binding over original type lacquer-braided individual wires. These are colour-coded to original specifications and include required connectors. As was the case with factory replacement looms, neither the under-dash sub-loom connecting between various points on the dash itself, nor the TF headlamp pigtailed are included. For U.K. MOT purposes any car manufactured after 1936 must carry red rear/white front indicators or separate amber ones, our looms marked with (*) allows indicators to be incorporated in the side and tail lamps.

1	CRST122	£1.85	DECAL 'LUCAS'	a/r	
2	357-470	£167.00	WIRING LOOM, lacquer-braid (No wires for indicators).	1	TA & TB
	357-475	£262.20	WIRING LOOM, lacquer-braid* (With wires for side & tail lights).	1	
	357-480	£203.00	WIRING LOOM, lacquer-braid (No wires for indicators).	1	TC
	357-030	£222.50	WIRING LOOM, lacquer-braid (Wires for separate indicators).	1	
	357-040	£226.50	WIRING LOOM, lacquer-braid* (With wires for side & tail lights).	1	
	MM357-040	£310.80	WIRING LOOM, lacquer-braid* (USA spec. With wires for two separate indicator relays).	1	
	357-060	NCA	WIRING LOOM, lacquer-braid (Dash-mounted dip switch & no wires for indicators).	1	
	357-485	£241.80	WIRING LOOM, lacquer-braid (Dash-mounted dip switch & wires for separate indicators).	1	TD To (c)18882
	357-070	£241.60	WIRING LOOM, lacquer-braid* (Dash-mounted dip switch & with indicator wires to incorporate side & tail lights).	1	
	357-490	£230.70	WIRING LOOM, lacquer-braid (Foot dip switch & no wires for indicators).	1	TD From (c)18883
	357-495	£257.00	WIRING LOOM, lacquer-braid (Foot dip switch & wires for sep. indicators).	1	
	357-080	£246.00	WIRING LOOM, lacquer-braid* (Foot dip switch & with indicator wires to incorporate side & tail lights).	1	
	357-090	£246.00	WIRING LOOM, lacquer-braid	1	TF
3	2K6640	£3.62	STRAP, wire tie-down	a/r	rubber covered
4	104618	£0.31	WIRE CONNECTOR, 1 way	a/r	
5	RTC603A	£0.40	WIRE CONNECTOR, 2 way	a/r	
6	161-710	£10.24	WIRE CONNECTOR, 5 way	a/r	
7	003632	£0.32	BULLET CONNECTOR	a/r	
NI	GAC9906X	NCA	TAPE, (non adhesive), black	a/r	
NI	GAC9907X	NCA	TAPE, (non adhesive), blue	a/r	
NI	MQC1001	£3.44	TAPE, (self adhesive), black	a/r	
NI	MQC1000	£4.88	TAPE, (self adhesive), blue	a/r	

*Note: These looms also require: 1 Relay (3H1454), 1 Flasher unit (GFU2101) & 1 Turn switch (AMK5607) plus, 1 Turn switch Knob (27H5511) & a quantity of 2 'double filament' bulb holders (157-600) for front side lights.

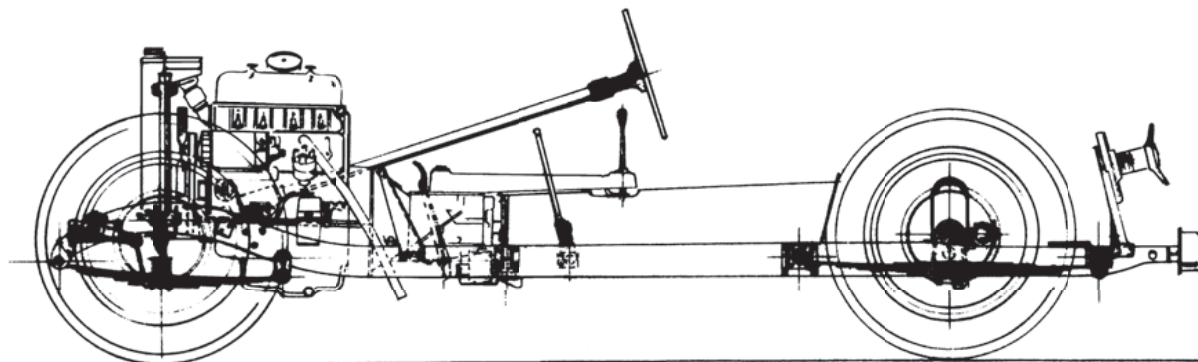
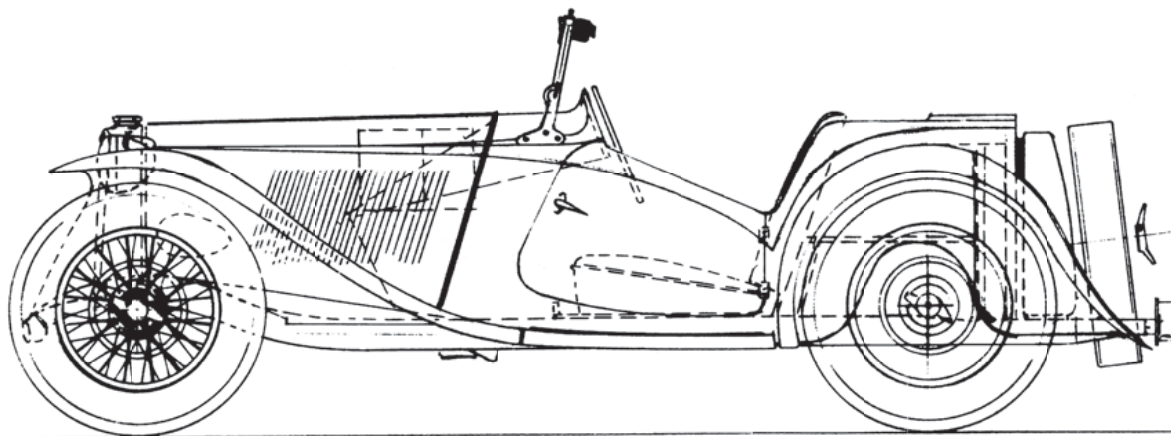

iii. Part Number Price £ea. Description Req. Details

Ignition System

Note: See the Accessories section for further details.

1	143-000	£144.00	DISTRIBUTOR, Lucas replacement type 1	1	TC & early TD
	143-000X	£259.00	DISTRIBUTOR, original type, recon/exch. 1	1	late TD & TF
	143-010	£144.00	DISTRIBUTOR, Lucas replacement type 1	1	
	143-010X	£287.70	DISTRIBUTOR, original type, recon/exch. 1	1	
2	153-030	£40.80	CAP, distributor	1	
	AAA4772	£13.30	CAP, distributor	1	TB-TC-TD & TF
3	GRA2101	£1.80	ROTOR ARM	1	all models
	GRA2101HQ	£7.50	ROTOR ARM, high quality	1	
4	163-915	£23.40	PLATE, with condenser	1	TA
5	163-700	£36.70	PLATE KIT, with condenser & points	1	TB-TC-TD & TF
6	163-895	£25.50	CONDENSER	1	TA
7	163-900	£8.34	CONDENSER, screw-on type	1	dist. no. 40367 & 40368
8	152-230	£5.00	POINT SET	1	TA
9	GCS112	£7.70	POINT SET	1	TB-TC-TD & TF
10		NCA	CAM, distributor	1	
11	152-300	£8.90	SPRING, distributor, pair	1	dist. no. 40367 & 40368
12		NCA	WEIGHT, distributor	2	
13	168-008	£26.40	BUSH SET, 2 bushes	1	dist. no. 40048 & 40162
14	AUC3233	£3.22	WASHER, copper	1	
15	606895	£22.00	BUSH, distributor	1	dist. no. 40367 & 40368 D/H
		NCA	BUSH, distributor	1	dist. no. 40368 A/B
16	163-710	£89.56	CLAMP, distributor	1	TD To (e) 20941
17	433-540	£39.00	COTTER BOLT, distributor	1	TD From (e) 20942 & TF
18	433-520	£54.70	GEAR, distributor	1	TB-TC-TD & TF
19	325-010	£0.30	PIN, gear to shaft	1	
20	171-618	£39.00	IGNITION LEAD SET, complete	1	
	AAA5981M	£2.90	IGNITION LEAD, sold per metre, black	a/r	
21	171-530	£5.20	SPARK PLUG NUT	4	
22	105036	£1.55	COIL SCREW CONNECTOR	1	
23	17H5122	£1.34	DISTRIBUTOR CAP NUT	5	all models
24	214279A	£0.22	WASHER, brass	6	
25	171-540	£2.15	LEAD SEPARATOR	1	
26	GCL101	£13.00	COIL, modern screw type HT connection	1	
	143-210	£44.30	COIL, reproduction of original Q12	1	
27	CRST156	£2.45	DECAL 'LUCAS', coil	1	
28	152-110	£2.70	SPARK PLUG, 1/2" reach	4	TA-TB-TC & TD To (e) 22734
	N5C	£2.70	SPARK PLUG, 3/4" reach	4	TD From (e) 22735, TF
29	433-530	£28.60	LOCK BOLT, distributor	1	TB-TC & TD To (e) 20941

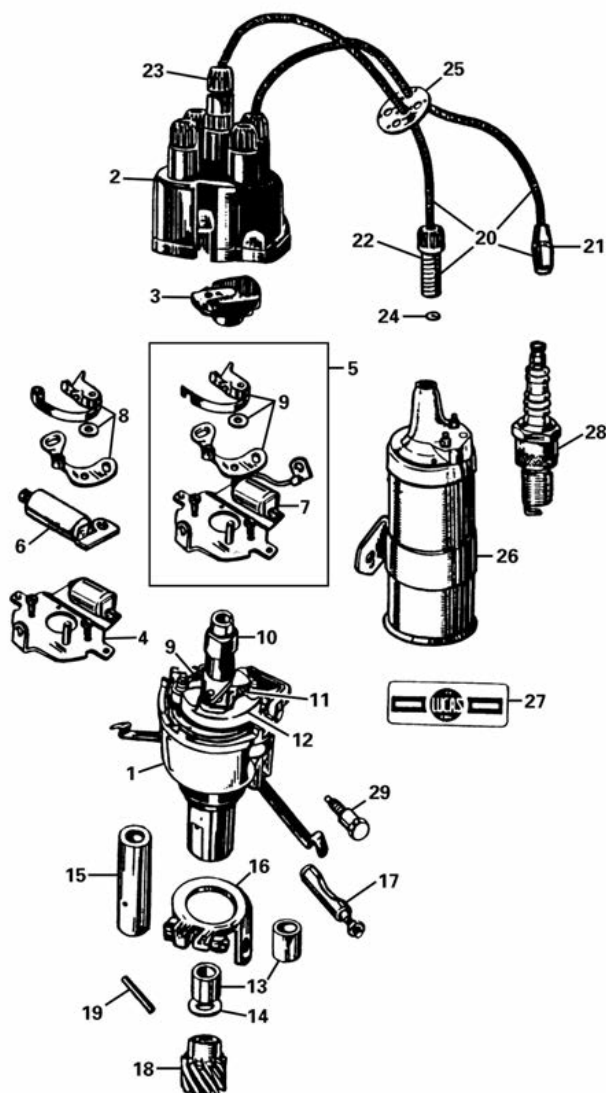

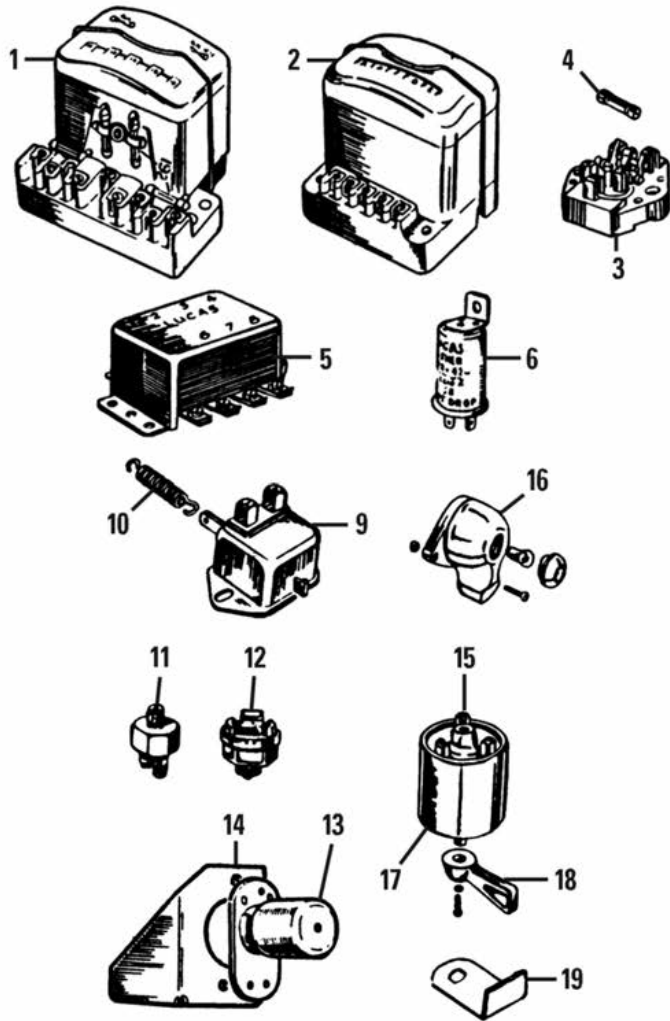

Switches, Fuses & Regulators

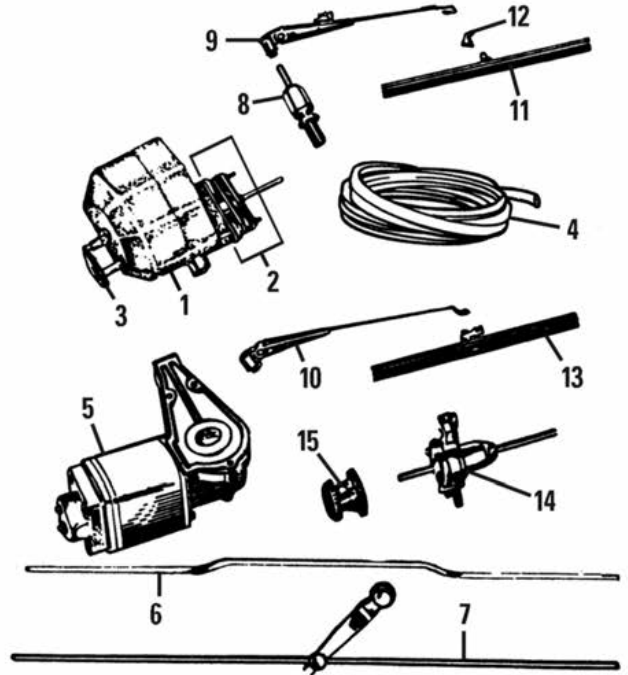

Wiper Motor, Arms & Blades

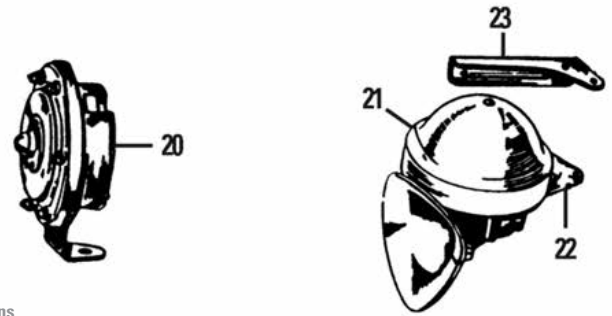

Horns

ill.	Part Number	Price £ea.	Description	Req.	Details
Switches, Fuses & Regulator					
1	141-900	£147.10	REGULATOR, 9 post	1	TC & TD To (c) 8141
2	3H1835	£22.00	REGULATOR, 5 post	1	TD From (c) 8142 & TF
3	1G2613	£14.70	FUSE BLOCK	1	}
4	GFS35X	£0.41	FUSE, 35 amp	a/r	
	GFS50X	£0.34	FUSE, 50 amp	a/r	
5	3H1454	£58.00	RELAY, turn signal indicator	1	all models
6	GFU2101	£7.20	FLASHER, turn signal, original	1	screw terminals
	GFU2103	NCA	FLASHER, turn signal, replacement	1	push-on terminals
9	141-600	£33.60	SWITCH, stop light	1	TA-TB & TC
10	150-700	£5.40	SPRING, stop light switch	1	}
11	13H2303	£7.20	SWITCH, stop light, (OE type screw)	1	
	C16062A	£4.00	SWITCH, stop light, (alternative Lucas)	1	TD & TF
12	BAU1074A	£6.00	SWITCH, reverse light	1	optional TD & TF
13	11G2007	£22.50	SWITCH, dip, floor-mounted	1	TD From (c) 18883
14	235-885	£32.50	MOUNTING BRACKET, dip switch	1	}
15	140-600	£91.79	SWITCH, turn signal**	1	
16	GLB987	£0.50	BULB, turn signal switch	1	TC '1949 EXU' models

**Note: Can be fitted to TA's & TB's.

17	AMK5607	£86.00	SWITCH, turn signal	1	TD & TF
18	11K9308	£3.22	HANDLE, turn signal switch	1	}
19	235-887	£6.30	BRACKET, turn signal switch	1	

Wiper Motor, Arms & Blades

1	145-300	£249.00	WIPER MOTOR, new	1	}
		NCA	BRUSH SET	1	
		NCA	COVER, with switch & handle	1	
2	145-305	£32.60	MOUNTING KIT (Includes: studs, spacers, end plate, nuts, & washers).	1	}
3	160-500	£10.60	HANDLE & NUT	1	
4	162-020	£10.10	WIPER WIRE, original type	1	

ill.	Part Number	Price £ea.	Description	Req.	Details
5	145-400	£307.80	WIPER MOTOR	1	TF
		NCA	MOTOR, without gear head	1	}
		NCA	MOUNTING PAD, wiper motor	1	
6	451-110	£34.70	CONNECTING BAR, wipers	1	TA-TB-TC & TD To (c) 22314
7	451-140	£16.57	CONNECTING BAR, wipers	1	TD From (c) 23315
8	160-600	£8.75	BEARING, idler	1/2	late TD uses 2
9	160-690	£22.00	WIPER ARM, LH	1	TA-TB-TC & TD
	160-790	£22.00	WIPER ARM, RH	1	TD To (c) 23314
	160-700	£22.00	WIPER ARM, LH	1	TD From (c) 23315
	160-800	£22.00	WIPER ARM, RH	1	}
10	161-050	£19.00	WIPER ARM	2	
11	160-300	£7.25	WIPER BLADE	2	TA-TB-TC & TD
12	160-400	£1.03	RUBBER RETAINER, wiper blade	2	}
13	160-900	£9.05	WIPER BLADE	2	
14		NCA	WHEEL BOX, LH, with switch	1	TF
		NCA	WHEEL BOX, RH	1	}
15	160-520	NCA	KNOB, wiper control	2	

Horns

Note: See the Accessories catalogue for further details.

20	165-900	£125.00	HORN, (exact repro. of TC original)	1	TA-TB & TC
21	1B9008	£32.90	HORN, high note, Lucas replacement, RH	1	}
	1B9007	£32.90	HORN, low note, Lucas replacement, LH	1	
22	160-200	£19.80	BRACKET, horn mounting, (flexible)	2	}
23	AAA2107	£24.00	BRACKET, horn, on bulkhead, RH	1	
	AAA2088	£24.00	BRACKET, horn, on bulkhead, LH	1	

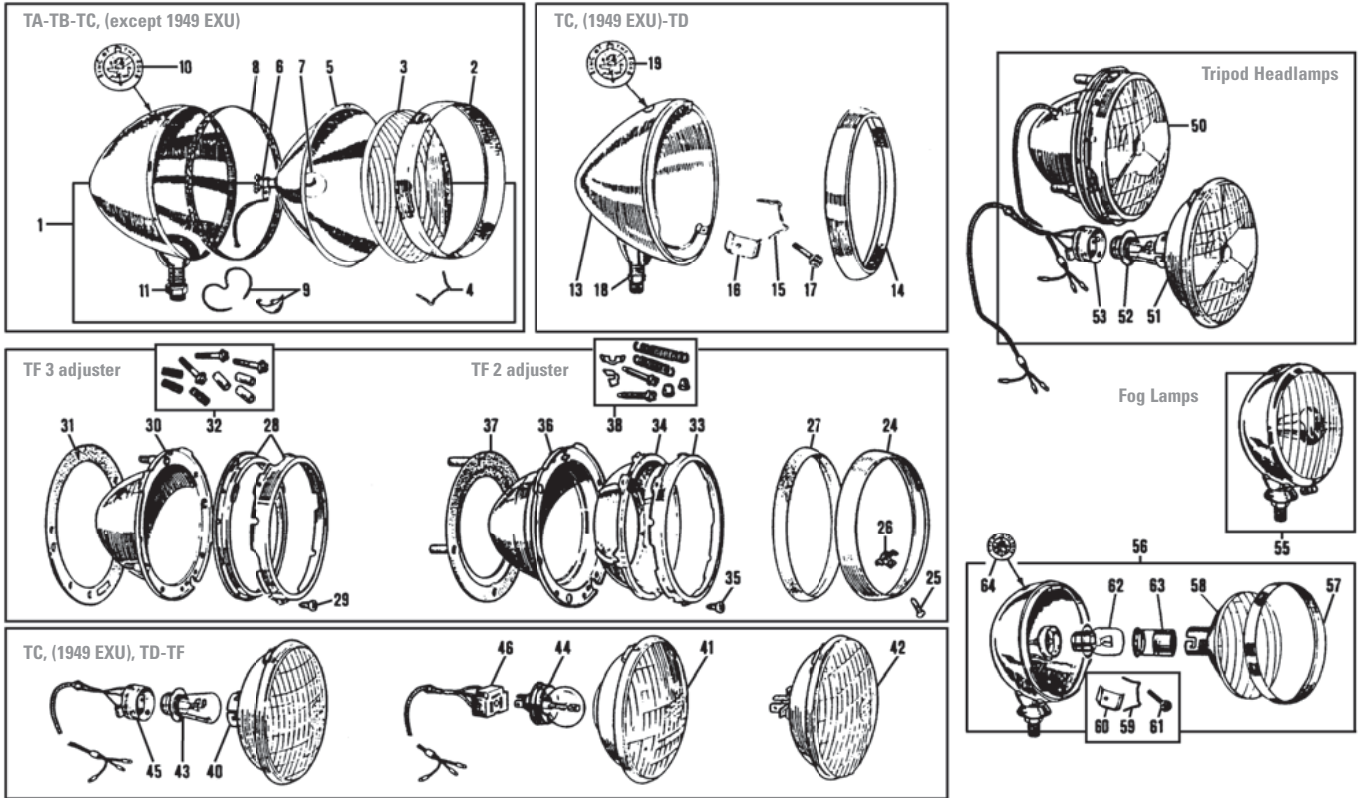

iii. Part Number Price £ea. Description Req. Details

Headlamps & Fog Lamps

Headlamps: TA-TB & TC except 1949 EXU models

1	169-018	NCA	HEADLAMP, 8" diameter	2	later TC type
2	156-410	£41.80	RIM, chrome	2	
3	171-120	£98.65	GLASS LENS	2	
4	156-500	£1.03	WIRE CLIP, lens to rim	8	
5	171-130	NCA	REFLECTOR UNIT, with socket	2	
6	171-150	£23.90	SOCKET, reflector	2	
7	170-400	£4.27	BULB, original headlamp	2	
8	281-098	£16.65	SEAL SET, 2 rubber seals	1	
9	154-500	£15.70	RETAINER, clip and wire	2	
10	154-910	£20.80	MEDALLION, "King of the Road"	2	
11	146-300	£3.91	NUT, headlamp to bracket	2	

Headlamp Buckets: TC 1949 EXU models & TD

13	143-310	£138.80	BUCKET, chrome with Lucas medallion	2	for 143-310 only
	143-300	£102.83	BUCKET, painted without medallion	2	
14	156-400	£38.80	RIM, chrome	2	
15	156-500	£1.03	WIRE CLIP, light unit to rim	8	
16	156-000	£4.93	CLIP, shell to rim	2	
17	158-000	£1.60	SCREW, clip to shell, chrome	2	
18	146-300	£3.91	NUT, headlamp to bracket	2	
19	154-910	£20.80	MEDALLION, "King of the Road"	2	

Headlamp Buckets: TF

24	142001	£15.20	CHROME RIM, outer	2	all TF models
25	RTC465	£0.42	SCREW, rim retaining	2	
26	37H7421A	£1.55	CLIP, rim retaining	2	
27	3H2962	£2.80	DUST EXCLUDER, rubber	2	
28	17H5205	£15.80	INNER RIM, 2 pieces	2	
29	AB606021	£0.20	SCREW, rim retaining	6	
30	7H6838	£20.10	HEADLAMP BUCKET, 3 adjuster type	2	TF models with 3 adjusters
31	3H1031	£3.30	SEAL, bucket to body	2	
32	17H5394K	£3.80	ADJUSTER KIT (3 screws, 3 springs & 3 sleeves).	2	
33	515218A	£5.00	OUTER MOUNTING RING, chrome	2	TF models with 3 adjusters (replacement type)
34	SML4	£7.50	INNER MOUNTING RING	2	
35	AB606021	£0.20	SCREW, rim retaining	6	
36	SML3	£13.00	HEADLAMP BUCKET, 2 adjuster type	2	
37	13H565	£2.50	SEAL, bucket to body	2	
38	BHM7058	£4.20	ADJUSTER KIT (2 screws, 2 ferrules, 2 springs & 2 clips).	2	

iii. Part Number Price £ea. Description Req. Details

Headlamp Lenses & Bulbs: TC 1949 EXU models, TD & TF

40	GLU501	£40.00	LIGHT UNIT, BPF lamp, RHD	2	Note: LHD BPF units are not available. Use either item 41 (Part No. 27H4146A) or Tripod lamp units, item 50 (Part No: 506372X).	
41	27H4146A	£21.30	LIGHT UNIT, P45T asymmetric, LHD	2		
42	GLU101	NCA	LIGHT UNIT, sealed beam, RHD	2		
	BMK2508	NCA	LIGHT UNIT, sealed beam, LHD	2		
43	GLB414	£3.30	BULB, BPF, clear, RHD	2		
	GLB415	£8.00	BULB, BPF, clear, LHD	2		
	GLB409X	NCA	BULB, BPF, cadmium yellow, LHD	2		
44	GLB410	£2.75	BULB, P45T, clear	2		
	GLB411	NCA	BULB, P45T, cadmium yellow	2		
	GLB2983	£8.65	BULB, P45T, halogen, clear	2		
45	27H2333	£12.30	ADAPTOR & CABLES	2		BPF units
46	BAU2110	£6.30	ADAPTOR & CABLES	2		P45T & sealed beam units

Tripod Headlamps

50	506370X	£99.60	TRIPOD HEADLAMP (Complete unit with bulb & adaptor).	2	RHD models
51	LU554308	£66.90	LIGHT UNIT	2	
52	GLB414	£3.30	BULB	2	
53	27H2333	£12.30	ADAPTOR & CABLES	2	LHD models
50	506372X	£96.40	TRIPOD HEADLAMP (Complete unit with bulb & adaptor).	2	
51	LU555296	£67.00	LIGHT UNIT	2	
52	GLB415	£8.00	BULB	2	
53	27H2333	£12.30	ADAPTOR & CABLES	2	

Fog Lamps

55	169-020	£425.30	FOG LAMP (Exact reproduction of FT27 assembly).	1	TA-TB & TC To (c)4738	
56	169-000	NCA	FOG LAMP (Exact reproduction of Lucas SFT 462).	1		
57	156-420	NCA	RIM, chrome	1		
58	171-140	NCA	LIGHT UNIT	1		
59	154-200	NCA	WIRE CLIP, light unit to rim	3		TC From (c)4739
60	156-000	£4.93	CLIP, shell to rim	1		
61	323-090	£1.50	SCREW, clip to shell, chrome	1		
62	GLB382	£0.60	BULB	1		
63	171-410	NCA	BULB SHIELD	1		
64	154-920	£10.90	MEDALLION, 'King of the Road'	1		

ill.	Part Number	Price Eea.	Description	Req.	Details
Side Lamp: all models					
1	143-400	£132.60	SIDE LAMP, 'King of the Road' medallion	2	
2	281-068	£4.37	PAD SET, lamp to wing	1	2 pads
3	157-600	£34.70	BULB HOLDER, double contact, parallel	2	included with side lamp
	157-601	£31.50	BULB HOLDER, double contact, offset	2	not inc. with side lamp
	157-590	£16.80	BULB HOLDER, single contact	2	not inc. with side lamp
4	170-900	£2.15	BULB, double contact, parallel	2	included with side lamp
	GLB380	£0.50	BULB, double contact, offset	2	not inc. with side lamp
	GLB207	£0.55	BULB, single contact	2	not inc. with side lamp
5	146-100	£2.77	SCREW, lens retaining	2	chrome
6	281-088	£2.15	RING SET, lens sealing	1	2 rubber rings
7	157-750	£16.00	LENS, glass	2	with chrome rim
8	154-900	£4.27	MEDAL, red plastic	2	'King of the Road'

Rear Turn Signal Lamp

TC - 1949 USA Export Models Only

10	143-975	£194.00	REAR TURN SIGNAL LAMP	2	
11	143-985	NCA	BRACKET, rear turn signal	2	

Number Plate Lamp

TC - 1949 USA Export Models Only, TD & TF

12	127916	£21.60	NUMBER PLATE LAMP, chrome	1	
	127916Z	£13.00	NUMBER PLATE LAMP, plastic	1	
13	502264	£9.76	COVER	1	
14	17H5385	£1.80	SCREW, cover	1	
15	601721A	£4.42	LENS, glass	1	
16	GLB989	£0.71	BULB	1/2	
17	57H5368	£3.22	SEAL, rubber	1	

Tail Lamp Assembly

TA To (c)1789

20	143-890	£68.90	TAIL LAMP, round	2	
21	GLB207	£0.55	BULB, original tail lamp	4	

TA From (c)1790, TB & TC

24	143-900	£94.55	TAIL LAMP	2	chrome, original "D" lamp
25	154-600	£12.00	LENS, split "D", red	2	
26	143-920	£10.50	SIDE LENS, clear	2	
27	143-930	£3.22	GASKET, side lens	2	
28	143-940	£2.52	GASKET, split "D" lens	2	
29	GLB380	£0.50	BULB, replacement tail lamp	2	
	GLB207	£0.55	BULB, original tail lamp	4	

Note: See 'Body Panels & Fittings - Chassis Frame' for mounting plates.

TD, Up To (c)21302

30	157-908	£68.50	TAIL LAMP	2	
31	501934X	£12.90	GLASS LENS, tail lamp	2	
32	157-920	£12.40	RIM, chrome	2	
33	157-800	£4.43	SCREW, rim to wing, chrome	4	
34	GLB380	£0.50	BULB	2	
35	158-310	£31.65	SOCKET & PLATE	2	
36	280-510	£9.50	BODY	2	

TD, From (c)21303, TF

38	3H1814	£18.60	TAIL LAMP	2	
39	7H5182	£2.10	RIM, chrome	2	
40	7H5183	£6.46	LENS, glass	2	
41	GLB380	£0.50	BULB	2	
42	17H5426	£13.30	SOCKET	2	
43	37H5481	£2.60	BODY	2	
44	406-900	£31.65	ADAPTOR, lamp to wing, chrome	2	
45	281-338	£5.20	PAD SET, adaptor to wing	1	includes 2 pads

Reflector, TD & TF

46	144-700	£13.80	REFLECTOR	2	late TD MkII
47	144-600	£15.60	REFLECTOR	2	TF

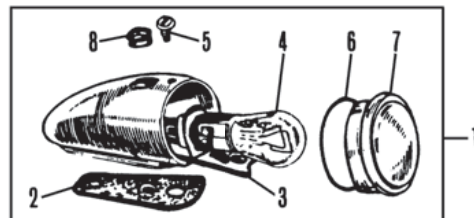

Side Lamp: All Models

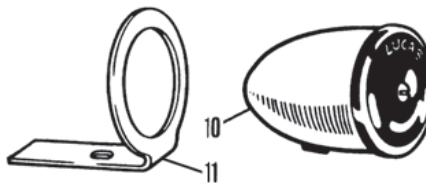

Rear Turn Signal Lamp

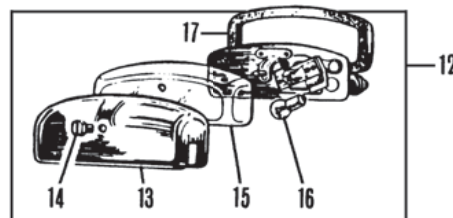

Number Plate Lamp

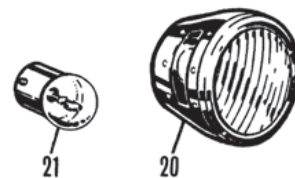

Tail Lamp Assembly, TA To (c) 1789

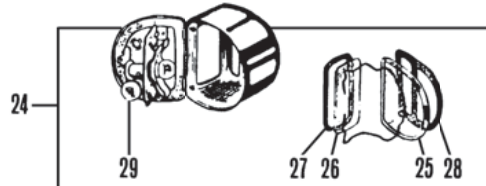

Tail Lamp Assembly, TA From (c) 1790, TB-TC

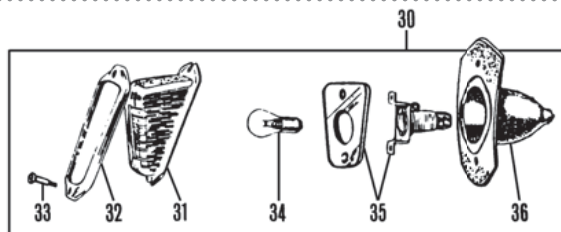

Tail Lamp Assembly, TD To (c) 21302

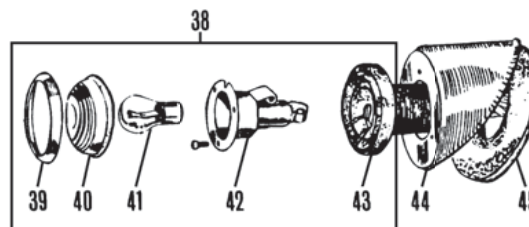

Tail Lamp Assembly, TD From (c) 21303, TF

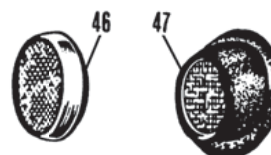

Reflector, TD & TF

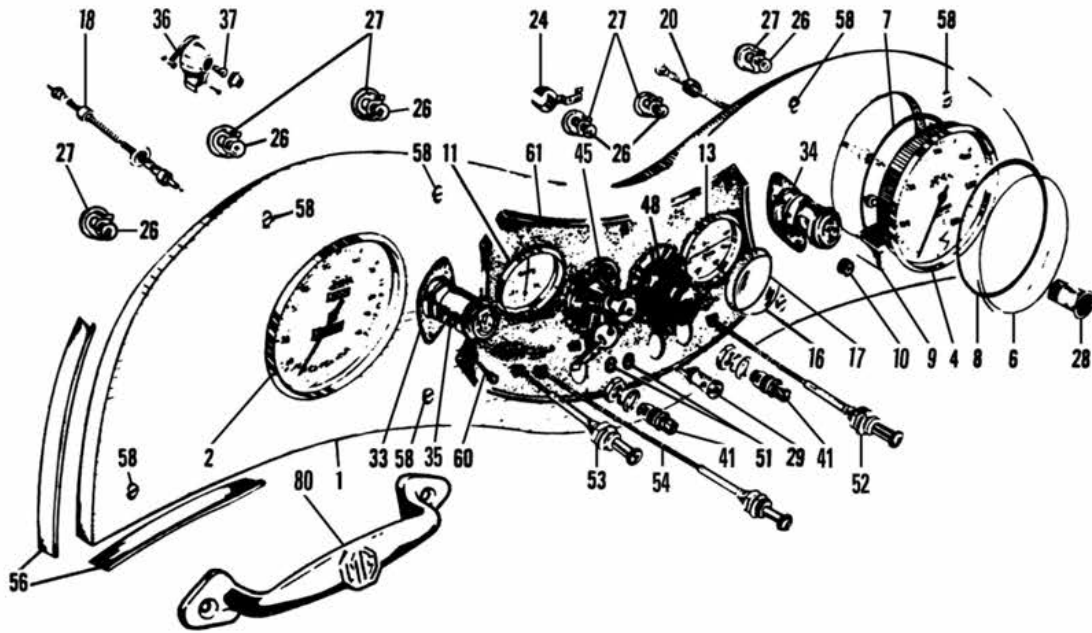

MG TA, TB, TC

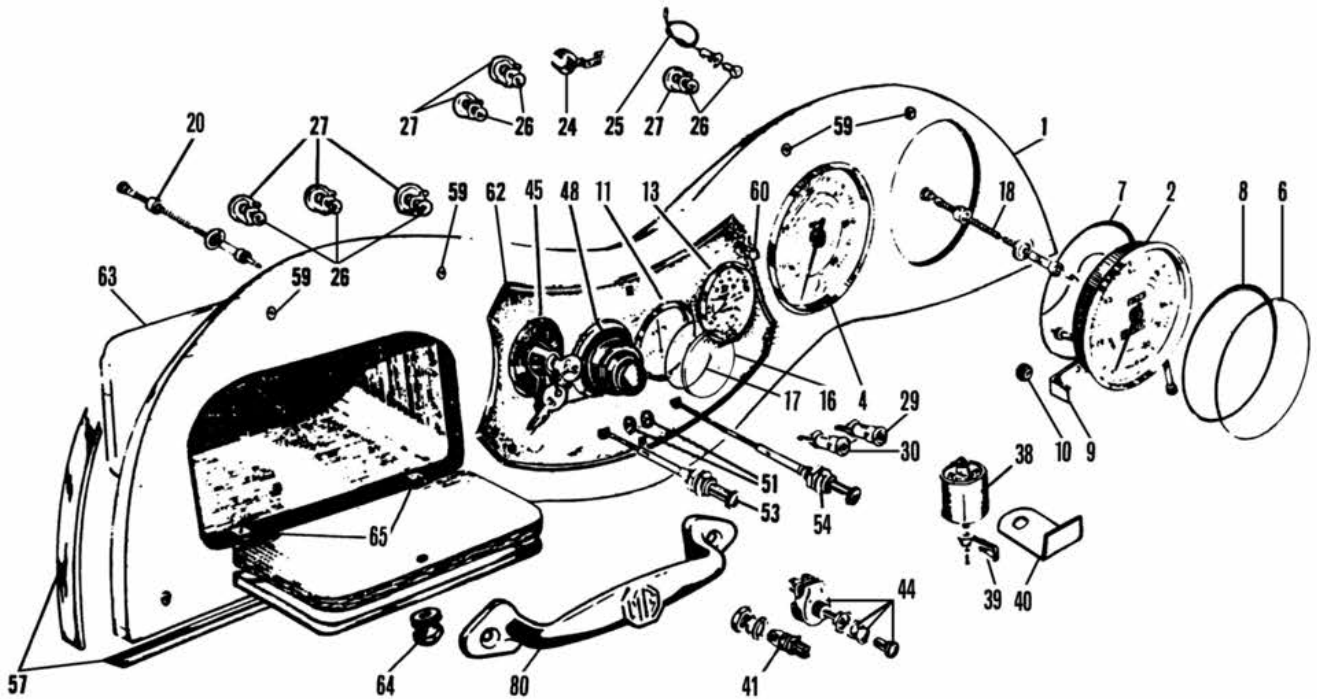

MG TD

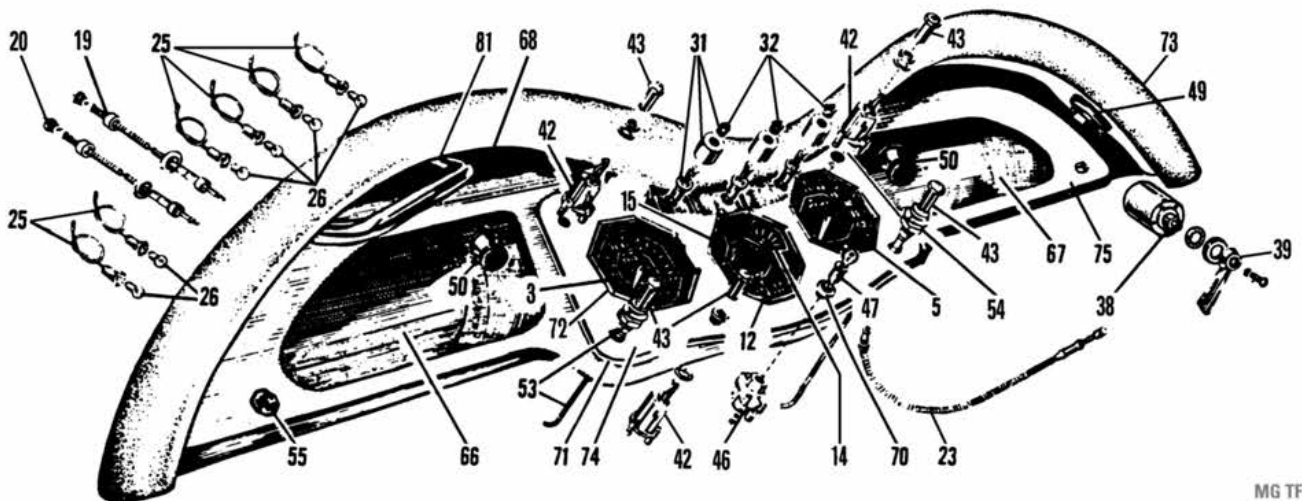

MG TF

ill. Part Number Price £ea. Description Req. Details

Dashboard, Switches, Instruments & Cables

Dashboards, TA-TB-TC & TD

We offer dashboards both in a finished veneer or a plain plywood. TA's-TB's & TC's to approximately (c)5000 were originally fitted with the finished veneered dashboards. TC's from approximately (c) 5000 and all TD's were fitted with the plain plywood.

1	456-885	£247.90	DASHBOARD, finished veneer	1	TA & TB
	456-895	£117.64	DASHBOARD, plywood	1	
	233-635	£280.00	DASHBOARD, finished veneer	1	TC
	456-890	£120.61	DASHBOARD, plywood	1	
	233-530	£544.00	DASHBOARD, finished walnut veneer	1	TD RHD
	233-570	£135.00	DASHBOARD, plywood	1	
	233-645	£515.00	DASHBOARD, finished walnut veneer	1	TD LHD
	233-510	£139.00	DASHBOARD, plywood	1	

Instruments & Cables

Our 'replica' speedometers & tachometers, while not quite original enough to call 'reproduction', are excellent replacements for the completely obsolete TC and early TD flat-faced instruments. They can also be used to replace the obsolete dish-faced TD instruments if required. We no longer offer rebuilding service on speedometers, tachometers or clocks.

2	360-460	£201.40	REPLICA SPEEDOMETER	1	TC & TD To (c) 10778
		NCA	SPEEDOMETER, repro of original	1	TD From (c) 10779
3		NCA	SPEEDOMETER, repro of original	1	TF
		NCA	METAL FACE SET, tach & speedo	1	TC & TD To (c) 10778
4	360-470	£186.30	REPLICA TACHOMETER	1	
		NCA	TACHOMETER, repro of original	1	TD From (c) 10779
		NCA	TACHOMETER, repro of original	1	TF
6	502268	£12.80	GLASS, tach & speedo	2	TA-TB-TC & TD
	AJH5177	£5.18	GLASS, instrument cluster	3	TF
7	280-860	£2.15	'O' RING, tach & speedo to dash	2	TA-TB-TC & TD
8		NCA	'O' RING, lens to tach & speedo	2	
9	361-030	£11.60	BRACKET, tach & speedo	2	TA-TB-TC & TD To (c) 10778
10	MM361-020	£3.05	NUT, brass, bracket to tach & speedo	4	TA-TB-TC & TD
11	360-500	£235.60	AMMETER, -20-20+, reproduction	1	TA-TB-TC & TD To (c) 10778
	360-510	£235.60	AMMETER, -30-30+, reproduction	1	TD From (c) 10779
12	360-520	NCA	AMMETER	1	TF
13	360-490	£194.00	GAUGE, oil pressure	1	TA-TB-TC & TD To (c) 13913
	360-070	£290.30	GAUGE, oil pressure/water temp	1	TD From (c) 13914
14	360-250	NCA	GAUGE, oil pressure	1	TF
	360-100	£269.00	GAUGE, water temperature	1	TA-TB-TC & TD (option)
15	360-160	NCA	GAUGE, water temperature	1	TF
	360-130	£264.20	GAUGE, oil temperature	1	TA-TB-TC & TD (option)
16	502269	£15.65	GLASS, 2" gauge	a/r	
17		NCA	'O' RING, lens to 2" gauge	a/r	TA-TB-TC & TD
	17H1642	£0.50	'O' RING, 2" gauge to dash	a/r	
18	331-135	£54.90	CABLE, speedometer, original (Push-on speedometer end).	1	TA-TB (5' 8")
	331-140	£42.80	CABLE, speedometer, original	1	TC & TD RHD (5' 8")
	331-150	£41.50	CABLE, speedometer, original	1	TD LHD (6'6")
19	331-140	£42.80	CABLE, speedometer, original	1	TF
20	331-035	£56.20	CABLE, tachometer, 48" (Push-on both ends).	1	TA & TB
	331-045	£56.20	CABLE, tachometer, 48" (Push-on tach & screw-on dynamo).	1	TA & TB
	MM331-170	£40.80	CABLE, tachometer, original	1	TC-TD & TF RHD

*Note: The TC reduction gearbox can be fitted to TA's & TB's if a push-on tachometer end & screw-on dynamo end tachometer cable is used.

	331-056	£32.40	CABLE, tachometer, original	1	TD & TF LHD
		NCA	CABLE, trip reset, replacement	1	TF
23	361-070	£4.42	BRACKET, dash lamp mounting	4	TA-TB-TC & TD To (c) 10778
25	161-918	£8.26	SOCKET & BULB	1/6	late TD & TF (late TD uses 1)
26	GLB987	£0.50	BULB, dash, screw base	a/r	
27	070066	£7.50	SOCKET, dash bulb, original gauge	6	TA-TB-TC & TD
28	142-600	£122.75	LAMP, fuel warning	1	TC
29	2H2838	£35.60	LAMP, ignition warning, red	1	TA-TB-TC & TD
30	142-210	£35.60	LAMP, warning, green	1/2	TD, (late TD uses 2)
31	37H5182	£22.00	LAMP, warning, with 3 lenses	3	
32	151-400	£3.80	LENS, red	1	TF
	AJG5046	£3.30	LENS, green	1	
	151-600	£3.80	LENS, blue	1	
33	144-500	£92.92	MAP LIGHT	1	
34	PWT1484	£91.79	COVER, 30mph warning lamp	1	TA-TB & TC
35	GLB207	£0.55	BULB, map light	2	

Switches & Miscellaneous Trim

36	140-600	£91.79	SWITCH, turn signal**	1	TC 1949 EXU models
37	GLB987	£0.50	BULB, turn signal switch**	1	

**Note: Can be fitted to TA's & TB's.

ill. Part Number Price £ea. Description Req. Details

38	AMK5607	£86.00	SWITCH, turn signal	1	TD & TF
39	11K9308	£3.22	HANDLE, turn signal switch	1	
40	235-887	£6.30	BRACKET, signal switch mounting	1	TD
41	141-000	£40.80	SWITCH, fog light, panel	1/2	TA-TB-TC & TD
42	3H3098	£22.50	SWITCH, light, panel & accessories	3	TF
43	150-908	£17.75	DASH KNOB SET, lettered, original style	1	
44	145-900	£138.90	SWITCH, panel light rheostat, with knob	1	
	145-907	£8.80	KNOB, push-on type	1	TD from (c) 10701
	145-905	NCA	KNOB, screw type	1	
	500513S	NCA	SCREW, (for part no. 145-905)	1	
45	141-510	£168.60	SWITCH, ignition/headlamp, with 2 keys	1	TA-TB-TC & TD
46	141-010	£115.19	SWITCH BODY, ignition	1	TF
47	24G1345	£8.00	BARREL & KEY, ignition	1	
	24G1345Z	£5.70	BARREL & KEY, ignition, aftermarket	1	
48	140-700	£94.55	SWITCH, horn/dip, reproduction	1	TA-TB-TC & TD to (c) 18882
	140-808	NCA	BUTTON, horn push	1	TD from (c) 18883
	233-950	£5.00	CHROME WASHER SET, behind horn push	1	TA-TB-TC & TD
49	2H3383	£17.00	BUTTON, horn push	1	TF
50	160-520	NCA	KNOB, wiper control	2	
51	NBEL147	£56.80	SOCKET SET, accessory plug	1	TA-TB-TC & TD
	NBEL148	£18.45	PLUG, optional accessory	1	
52	MM331-390	£51.80	SLOW RUNNING CABLE, original	1	TA-TB & TC
53	331-370	£76.90	STARTER CABLE, original	1	TA-TB & TC
	331-280	£30.65	STARTER CABLE, original	1	TD
	331-400	£33.30	STARTER CABLE, original	1	TF
54	331-380	£58.00	CHOKE CABLE, original	1	TA-TB & TC
	331-290	£34.70	CHOKE CABLE, original	1	TD
	331-410	£41.20	CHOKE CABLE, original	1	TF
55	408-400	£43.60	MEDALLION, dash	1	TF
56	454-100	£113.69	BEAD SET, dash	1	TA-TB & TC
57	454-110	£100.00	BEAD SET, dash and glove box	1	TD
58	323-838	£12.50	SCREW & WASHER SET, dash	1	TA-TB & TC, (8 of each)
59	323-848	£11.40	SCREW & WASHER SET, dash	1	TD, (8 of each)
60	321-478	£10.96	BOLT & NUT SET, instrument panel	1	TA-TB-TC & TD, (6 of each)
61	408-860	£215.00	PANEL, instrument cluster, black	1	TA-TB & TC
	408-865	£212.00	PANEL, instrument cluster, bronze	1	late TC
62	408-870	£215.00	PANEL, instrument cluster	1	
63	454-155	£33.50	GLOVE BOX	1	TD
64	408-190	£3.07	KNOB, glove box door	1	
65	406-910	£5.40	HINGE, glove box door	2	
66	454-350	£47.20	GLOVE BOX, LH	1	
67	454-360	£47.20	GLOVE BOX, RH	1	
68	456-105	£11.40	TOP, glove box, LH	1	
	456-125	£11.40	TOP, glove box, RH	1	TF
	456-085	£6.60	CORNER PANEL, rear cockpit, LH	4	
	456-075	£6.60	CORNER PANEL, rear cockpit, RH	4	
	456-095	£9.37	STARTING HANDLE COVER	4	
	451-765	£78.40	UNDER DASH SHIELD KIT***	1	TA & TB
	451-785	£80.30	UNDER DASH SHIELD KIT***	1	TC
	451-795	£83.45	UNDER DASH SHIELD KIT***	1	TD
	451-800	£47.20	UNDER DASH SHIELD	1	TF
	451-775	£70.00	UNDER DASH SHIELD H-FRAME	1	

***Note: Kits include all brackets, hardware, vinyl covering, board and instructions.

70	408-215	£22.35	BEZEL, ignition switch	1	
71	408-195	NCA	TRIM, cluster panel	1	
72	408-205	NCA	BEZEL, octagonal, for instruments	3	TF
73	280-595	£77.30	COWL RUBBER, uncovered	1	
74	408-895	£221.20	CLUSTER PANEL	1	
75	456-905	£307.40	DASH PANEL, steel	1	
80	229-101	£25.00	GRAB HANDLE, with MG motif	1	TA-TB-TC & TD
81	229-220	£84.46	GRAB HANDLE, curved	1	TF

Decals

Use these decals to replace, or restore the original items that were originally painted and directly silk screened.

215-100	£16.90	INSTRUMENT DECAL SET	1	TA-TB & TC
				TD To (c)10751

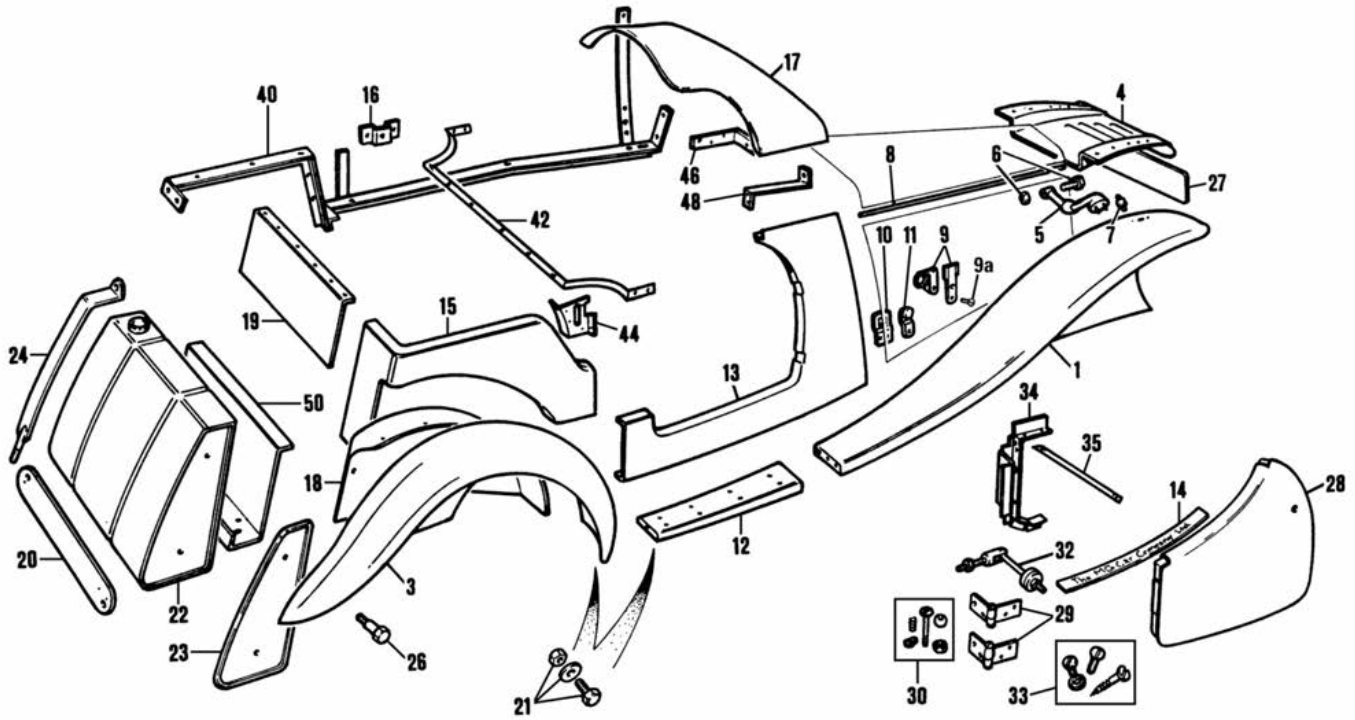

ill.	Part Number	Price £ea.	Description	Req.	Details
Body Panels, TA & TB					
1	456-510	£1,114.00	FRONT WING, RH	1	
	456-500	£1,114.00	FRONT WING, LH	1	
NI	236-210	£137.00	WING COVER SET, pair (These very practical black padded vinyl wing covers are specially tailored to fit your model. Protect that expensive finish from wayward spanners and greasy hands. Both left and right covers are supplied in the set).	2	TA-TC
3	450-000	£795.00	REAR WING, RH	1	TA To (c) 1090
	456-610	£784.00	REAR WING, RH	1	TA From (c) 1091 & TB
	450-005	£795.00	REAR WING, LH	1	TA To (c) 1090
	456-600	£784.00	REAR WING, LH	1	TA From (c) 1091 & TB
4	457-100	£248.00	SPLASH APRON, front	1	
5	407-390	£133.00	BRACKET, headlamp, RH	1	
	407-380	£133.00	BRACKET, headlamp, LH	1	
6	321-288	£11.96	BOLT & NUT SET, headlamp bracket	2	1 of each
7	328-175	£4.21	STUD, headlamp bracket	4	
8	453-280	£13.55	ROD, brass, side panel attaching	2	
9	406-855	£25.10	BONNET LATCH, RH	2] cadmium plated
	406-860	£25.10	BONNET LATCH, LH	2	
9a	158-018	£6.60	SCREW, bonnet latch	a/r	
10	406-810	£24.00	BRACKET, bonnet latch, on wing	4	
11	406-828	£24.20	BUFFER PLATE SET, bonnet	1	4 buffers & plates
12	450-010	£113.00	RUNNING BOARD, RH	1	
	450-015	£113.00	RUNNING BOARD, LH	1	
13	457-215	£189.90	FRONT QUARTER PANEL, RH	1	
	457-225	£189.90	FRONT QUARTER PANEL, LH	1	
14	451-398	£40.00	THRESHOLD PLATE SET, (pair) (2 plates etched with 'The MG Car Company Ltd').	1	
15	450-020	NCA	REAR QUARTER PANEL, RH	1	TA To (c) 1090
	450-025	£173.30	REAR QUARTER PANEL, RH	1	TA From (c) 1091 & TB
	450-030	£173.30	REAR QUARTER PANEL, LH	1	TA To (c) 1090
	450-035	£173.30	REAR QUARTER PANEL, LH	1	TA From (c) 1091 & TB
16	450-040	£8.00	BRACKET, rear side screen	2	
17	446-010	£397.00	SCUTTLE TOP	1	
18	457-210	£137.00	WHEEL ARCH, RH	1	
	457-200	£137.00	WHEEL ARCH, LH	1	
19	457-175	£37.00	REAR PANEL	1	between rear quarter panels
20	450-045	£37.80	BLANK PLATE, round lamps	1	TA To (c) 1789
	451-725	£44.00	BLANK PLATE, 'D' lamps	1	TA From (c) 1790 & TB
21	321-778	£26.40	BOLT & NUT SET	1	wing/running boards to body
	320-360	£0.80	SCREW 5/16 BSF x 3/4"	4	
	AJD8105Z	£0.18	NUT 5/16 BSF	8	
	AJD6308Z	£1.60	BOLT 3/8 BSF x 1"	4	
	AJD8106Z	£0.29	FULL NUT 3/8 BSF	4	Sub-components of kit
	AJD6124Z	£3.44	BOLT 1/4 BSF x 3"	4	part no. 321-778
	AJD8104	£0.34	FULL NUT 1/4 BSF	6	
	320-380	£1.24	BOLT 5/16 BSF x 1 1/4"	4	

ill.	Part Number	Price £ea.	Description	Req.	Details
22	456-760	£486.00	FUEL TANK, 36 5/8" wide	1	TA To (c) 1090
	456-765	£486.00	FUEL TANK, 31 5/8" wide	1	TA From (c) 1091 & TB
23	451-638	£172.20	END PANEL SET, fuel tank	1	2 chrome end panels
24	451-600	£27.00	STRAP, fuel tank, primed	2	
	450-055	£43.90	STRAP, fuel tank, chromed	2	optional
26	320-840	£15.55	BOLT, wing to fuel tank	2	
27	451-715	£20.40	NUMBER PLATE, blank, front	1	
28	446-015	£744.00	DOOR ASSEMBLY, RH	1] panelled
	446-020	£744.00	DOOR ASSEMBLY, LH	1	
29	401-858	£298.60	DOOR HINGE SET	1	4 hinges & mtg. hardware
30	401-878	£42.00	PIVOT BOLT SET, door hinge	1	complete set with balls
32	405-500	£16.70	DOOR CHECK	2	
33	323-868	£76.80	SCREW SET	1	for hinges, locks, strikers
34	450-060	£24.00	STRENGTHENER, door hinge, RH	1	
	450-065	£24.00	STRENGTHENER, door hinge, LH	1	
35	450-780	£6.30	DOOR TWIST STRIP	2	

Body Tub Steelwork

40	450-075	NCA	FRAME, body/chassis, LH	1	TA To (c) 1090
	450-080	£334.00	FRAME, body/chassis, LH	1	TA From (c) 1091 & TB
	450-085	NCA	FRAME, body/chassis, RH	1	TA To (c) 1090
	450-090	£334.00	FRAME, body/chassis, RH	1	TA From (c) 1091 & TB
42	450-095	NCA	STRENGTHENER, rear body	1	TA To (c) 1090
	450-100	£64.90	STRENGTHENER, rear body	1	TA From (c) 1091 & TB
44	450-105	£38.80	BRACKET, rear door pillar, LH	1	
	450-110	NCA	BRACKET, rear door pillar, RH	1	
46	450-115	£22.50	BRACKET, scuttle side, LH	1	
	450-120	£22.50	BRACKET, scuttle side, RH	1	
48	450-125	NCA	BRACKET, scuttle top, LH	1	
	450-130	NCA	BRACKET, scuttle top, RH	1	
50	456-840	£52.80	SIDE CURTAIN COMPARTMENT	1	front section only

Body Tubs - TA To (c) 1090

450-135	£6,897.00	BODY TUB	1	panelled with doors & scuttle top
450-140	NCA	BODY TUB	1	panelled without doors & scuttle top
450-145	£3,229.00	BODY TUB	1	assembled but un-panelled

Body Tubs - TA From (c) 1091 & TB

450-150	£7,002.00	BODY TUB	1	panelled with doors and scuttle top
450-155	NCA	BODY TUB	1	panelled without doors and scuttle top
450-160	NCA	BODY TUB	1	assembled but un-panelled

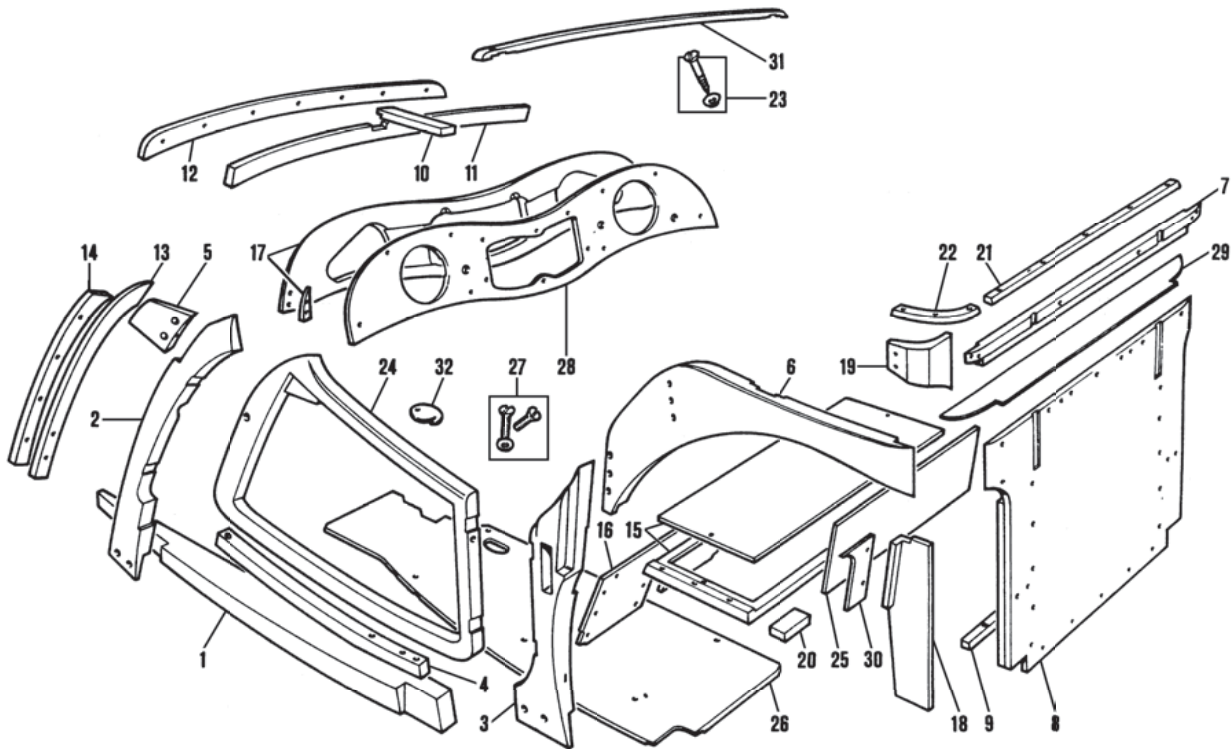

ill.	Part Number	Price £ea.	Description	Req.	Details
Timber Components					
	449-550	£2,310.00	TIMBER SET (Inc: all timbers to build body frame).	1	TA To (c) 1090
	449-555	£2,396.00	TIMBER SET (Inc: all timbers to build body frame).	1	TA From (c) 1091 & TB
1	450-165	£136.00	BOTTOM MAIN RAIL, LH*	1	
	450-170	£136.00	BOTTOM MAIN RAIL, RH*	1	
2	450-175	£144.00	FRONT BODY PILLAR, LH*	1	
	450-180	£144.00	FRONT BODY PILLAR, RH*	1	
3	450-185	£158.00	REAR BODY PILLAR, LH*	1	
	450-190	£158.00	REAR BODY PILLAR, RH*	1	
4	450-195	£79.00	UNDER DOOR RAIL, LH*	1	
	450-200	£79.00	UNDER DOOR RAIL, RH*	1	
5	450-560	£43.00	FRONT BODY PILLAR, 'X Piece**	1	LH
	450-565	£43.00	FRONT BODY PILLAR, 'X Piece**	1	RH
6	450-215	£201.50	REAR WHEEL ARCH, LH*	1	(2 piece)
	450-220	£201.50	REAR WHEEL ARCH, RH*	1	
7	450-225	£97.33	REAR TOP RAIL*	1	
8	450-230	£209.00	REAR CENTRE PANEL*	1	TA To (c) 1090
	450-235	£209.00	REAR CENTRE PANEL*	1	TA From (c) 1091 & TB
9	450-240	£26.70	REAR BOTTOM RAIL*	1	
10	450-245	£43.10	CROSS PIECE, dash to bulkhead*	1	
11	450-250	£39.70	FRONT TOP RAIL, inner*	1	
12	450-255	£70.30	FRONT TOP RAIL, outer*	1	
13	450-260	£34.00	FRONT SIDE RAIL, inner, LH*	1	
	450-265	£34.00	FRONT SIDE RAIL, inner, RH*	1	
14	450-270	£36.00	FRONT SIDE RAIL, outer, LH*	1	
	450-275	£36.00	FRONT SIDE RAIL, outer, RH*	1	
15	450-280	£150.90	PANEL ASSEMBLY, above rear axle*	1	TA To (c) 1090
	450-285	£150.90	PANEL ASSEMBLY, above rear axle*	1	TA From (c) 1091 & TB
16	450-290	£70.30	REAR PROPSHAFT COVER*	1	TA To (c) 1090
	450-635	£70.30	REAR PROPSHAFT COVER*	1	TA From (c) 1091 & TB
17	450-300	£221.70	INNER DASHBOARD PANEL*	1	
18	450-305	£20.25	SIDE OF SIDE SCREEN BOX, LH*	1	
	450-310	£20.25	SIDE OF SIDE SCREEN BOX, RH*	1	
19	450-315	£63.90	REAR ANGLED CORNER PIECE, LH*	1	TA To (c) 1090
	450-320	£63.90	REAR ANGLED CORNER PIECE, LH*	1	TA From (c) 1091 & TB
	450-325	£63.90	REAR ANGLED CORNER PIECE, RH*	1	TA To (c) 1090
	450-330	£63.90	REAR ANGLED CORNER PIECE, RH*	1	TA From (c) 1091 & TB
20	450-335	£24.70	REAR FILLET, LH*	1	TA To (c) 1090
	450-340	£7.22	REAR FILLET, LH*	1	TA From (c) 1091 & TB
	450-345	£24.70	REAR FILLET, RH*	1	TA To (c) 1090
	450-350	£18.20	REAR FILLET, RH*	1	TA From (c) 1091 & TB

*Note: All items are included in the relevant TA-TB timber set.

ill.	Part Number	Price £ea.	Description	Req.	Details
21	450-355	£35.60	RAIL, rear top finisher	1	
22	450-360	£41.00	RAIL, rear corner finisher, LH	1	
	450-365	£41.00	RAIL, rear corner finisher, RH	1	
23	323-858	£9.25	SCREW SET, hood tacking strips	1	
24	450-370	£453.00	DOOR FRAME ASSEMBLY, LH	1	
	450-375	£453.00	DOOR FRAME ASSEMBLY, RH	1	
25	450-380	£36.50	SIDE SCREEN BOX DOOR	1	
	450-390	£119.00	FLOORBOARD, LH	1	TA To (c) 1090
26	450-395	£124.24	FLOORBOARD, LH	1	TA From (c) 1091 & TB
	450-400	£119.00	FLOORBOARD, RH	1	TA To (c) 1090
	450-405	£124.24	FLOORBOARD, RH	1	TA From (c) 1091 & TB
27	323-818	£28.30	SCREW & WASHER SET	1	floorboards, complete
28	456-885	£247.90	DASHBOARD FASCIA, finished veneer	1	alternatives
	456-895	£117.64	DASHBOARD FASCIA, plain	1	
29	450-415	£44.10	SIDE SCREEN BOX TOP SHELF	1	TA To (c) 1090
	450-420	£44.10	SIDE SCREEN BOX TOP SHELF	1	TA From (c) 1091 & TB
30	450-425	£17.40	FINISHER PIECE, side screen box, LH	1	TA To (c) 1090
	450-430	£21.40	FINISHER PIECE, side screen box, LH	1	TA From (c) 1091 & TB
	450-435	£17.40	FINISHER PIECE, side screen box, RH	1	TA To (c) 1090
	450-440	£21.40	FINISHER PIECE, side screen box, RH	1	TA From (c) 1091 & TB
31	453-230	£78.80	TOP RAIL, (wood), over windscreen	1	
32	407-800	£17.35	COVER, master cylinder inspection	1	

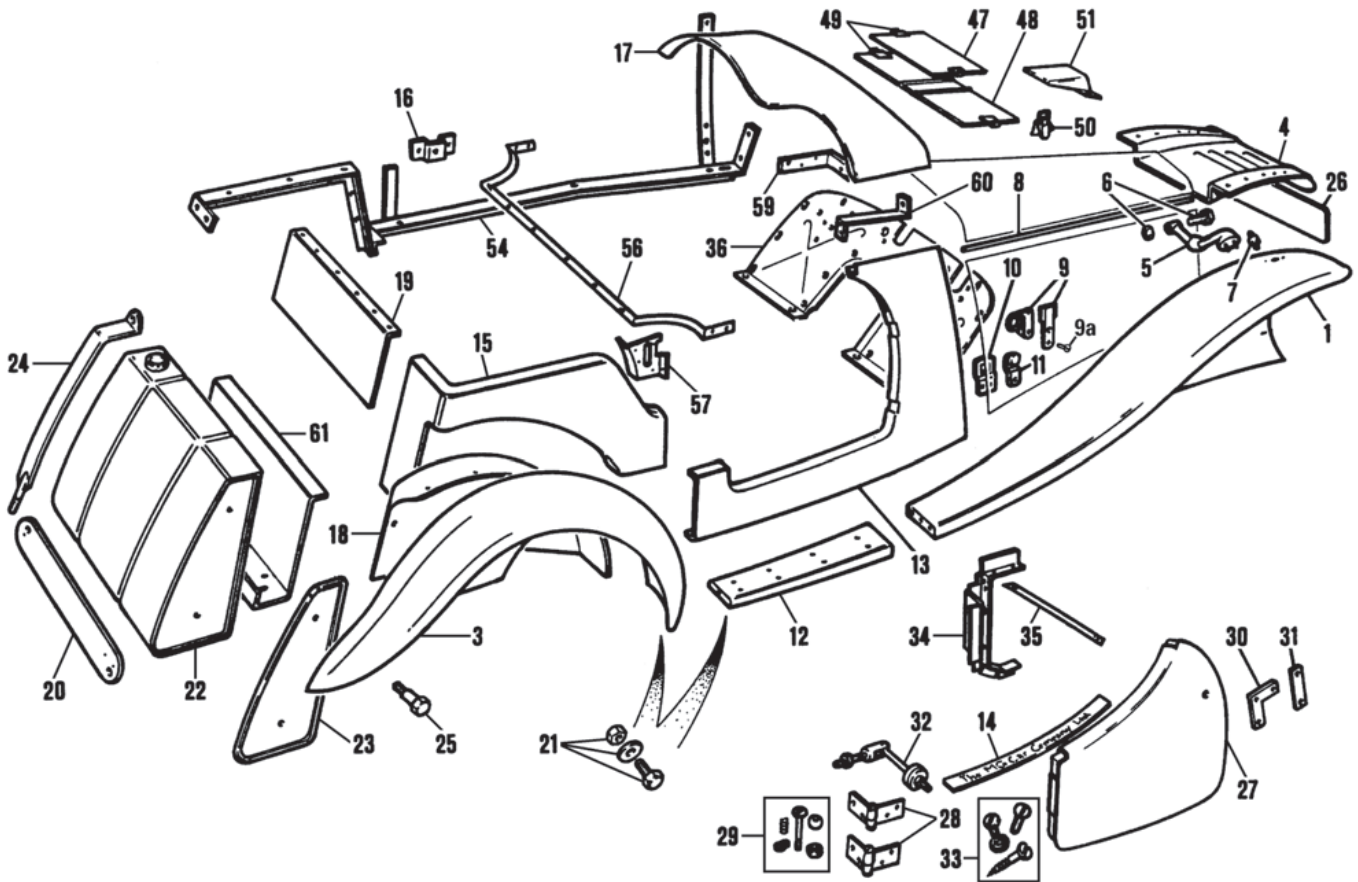

ill.	Part Number	Price £ea.	Description	Req.	Details
Body Panels, TC					
1	456-510	£1,114.00	FRONT WING, RH	1	
	456-500	£1,114.00	FRONT WING, LH	1	
NI	236-210	£137.00	WING COVER SET, pair (These very practical black padded vinyl wing covers are specially tailored to fit your model. Protect that expensive finish from wayward spanners and greasy hands. Both left and right covers are supplied in the set).	2	TA-TC
3	456-610	£784.00	REAR WING, RH	1	
	456-600	£784.00	REAR WING, LH	1	
4	457-100	£248.00	SPLASH APRON, front	1	
5	407-390	£133.00	BRACKET, headlamp, RH	1	
	407-380	£133.00	BRACKET, headlamp, LH	1	
6	321-288	£11.96	BOLT & NUT SET, headlamp bracket	2	1 of each
7	328-175	£4.21	STUD, headlamp bracket	4	
8	453-280	£13.55	ROD, brass, (side panel attaching)	2	
9	406-855	£25.10	BONNET LATCH, RH	2	cadmium plated
	406-860	£25.10	BONNET LATCH, LH	2	
9a	158-018	£6.60	SCREW, bonnet latch	a/r	
10	406-810	£24.00	BRACKET, bonnet latch, on wing	4	
11	406-828	£24.20	BUFFER PLATE SET, bonnet	1	4 buffers & plates
12	457-020	£136.00	RUNNING BOARD, RH	1	
	457-010	£136.00	RUNNING BOARD, LH	1	
13	457-310	£171.00	FRONT QUARTER PANEL, RH	1	
	457-300	£171.00	FRONT QUARTER PANEL, LH	1	
14	451-398	£40.00	THRESHOLD PLATE SET, (pair) (2 plates etched with 'The MG Car Company Ltd').	1	
15	457-410	£193.00	REAR QUARTER PANEL, RH	1	
	457-400	£193.00	REAR QUARTER PANEL, LH	1	
16	450-040	£8.00	REAR SIDE SCREEN BRACKET	2	
17	451-840	£366.00	SCUTTLE TOP	1	
18	457-210	£137.00	WHEEL ARCH, RH	1	
	457-200	£137.00	WHEEL ARCH, LH	1	
19	457-190	£37.00	REAR PANEL	1	between rear quarter panels
20	451-725	£44.00	BLANK PLATE, lamps & number plate	1	
21	321-778	£26.40	BOLT & NUT SET	1	wing & running boards to body
	320-360	£0.80	BOLT, 5/16" BSF x 3/4"	4	
	AJD8105Z	£0.18	NUT, 5/16" BSF	4	
	AJD6308Z	£1.60	BOLT, 3/8" BSF	4	
	AJD8106Z	£0.29	NUT, 3/8" BSF	6	
	AJD8104	£0.34	NUT, 1/4" BSF	6	

ill.	Part Number	Price £ea.	Description	Req.	Details
	320-380	£1.24	BOLT, 5/16" BSF x 1 1/4"	4	
22	456-770	£486.00	FUEL TANK	1	
23	451-638	£172.20	END PANEL SET, fuel tank	1	2 chrome end panels
24	451-600	£27.00	STRAP, fuel tank, primed	2	
	450-055	£43.90	STRAP, fuel tank, chromed	2	optional
25	320-840	£15.55	BOLT, wing to fuel tank	2	
26	451-715	£20.40	NUMBER PLATE, blank, front	1	standard on all TC's
27	446-025	£589.40	DOOR ASSEMBLY, RH	1	panelled
	446-030	£589.40	DOOR ASSEMBLY, LH	1	
	456-835	£263.00	DOOR SKIN, RH	1	
	456-825	£263.00	DOOR SKIN, LH	1	
28	401-858	£298.60	DOOR HINGE SET	1	4 hinges & mounting hardware
29	401-878	£42.00	PIVOT BOLT SET, door hinge	1	complete set with balls
30	401-180	£13.50	MOUNTING PLATE, door lock	2	
31	401-190	£7.70	MOUNTING PLATE, door striker	2	
32	405-500	£16.70	DOOR CHECK	2	
33	323-868	£76.80	SCREW SET	1	for hinges, locks, strikers
34	450-445	£33.70	STRENGTHENER, door hinge, RH	1	
	450-450	£33.70	STRENGTHENER, door hinge, LH	1	
35	450-780	£6.30	DOOR TWIST STRIP	2	
36	450-460	£119.30	BULKHEAD FOOT PLATE	1	
47	454-160	£17.10	LID, battery box	1	
48	451-680	£79.30	LID, tool box	1	
49	401-695	£7.32	CLIP, battery & tool box lids	4	
50	401-685	N/A	LATCH, battery & tool boxes	4	
51	407-120	£39.80	COVER, control cable, (bulkhead)	1	

Body Tub Steelwork					
54	450-465	£340.00	FRAME, body/chassis, LH	1	
	450-470	£340.00	FRAME, body/chassis, RH	1	
56	450-475	N/A	STRENGTHENER, rear body	1	
57	450-480	£36.00	BRACKET, rear door pillar, LH	1	
	450-485	£36.00	BRACKET, rear door pillar, RH	1	
59	450-490	N/A	BRACKET, scuttle side, LH	1	
	450-495	N/A	BRACKET, scuttle side, RH	1	
60	450-500	£26.70	BRACKET, scuttle top, LH	1	
	450-505	N/A	BRACKET, scuttle top, RH	1	
61	456-840	£52.80	SIDE CURTAIN COMPARTMENT	1	front section only

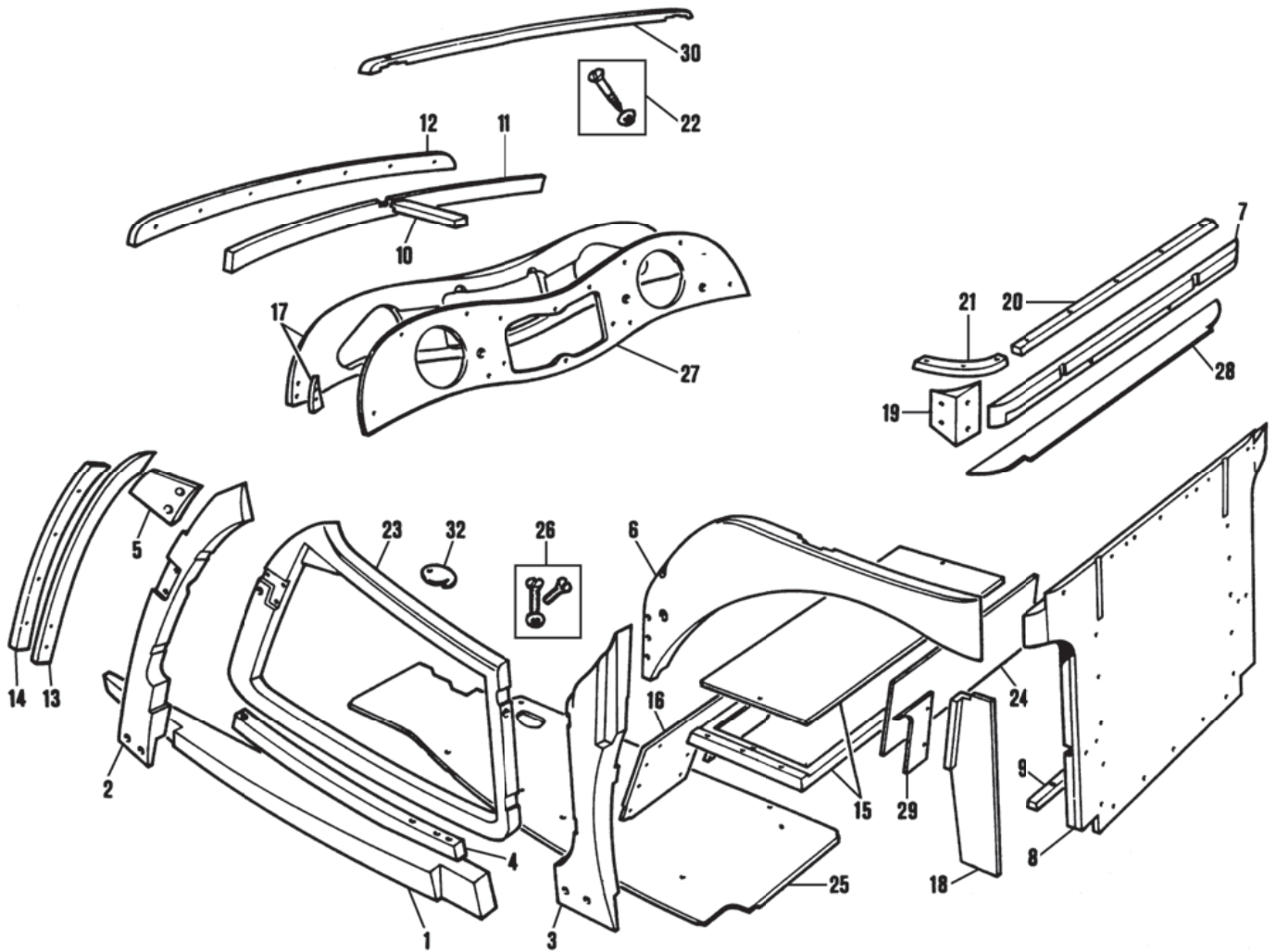

ill.	Part Number	Price £ea.	Description	Req.	Details
Body Tub					
	459-500	£6,406.50	BODY TUB	1	} panelled with doors and scuttle top } panelled without doors and scuttle top } assembled but un-panelled
	450-510	£5,532.00	BODY TUB	1	
	450-515	£4,167.00	BODY TUB	1	

Timber Components

	449-560	£2,213.00	TIMBER SET (Includes all timbers to build body frame).	1	
1	450-520	£113.50	BOTTOM MAIN RAIL, LH*	1	
	450-525	£113.50	BOTTOM MAIN RAIL, RH*	1	
2	450-530	£147.80	FRONT BODY PILLAR, LH*	1	
	450-535	£147.80	FRONT BODY PILLAR, RH*	1	
3	450-540	£175.00	REAR BODY PILLAR, LH*	1	
	450-545	£175.00	REAR BODY PILLAR, RH*	1	
4	450-550	£68.20	UNDER DOOR RAIL, LH*	1	
	450-555	£68.20	UNDER DOOR RAIL, RH*	1	
5	450-560	£43.00	FRONT BODY PILLAR, 'X Piece'*	1	LH
	450-565	£43.00	FRONT BODY PILLAR, 'X Piece'*	1	RH
6	450-570	£198.00	REAR WHEEL ARCH, LH*	1	} (2 piece)
	450-575	£198.00	REAR WHEEL ARCH, RH*	1	
7	450-580	£80.98	REAR TOP RAIL*	1	
8	450-585	£227.00	REAR CENTRE PANEL*	1	
9	450-590	£36.50	REAR BOTTOM RAIL*	1	
10	450-595	£21.30	CROSSPIECE, dash to bulkhead*	1	
11	450-600	£45.20	FRONT TOP RAIL, inner*	1	
12	450-605	£65.00	FRONT TOP RAIL, outer*	1	
13	450-610	£34.30	FRONT SIDE RAIL, inner, LH*	1	
	450-615	£34.30	FRONT SIDE RAIL, inner, RH*	1	
14	450-620	£35.60	FRONT SIDE RAIL, outer, LH*	1	
	450-625	£35.60	FRONT SIDE RAIL, outer, RH*	1	
15	450-630	£195.00	PANEL ASSEMBLY, above rear axle*	1	
16	450-635	£70.30	REAR PROPSHAFT COVER*	1	

ill.	Part Number	Price £ea.	Description	Req.	Details
17	450-640	£220.00	INNER DASHBOARD PANEL*	1	
18	450-645	£23.50	SIDE OF SIDE SCREEN BOX, LH*	1	
	450-650	£23.50	SIDE OF SIDE SCREEN BOX, RH*	1	
19	450-655	£33.30	REAR ANGLED CORNER PIECE, LH*	1	
	450-660	£33.30	REAR ANGLED CORNER PIECE, RH*	1	

*Note: All items are included in the TC timber set.

20	450-665	£45.20	RAIL, rear top finisher	1	
21	450-670	£40.00	RAIL, rear corner finisher, LH	1	
	450-675	£40.00	RAIL, rear corner finisher, RH	1	
22	323-858	£9.25	SCREW SET, hood tacking strips	1	
23	450-680	£447.70	DOOR FRAME ASSEMBLY, LH	1	
	450-685	£447.70	DOOR FRAME ASSEMBLY, RH	1	
24	450-690	£47.40	SIDE SCREEN BOX DOOR	1	
25	450-695	£140.50	FLOORBOARD, LH	1	
	450-700	£140.50	FLOORBOARD, RH	1	
26	323-818	£28.30	SCREW & WASHER SET	1	floorboards, complete
27	233-635	£280.00	DASHBOARD FASCIA, finished veneer	1	} alternatives
	456-890	£120.61	DASHBOARD FASCIA, plain	1	
28	450-705	£52.10	SIDE SCREEN BOX TOP SHELF	1	
29	450-710	£16.00	FINISHER PIECE, side screen box, LH	1	
	450-715	£16.00	FINISHER PIECE, side screen box, RH	1	
30	453-230	£78.80	TOP RAIL, wood, over windscreen	1	
32	407-800	£17.35	COVER, master cylinder inspection	1	

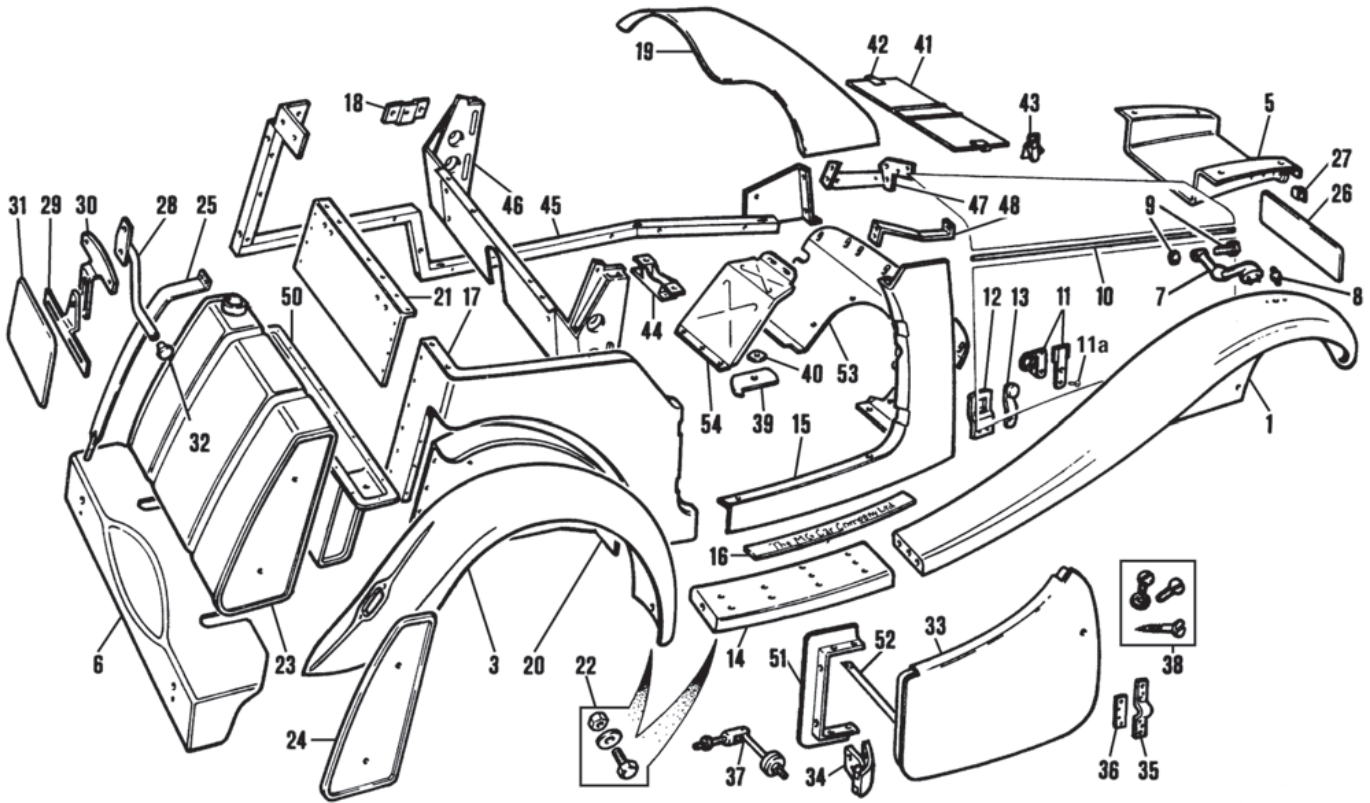

ill.	Part Number	Price £ea.	Description	Req.	Details
Body Panels, TD					
1	456-550	£1,240.00	FRONT WING, RH	1	Girling shock absorbers
	456-530	£1,240.00	FRONT WING, RH	1	Armstrong shock absorbers
	456-540	£1,240.00	FRONT WING, LH	1	Girling shock absorbers
	456-560	£1,240.00	FRONT WING, LH	1	Armstrong shock absorbers
NI	236-220	£136.70	WING COVER SET, pair	2	TD
(These very practical black padded vinyl wing covers are specially tailored to fit your model. Protect that expensive finish from wayward spanners and greasy hands. Both left and right covers are supplied in the set).					
3	456-630	£770.00	REAR WING, RH	1	rect. tail lamp To (c) 21302
	456-650	£923.00	REAR WING, RH	1	round tail lamp From (c) 21303
	456-620	£770.00	REAR WING, LH	1	rect. tail lamp To (c) 21302
	456-640	£923.00	REAR WING, LH	1	round tail lamp From (c) 21303
5	457-110	£180.00	SPLASH APRON, front	1	
6	457-070	£277.40	SPLASH APRON, rear	1	
7	407-420	£134.00	BRACKET, headlamp, RH	1	
	407-410	£134.00	BRACKET, headlamp, LH	1	
8	328-185	£11.00	STUD, headlamp bracket	4	
9	321-288	£11.96	BOLT & NUT SET, headlamp bracket	2	1 of each
10	453-280	£13.55	ROD, brass, (side panel attaching)	2	
11	406-855	£25.10	BONNET LATCH, RH	2	cadmium plated
	406-860	£25.10	BONNET LATCH, LH	2	
11a	158-018	£6.60	SCREW, bonnet latch	a/r	
12	406-800	£19.00	BRACKET, bonnet latch, on wing	4	
13	406-828	£24.20	BUFFER PLATE SET, bonnet	1	4 buffers & plates
14	457-040	£136.00	RUNNING BOARD, RH	1	
	457-030	£136.00	RUNNING BOARD, LH	1	
15	457-330	£231.40	FRONT QUARTER PANEL, RH	1	
	457-320	£231.40	FRONT QUARTER PANEL, LH	1	
16	451-398	£40.00	THRESHOLD PLATE SET, (pair)	1	
(2 plates etched with 'The MG Car Company Ltd').					
17	457-080	£190.00	REAR QUARTER PANEL, RH	1	
	457-090	£190.00	REAR QUARTER PANEL, LH	1	
18	450-720	£8.00	BRACKET, rear side screen, RH	1	
	450-725	£8.00	BRACKET, rear side screen, LH	1	
19	451-850	£502.00	SCUTTLE TOP	1	
20	456-820	£120.00	WHEEL ARCH, RH	1	
	456-830	£120.00	WHEEL ARCH, LH	1	
21	457-130	£37.00	REAR PANEL	1	between rear quarter panels
22	321-758	£40.00	BOLT & NUT SET	1	wing & running boards to body

ill.	Part Number	Price £ea.	Description	Req.	Details
	320-360	£0.80	BOLT, 5/16" BSF x 3/4"	16	
	320-370	£1.33	BOLT, 5/16" BSF x 1"	4	
	AJD8105Z	£0.18	NUT, 5/16" BSF	8	
	AJD6308Z	£1.60	BOLT, 3/8" BSF x 1"	2	
	AJD8106Z	£0.29	NUT, 3/8" BSF	2	
	AJD8104	£0.34	NUT, 1/4" BSF	6	
	320-380	£1.24	BOLT, 5/16" BSF x 1 1/4"	2	
23	456-785	£486.00	FUEL TANK	1	
24	451-648	£178.80	END PANEL SET, fuel tank	1	2 chrome end panels
25	451-610	£40.00	STRAP, fuel tank, primed	2	
	450-730	£46.20	STRAP, fuel tank, chromed	2	optional
26	ALK3268	£5.18	BACKING PLATE, front number plate	1	
27	406-490	£4.94	BRACKET, (for above plate)	2	
28	406-500	£58.20	'S' BRACKET, rear number plate	1	LHD, on spare wheel carrier
	406-520	£58.20	'S' BRACKET, rear number plate	1	RHD, on spare wheel carrier
29	406-510	£54.00	BRACKET, number plate support	1	
30	AAA2179	£12.30	'T' BRACKET	1	number plate lamp support
31	451-275	£33.60	BACKING PLATE	1	rear number plate
32	406-400	£34.70	PLUG, tyre rack, tube end	1	
33	446-035	£738.00	DOOR ASSEMBLY, RH	1	panelled
	446-040	£738.00	DOOR ASSEMBLY, LH	1	
	456-855	£268.00	DOOR SKIN, RH	1	
	456-845	£268.00	DOOR SKIN, LH	1	
34	401-970	£40.00	DOOR HINGE, top, RH	1	brass
	401-960	£40.00	DOOR HINGE, top, LH	1	
	401-990	£40.00	DOOR HINGE, bottom, RH	1	
	401-980	£40.00	DOOR HINGE, bottom, LH	1	
35	401-420	£4.74	MOUNTING PLATE, door striker	2	
36	401-430	£4.74	MOUNTING PLATE, door lock	2	
37	405-500	£16.70	DOOR CHECK	2	
38	323-878	£64.50	SCREW SET	1	for hinges, locks, strikers
39	407-810	£16.20	COVER, transmission dipstick	1	
40	407-425	£19.00	WING NUT, dipstick cover	1	
41	451-680	£79.30	LID, tool box	1	
42	401-695	£7.32	CLIP, tool box lid	2	
43	401-685	NCA	LATCH, tool box	2	
44	411-020	£66.40	BRACKET, gearbox mounting	1	

Body Tub Steelwork

45	450-735	£371.50	FRAME, body/chassis, LH	1
	450-740	£371.50	FRAME, body/chassis, RH	1
46	450-745	£280.00	REAR BODY TIE BAR	1
47	450-750	£94.00	BRACKET, scuttle side, LH	1
	450-755	£94.00	BRACKET, scuttle side, RH	1

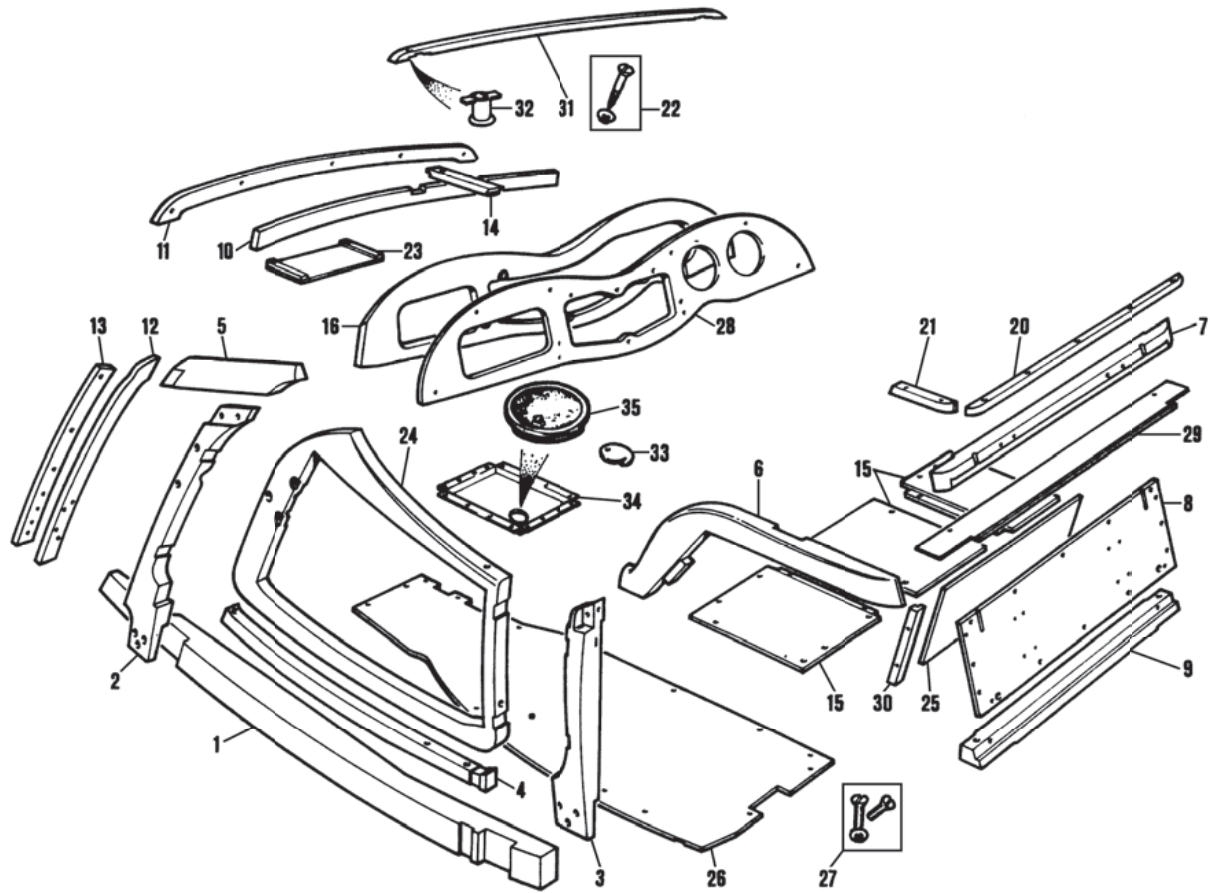

ill.	Part Number	Price £ea.	Description	Req.	Details
48	450-765	£62.00	BRACKET, scuttle top, RH	1	
	450-760	£62.00	BRACKET, scuttle top, LH	1	
50	456-850	£231.80	SIDE SCREEN COMPARTMENT	1	
51	449-040	£23.00	STRENGTHENER, door, LH	1	
	449-045	£23.00	STRENGTHENER, door, RH	1	
52	450-780	£6.30	DOOR TWIST STRIP	2	
53	450-785	£136.70	BULKHEAD FOOT PLATE	1	RHD
	450-785L	£136.70	BULKHEAD FOOT PLATE	1	LHD
54	456-860	£60.00	FOOT REST, on passenger floor	1	

Body Tub

450-790	£8,048.00	BODY TUB, RHD	1	} panelled with doors and scuttle top
450-795	£5,553.00	BODY TUB, RHD	1	
450-800	NCA	BODY TUB, RHD	1	} assembled but un-panelled

Note: All The body tubs listed here are for RHD models. LHD body tubs are also available, please enquire.

Timber Components

	450-805	£1,912.00	TIMBER SET (Includes all timbers to build body frame).	1	
1	450-810	£146.00	BOTTOM MAIN RAIL, LH*	1	
	450-815	£146.00	BOTTOM MAIN RAIL, RH*	1	
2	450-820	£113.30	FRONT BODY PILLAR, LH*	1	
	450-825	£113.30	FRONT BODY PILLAR, RH*	1	
3	450-830	£146.00	REAR BODY PILLAR, LH*	1	
	450-835	£146.00	REAR BODY PILLAR, RH*	1	
4	450-840	£103.10	UNDER DOOR RAIL, LH*	1	
	450-845	£103.10	UNDER DOOR RAIL, RH*	1	
5	450-850	£110.70	FRONT BODY PILLAR, 'X Piece', LH*	1	
	450-855	£110.70	FRONT BODY PILLAR, 'X Piece', RH*	1	
6	450-860	£212.50	REAR WHEEL ARCH, LH*	1	} 2 piece
	450-865	£212.50	REAR WHEEL ARCH, RH*		
7	450-870	£112.78	REAR TOP RAIL*	1	
8	450-875	£121.96	REAR CENTRE PANEL*	1	
9	450-880	£101.88	REAR BOTTOM RAIL*	1	
10	450-885	£59.80	FRONT TOP RAIL, inner*	1	
11	450-890	£83.30	FRONT TOP RAIL, outer*	1	
12	450-895	£72.30	FRONT SIDE RAIL, inner, LH*	1	

ill.	Part Number	Price £ea.	Description	Req.	Details
	450-900	£72.30	FRONT SIDE RAIL, inner, RH*	1	
13	450-905	£65.50	FRONT SIDE RAIL, outer, LH*	1	
	450-910	£65.50	FRONT SIDE RAIL, outer, RH*	1	
14	450-915	£15.95	CROSSPIECE, dash to bulkhead*	1	
15	450-920	£146.60	PANEL ASSEMBLY*	1	above rear axle, set of 3
16	233-580	£170.70	INNER DASHBOARD PANEL, RHD*	1	
	450-925	£144.50	INNER DASHBOARD PANEL, LHD	1	

*Note: All items are included in the TD timber set.

20	450-930	£57.60	RAIL, rear top finisher	1	
21	450-935	£19.55	RAIL, rear corner finisher, LH	1	
	450-940	£19.55	RAIL, rear corner finisher, RH	1	
22	323-858	£9.25	SCREW SET, top finisher rails	1	13 screws & washers
23	407-710	£30.00	BATTERY TRAY	1	
24	450-945	£357.00	DOOR FRAME ASSEMBLY, LH	1	
	450-950	£357.00	DOOR FRAME ASSEMBLY, RH	1	
25	450-955	£41.90	SIDE SCREEN BOX DOOR	1	
26	450-960	£142.40	FLOORBOARD, LH	1	} RHD
	450-965	£142.40	FLOORBOARD, RH	1	
	450-970	£146.00	FLOORBOARD, LH, (no footwell)	1	} LHD
	450-975	£146.00	FLOORBOARD, RH	1	
27	323-828	£47.20	SCREW & WASHER SET	1	floorboards, complete
28	233-530	£544.00	DASHBOARD, finished walnut veneer	1	} RHD
	233-570	£135.00	DASHBOARD, plywood	1	
	233-645	£515.00	DASHBOARD, finished walnut veneer	1	} LHD
	233-510	£139.00	DASHBOARD, plywood	1	
29	450-985	£57.60	SIDE SCREEN BOX TOP SHELF	1	
30	450-990	£30.30	FINISHER PIECE, side screen box, LH	1	
	450-995	£30.30	FINISHER PIECE, side screen box, RH	1	
31	453-240	£78.80	TOP RAIL, (wood), over windscreen	1	
32	AFH2635	£4.70	SOCKET, (brass), top rail	2	
33	407-800	£17.35	COVER, master cylinder inspection	1	LHD To (c) 4236; all RHD
34	456-870	£82.85	FOOTWELL, (metal)	1	LHD From (c) 4237
35	ACA5300	£2.92	PLUG, master cylinder inspection	1	LHD

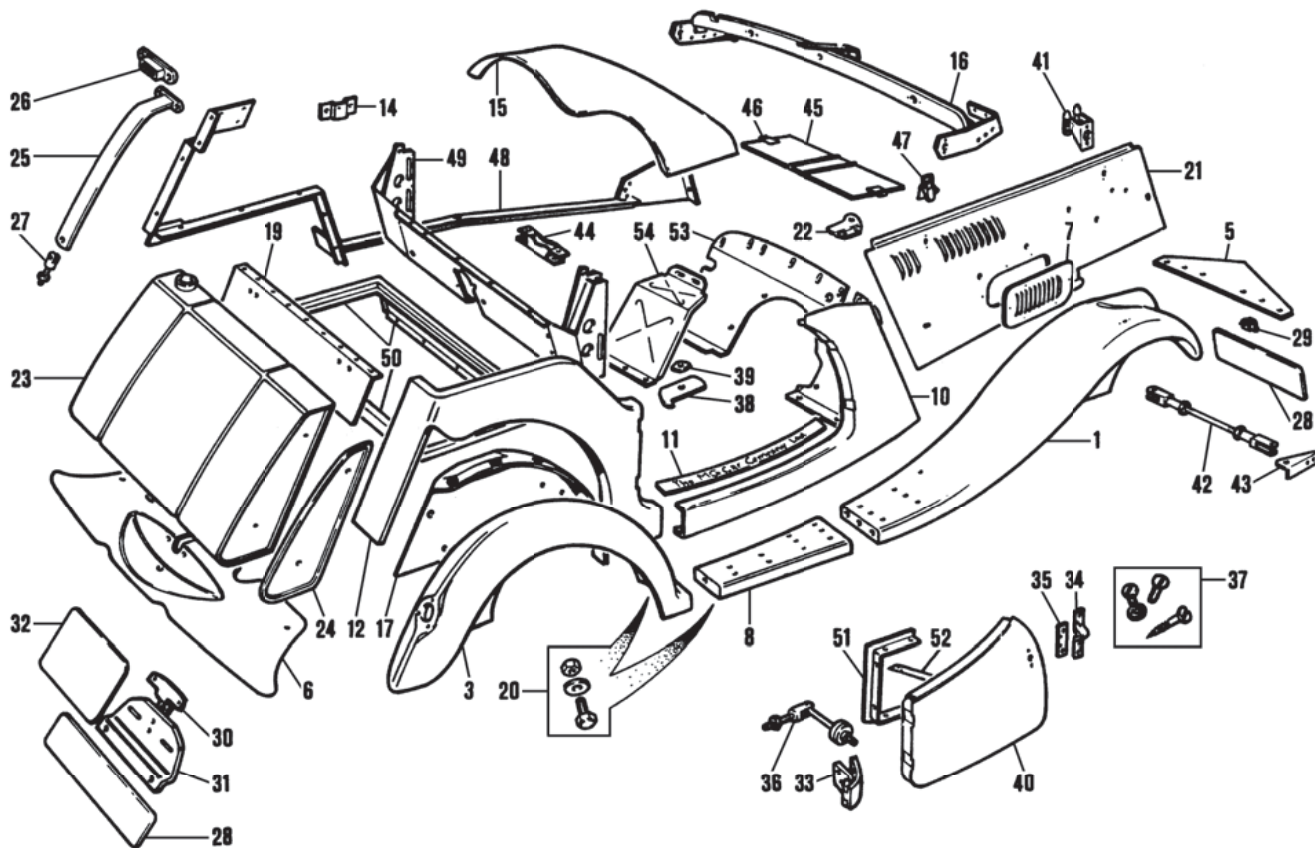

ill.	Part Number	Price £ea.	Description	Req.	Details
Body Panels, TF					
1	456-490	£1,255.00	FRONT WING, RH	1	
	456-480	£1,255.00	FRONT WING, LH	1	
NI	236-230	£137.00	WING COVER SET, pair	2	TF
(These very practical black padded vinyl wing covers are specially tailored to fit your model. Protect that expensive finish from wayward spanners and greasy hands. Both left and right covers are supplied in the set).					
3	456-670	£770.00	REAR WING, RH	1	
	456-660	£770.00	REAR WING, LH	1	
5	451-090	£40.80	SPLASH APRON, front	1	
6	456-520	£321.00	SPLASH APRON, rear	1	
7	451-740	£56.80	LOUVRE PANEL, bonnet side	2	
8	457-060	£136.00	RUNNING BOARD, RH	1	
	457-050	£136.00	RUNNING BOARD, LH	1	
10	456-570	£226.50	FRONT QUARTER PANEL, RH	1	
	456-580	£226.50	FRONT QUARTER PANEL, LH	1	
11	451-398	£40.00	THRESHOLD PLATE SET, (pair)	1	
(2 plates etched with 'The MG Car Company Ltd').					
12	456-680	£297.50	REAR QUARTER PANEL, RH	1	
	456-690	£297.50	REAR QUARTER PANEL, LH	1	
14	450-720	£8.00	BRACKET, rear side screen, RH	1	
	450-725	£8.00	BRACKET, rear side screen, LH	1	
15	451-860	£496.00	SCUTTLE TOP	1	
16	456-865	NCA	SCUTTLE FRAME	1	
17	457-220	£137.00	WHEEL ARCH, RH	1	
	457-230	£137.00	WHEEL ARCH, LH	1	
19	457-140	£37.00	REAR PANEL, between rear quarter panels	1	
20	321-768	£72.40	BOLT & NUT SET	1	wing & running boards to body
	320-360	£0.80	BOLT, 5/16" BSF x 3/4"	16	
	320-370	£1.33	BOLT, 5/16" BSF x 1"	4	
	AJD8105Z	£0.18	NUT, 5/16" BSF	8	
	AJD6308Z	£1.60	BOLT, 3/8" BSF x 1"	12	
	AJD8106Z	£0.29	NUT, 3/8" BSF	2	
	320-380	£1.24	BOLT, 5/16" BSF x 1 1/4"	16	
	AJD8104	£0.34	NUT, 1/4" BSF	14	
	BTB610	£1.85	BOLT	6	
21	457-915	£278.50	SIDE PANEL, bonnet, LH	1	
	457-925	£278.50	SIDE PANEL, bonnet, RH	1	
22	406-935	£21.00	CORNER BRACKET, LH	1	bonnet to bulkhead
	406-945	£21.00	CORNER BRACKET, RH	1	
23	456-795	£486.00	FUEL TANK	1	
24	451-658	£172.20	END PANEL SET, fuel tank	1	2 chrome end panels

ill.	Part Number	Price £ea.	Description	Req.	Details
25	451-620	£29.00	STRAP, fuel tank, primed	2	
	449-000	£41.00	STRAP, fuel tank, chromed	2	optional
26	407-110	£22.95	TOP BRACKET	2	fuel tank strap, chromed
27	449-005	£42.00	BOTTOM BRACKET, fuel tank strap	2	
28	ALK3268	£5.18	BLANK NUMBER PLATE, front & rear	2	UK models
29	406-490	£4.94	BRACKET, for above plate	2	
30	AAA2179	£12.30	'T' BRACKET, number lamp support	1	
31	AHH5151	£15.00	BRACKET, number plate assembly	1	
32	AHA5211	£7.20	BACKING PLATE, number plate, rear	1	US models
33	401-970	£40.00	DOOR HINGE, top, RH	1	brass
	401-960	£40.00	DOOR HINGE, top, LH	1	
	401-990	£40.00	DOOR HINGE, bottom, RH	1	
	401-980	£40.00	DOOR HINGE, bottom, LH	1	
34	401-420	£4.74	MOUNTING PLATE, door striker	2	
35	401-430	£4.74	MOUNTING PLATE, door lock	2	
36	405-500	£16.70	DOOR CHECK	2	
37	323-878	£64.50	SCREW SET	1	for hinges, locks, strikers
38	407-810	£16.20	COVER, transmission dipstick	1	
39	407-425	£19.00	WING NUT, dipstick cover	1	
40	446-045	£738.00	DOOR ASSEMBLY, RH	1	pannelled
	446-050	£738.00	DOOR ASSEMBLY, LH	1	
	449-010	£338.20	DOOR SKIN, LH	1	
	449-015	£339.00	DOOR SKIN, RH	1	
41	457-895	NCA	BONNET LATCH, RH	2	
	457-905	NCA	BONNET LATCH, LH	2	
42	451-825	£131.50	TIE BAR, front wing	1	
43	451-885	£15.00	BRACKET, tie bar, RH	1	
	451-880	£15.00	BRACKET, tie bar, LH	1	
44	411-020	£66.40	BRACKET, gearbox mounting	1	
45	451-680	£79.30	LID, tool box	1	
46	401-695	£7.32	CLIP, tool box lid	2	
47	401-685	NCA	LATCH, tool box	2	

Body Tub Steelwork

48	449-020	£345.00	FRAME, body/chassis, LH	1	
	449-025	£345.00	FRAME, body/chassis, RH	1	
49	449-030	£302.40	REAR BODY TIE BAR	1	
50	449-035	£84.46	SIDE SCREEN COMPARTMENT	1	4 piece
51	449-045	£23.00	STRENGTHENER, door, RH	1	
	449-040	£23.00	STRENGTHENER, door, LH	1	
52	450-780	£6.30	DOOR TWIST STRIP	2	
53	450-785	£136.70	BULKHEAD FOOT PLATE	1	RHD
54	456-860	£60.00	FOOT REST, on passenger floor	1	

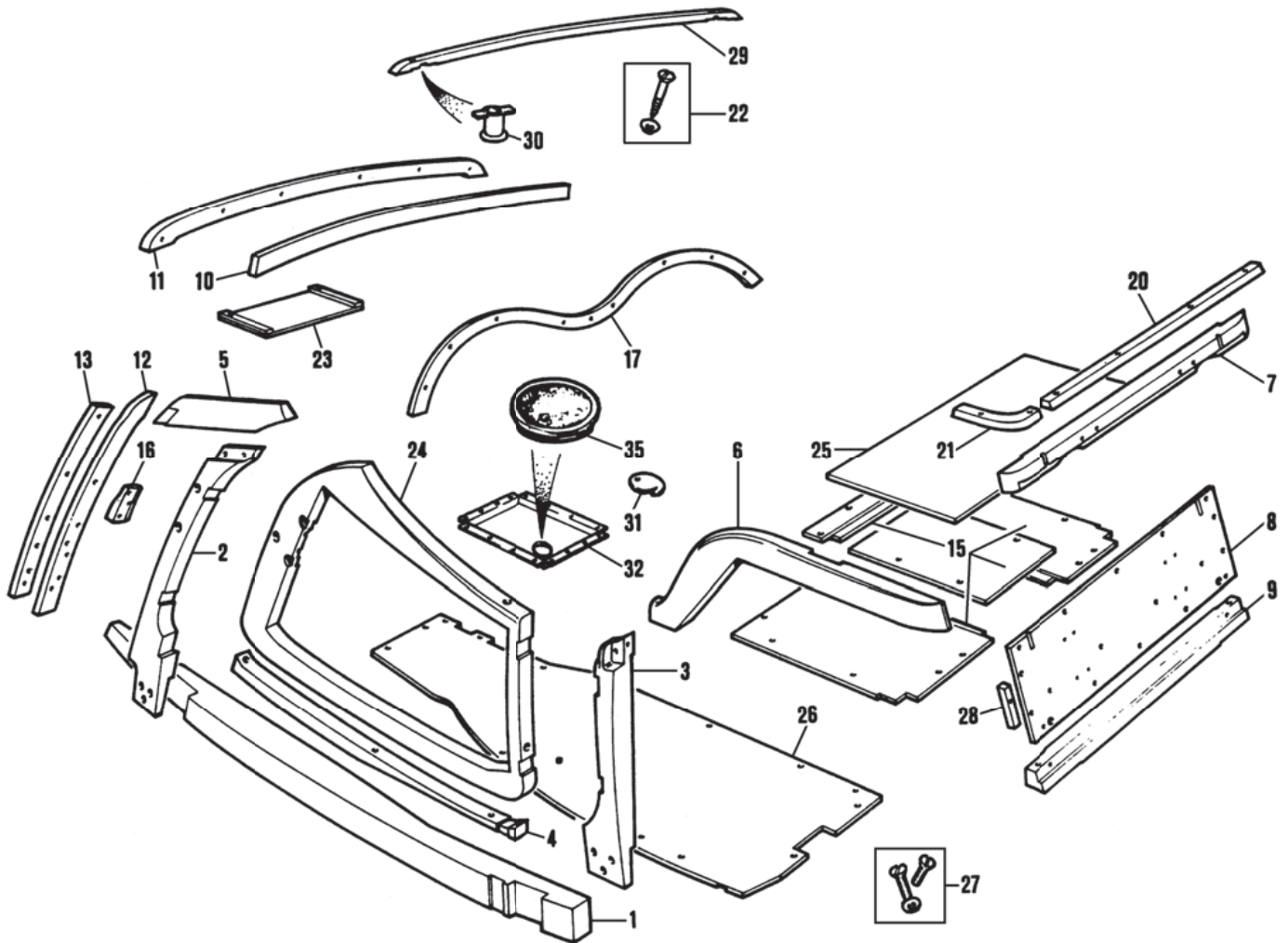

ill.	Part Number	Price £ea.	Description	Req.	Details
Body Tub					
	459-520	£8,817.00	BODY TUB, RHD	1	panelled with doors & scuttle top
	449-050	£5,112.00	BODY TUB, RHD	1	panelled without doors & scuttle top
	449-055	£3,222.00	BODY TUB, RHD	1	assembled but un-panelled

Timber Components

	449-565	£1,718.00	TIMBER SET (Includes all timbers to build body frame).	1	
1	449-060	£149.00	BOTTOM MAIN RAIL, LH*	1	
	449-065	£149.00	BOTTOM MAIN RAIL, RH*	1	
2	449-070	£150.00	FRONT BODY PILLAR, LH*	1	
	449-075	£150.00	FRONT BODY PILLAR, RH*	1	
3	449-080	£176.00	REAR BODY PILLAR, LH*	1	
	449-085	£176.00	REAR BODY PILLAR, RH*	1	
4	449-090	£92.00	UNDER DOOR RAIL, LH*	1	
	449-095	£92.00	UNDER DOOR RAIL, RH*	1	
5	449-100	£64.90	FRONT BODY PILLAR, 'X Piece'*	1	LH
	449-105	£64.90	FRONT BODY PILLAR, 'X Piece'*	1	RH
6	449-110	£161.60	REAR WHEEL ARCH, LH*	1	
	449-115	£161.60	REAR WHEEL ARCH, RH*	1	
7	449-120	£88.57	REAR TOP RAIL*	1	
8	449-125	£67.10	REAR CENTRE PANEL*	1	
9	449-130	£90.79	REAR BOTTOM RAIL*	1	
10	449-135	£57.50	FRONT TOP RAIL, inner*	1	
11	449-140	£70.30	FRONT TOP RAIL, outer*	1	
12	449-145	£72.30	FRONT SIDE RAIL, inner, LH*	1	
	449-150	£72.30	FRONT SIDE RAIL, inner, RH*	1	
13	449-155	£70.30	FRONT SIDE RAIL, outer, LH*	1	

ill.	Part Number	Price £ea.	Description	Req.	Details
	449-160	£70.30	FRONT SIDE RAIL, outer, RH	1	
	15	£182.00	PANEL ASSEMBLY*	1	above rear axle
	16	£16.40	WEDGE, chassis frame to body*	1	LH
	449-175	£16.60	WEDGE, chassis frame to body*	1	RH
*Note: All items are included in the TF timber set.					
	17	£71.70	RAIL, dashboard finisher	1	
	20	£44.15	RAIL, rear top finisher	1	
	21	£40.70	RAIL, rear corner finisher	1	LH
	449-195	£40.70	RAIL, rear corner finisher	1	RH
	22	£9.25	SCREW SET, top finisher rail	1	13 screws & washers
	23	£30.00	BATTERY TRAY	1	
	24	£408.00	DOOR FRAME ASSEMBLY, LH	1	
	449-205	£408.00	DOOR FRAME ASSEMBLY, RH	1	
	25	£55.30	SIDE SCREEN BOX DOOR	1	
	26	£139.30	FLOORBOARD, LH	1	RHD
	449-220	£139.30	FLOORBOARD, RH	1	
	449-225	£139.30	FLOORBOARD, LH, (no footwell)	1	LHD
	449-230	£139.30	FLOORBOARD, RH	1	
	27	£47.20	SCREW & WASHER SET	1	floorboards, complete
	28	£6.20	WEDGE, rear body panel trim	2	
	29	£78.80	TOP RAIL (wood), over windscreen	1	
	30	£4.70	SOCKET, (brass) top rail	2	
	31	£17.35	COVER, master cylinder inspection	1	RHD
	32	£82.85	FOOTWELL, (metal)	1	LHD
	35	£2.92	PLUG, master cylinder inspection	1	

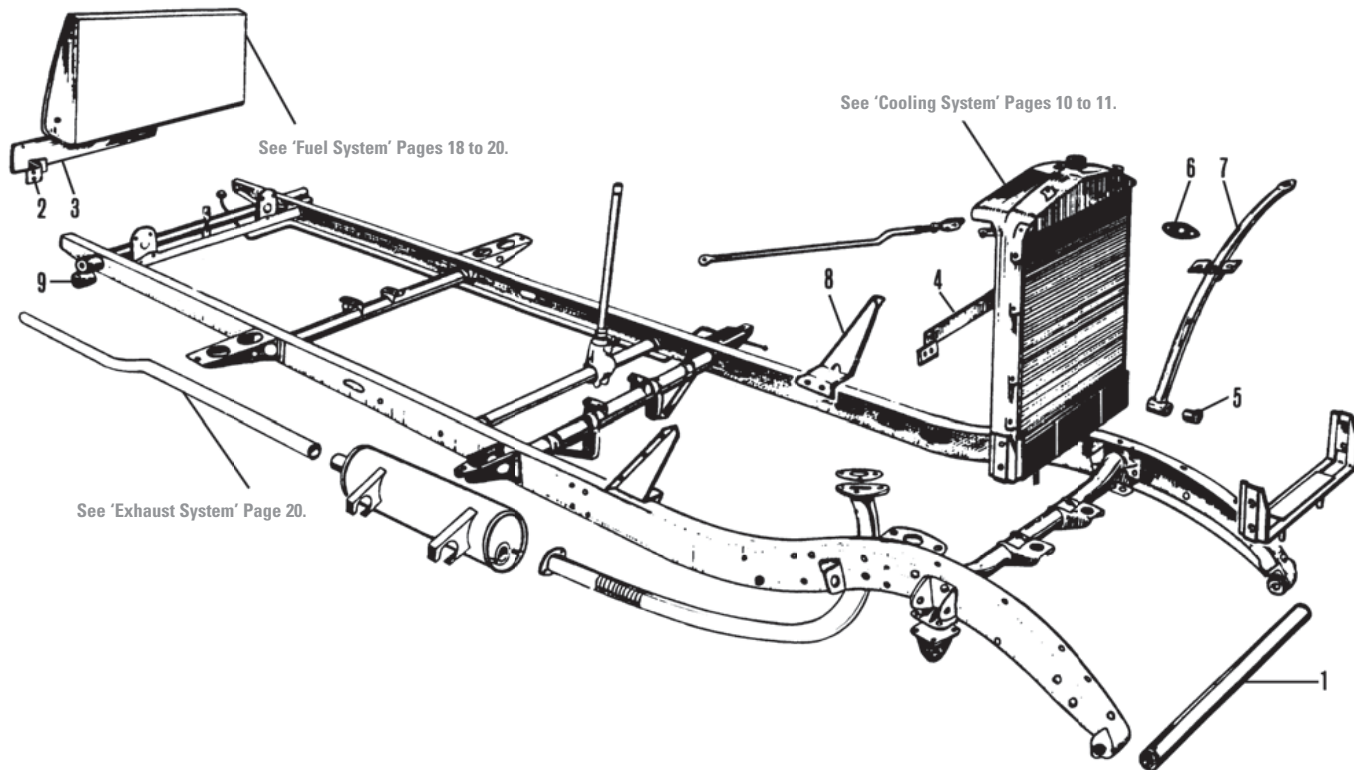

See 'Cooling System' Pages 10 to 11.

See 'Exhaust System' Page 20.

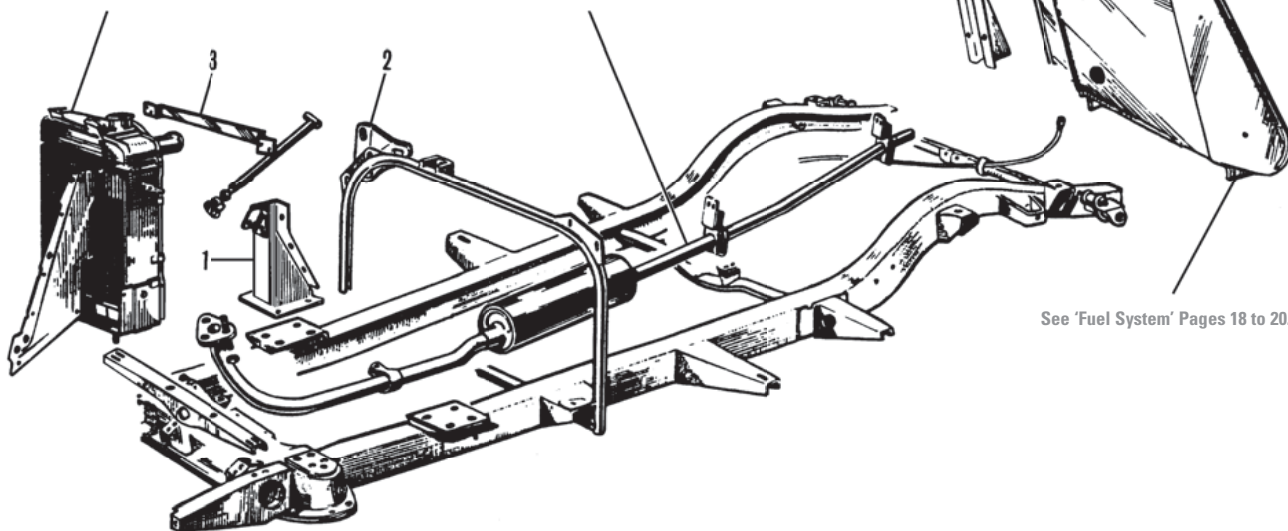

See 'Fuel System' Pages 18 to 20.

ill.	Part Number	Price £ea.	Description	Req.	Details
Chassis Frame & Fittings, TA-TB & TC					
1	451-190	£77.60	FRONT CHASSIS CROSS MEMBER	1	
2	406-330	£29.50	MOUNTING BRACKET, number plate	2	
3	450-045	£37.80	BLANK PLATE, round rear lamps	1	TA To (c) 1789
	451-725	£44.00	BLANK PLATE, 'D' rear lamps	1	TA From (c) 1790, TB & TC
4	451-100	£60.10	TIE BRACKET, headlamp mounting	1	
5	1B8347	£1.34	BUSH, wing brace	4	
6	280-090	£1.55	PAD, wing to brace	2	
7	451-830	£58.00	FRONT WING BRACE, LH	1	
	451-835	£58.00	FRONT WING BRACE, RH	1	
8	452-700	£181.00	SUPPORT BRACKET, bulkhead, LH	1	
	452-710	£181.00	SUPPORT BRACKET, bulkhead, RH	1	
9	PW072	£82.20	TRUNNION BUSH REPAIR, RH	1	
	PW072A	£82.20	TRUNNION BUSH REPAIR, LH (Also known as sliding bush).	1	TA & TB

ill.	Part Number	Price £ea.	Description	Req.	Details
Chassis Frame & Fittings, TD & TF					
1	449-570	NCA	BULKHEAD FOOT, RH	1	
	449-575	NCA	BULKHEAD FOOT, LH	1	
2	449-580	£28.15	BRACKET, roll bar to body, RH	1	
	449-585	£28.15	BRACKET, roll bar to body, LH	1	
3	451-100	£60.10	TIE BRACKET, headlamp mounting	1	TD

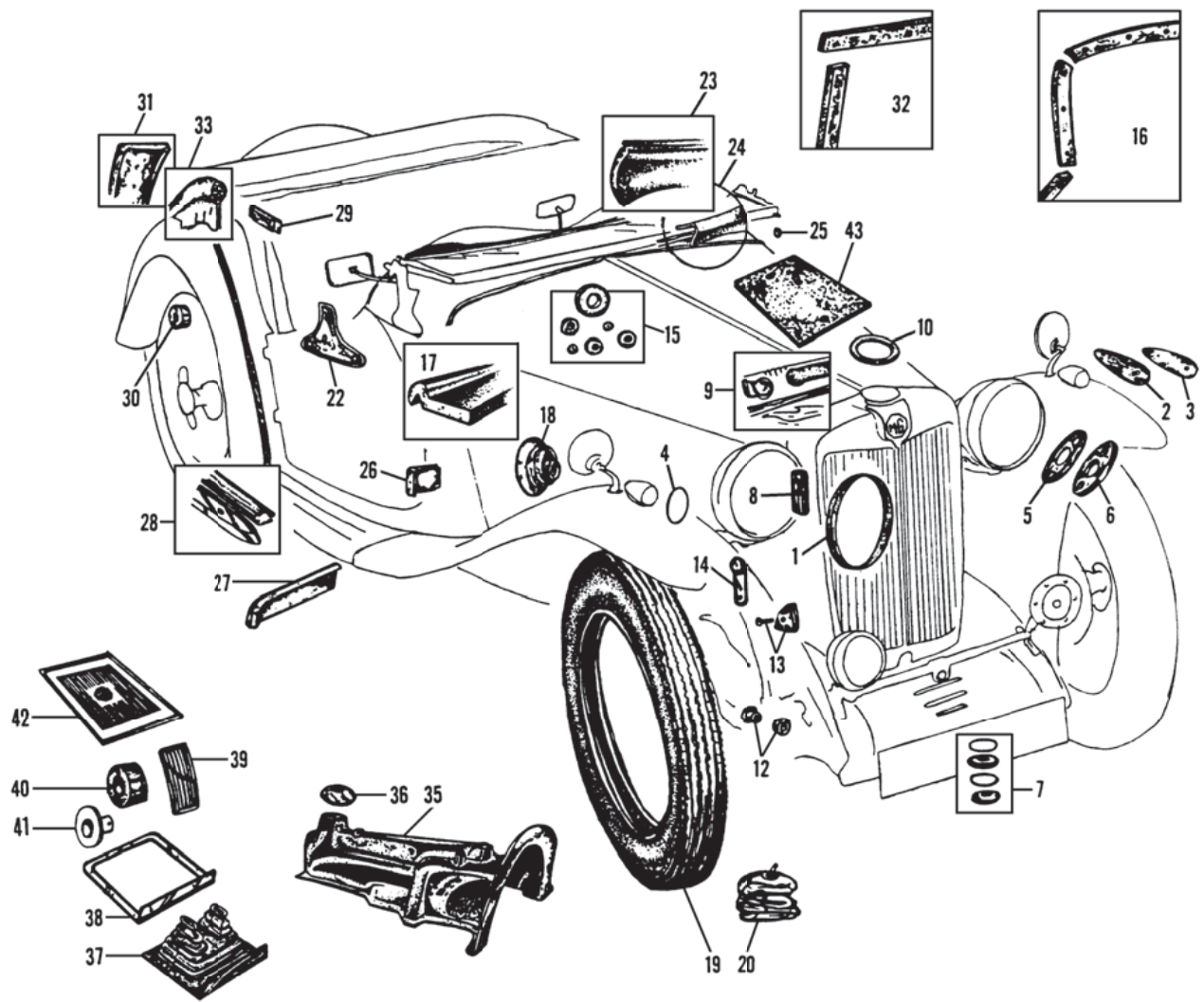

Part Number	Price £ea.	Description	Req.	Details
1	281-098	£16.65 SEAL SET, headlamp	1	2 seals
2	281-078	£4.07 PAD SET, wing to brace	1	2 pads
3	281-068	£4.37 PAD SET, parking lamp	1	2 pads
4	281-088	£2.15 RING SET, parking lamp lens	1	2 rings
5	281-048	£3.77 PAD SET, headlamp bracket to wing	1	2 pads
6	281-058	£4.07 PAD SET, wing to bonnet	1	2 pads
7	281-648	£12.05 MOUNTING SET, radiator, 8 pieces	1	includes steel rings
8	281-018	£3.77 FERRULE SET, radiator shell	1	2 ferrules
9	408-255	£17.60 STRIP, radiator shell lacing	1	canvas
10	280-020	£1.50 SEAL, radiator cap	1	
11	1B8347	£1.34 BUSH, wing brace	4	
12	281-118	£6.30 CORNER SET, bonnet, 8 pieces	1	includes rivets
13	406-828	£24.20 BUFFER PLATE SET, bonnet	1	4 buffers & plates
14	281-128	£7.96 GROMMET SET, bulkhead	1	6 grommets
15	280-918	£42.20 COWL SET, bulkhead to body	1	5 pieces
16	280-250	£18.40 STRIP, cowl to bonnet	1	
17	280-380	£9.00 EXCLUDER	1	bulkhead to steering column
18	454-700	£192.50 TYRE, 4.50 x 19", Dunlop	5	original tyres
19	454-410	£33.60 INNER TUBE, 4.50 x 19"	5	
20	281-178	£5.15 PAD SET, windscreen bracket to cowl	1	2 pads
21	280-290	£11.50 STRIP, windscreen frame to cowl	1	under windscreen
22	280-300	£11.60 STRIP, windscreen glass to frame	1	
23	280-270	£0.82 GROMMET, windscreen wiper wire	1	in cowl

Part Number	Price £ea.	Description	Req.	Details
24	281-198	£4.74 BUFFER SET, door to body	1	4 buffers
25	281-218	£6.20 PAD SET, wing to running board	1	2 pads
26	281-008	£59.70 STRIP SET, running board	1	TA & TB
		(6 pieces aluminium & rubber).		
27	281-238	£60.10 STRIP SET, running board	1	TC
		(4 pieces aluminium & rubber).		
28	281-208	£4.52 BUFFER SET, hood bow	1	2 buffers
29	281-308	£1.40 BUSH SET, fuel tank to wing	1	2 bushes
30	281-298	£15.25 STRIP SET, fuel tank strap	1	2 strips
31	280-928	£63.10 TANK SET, tank to body & chassis	1	5 pieces
32	249-120	£52.50 BLACK PIPING SET, 9 yards	1	exterior set
33	249-220	£52.50 RED PIPING SET, 9 yards	1	
	249-320	£52.50 GREEN PIPING SET, 9 yards	1	
	249-370	NCA CREAM PIPING SET, 9 yards	1	
	249-250	£52.50 BISCUIT PIPING SET, 9 yards	1	
34	281-288	£172.80 GEARBOX COVER	1	
35	280-470	£4.48 SNUG, gearshift lever	1	
36	280-420	£13.60 FUME EXCLUDER	1	brake & clutch pedal
37	406-700	£7.70 RETAINING PLATE, fume excluder	1	steel
38	280-440	£2.62 PAD, brake & clutch pedal	2	
39	408-680	£15.70 ROLLER, accelerator pedal	1	hard plastic
40	408-685	£16.15 BUSH, for roller	1	steel
41	280-995	£19.00 HEEL MAT, on driver's floor	1	as original
42	280-700	NCA PAD, under battery	1	TC

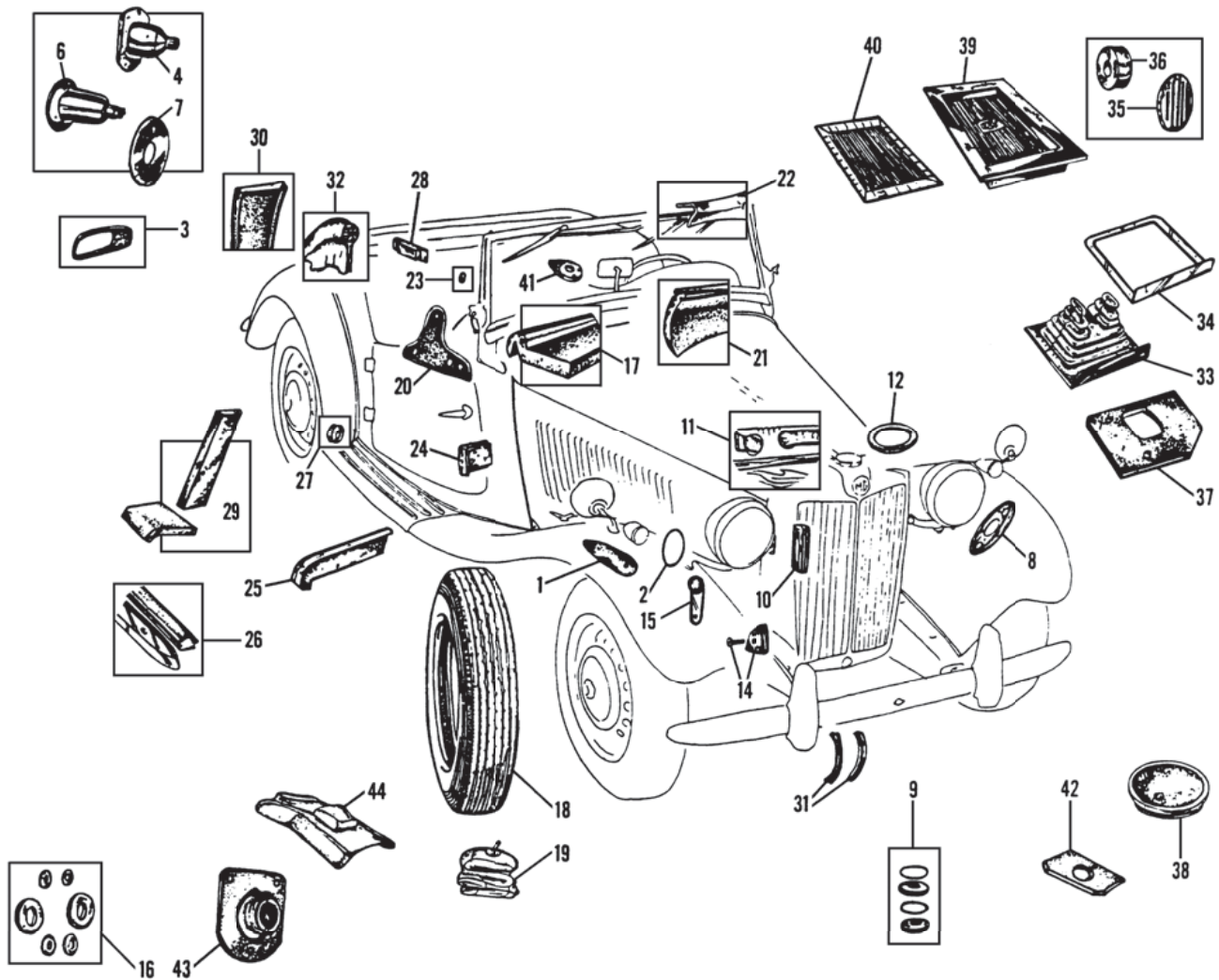

ill.	Part Number	Price £ea.	Description	Req.	Details
Rubber Fittings, TD					
1	281-068	£4.37	PAD SET, parking lamp	1	2 pads
2	281-088	£2.15	RING SET, parking lamp	1	2 rings
3	57H5368	£3.22	SEAL, number plate lamp	1	
4	280-510	£9.50	BODY, rectangular tail lamp	2	To (c) 21302
6	37H5481	£2.60	BODY, round tail lamp	2	From (c) 21303
7	281-338	£5.20	PAD SET, round lamp to wing	1	
8	281-048	£3.77	PAD SET, headlamp bracket to wing	1	2 pads
9	281-648	£12.05	MOUNTING SET, radiator, 8 pieces	1	includes steel rings
10	281-018	£3.77	FERRULE SET, radiator shell	1	2 ferrules
11	408-255	£17.60	STRIP, radiator shell lacing	1	
12	280-020	£1.50	SEAL, radiator cap	1	
14	281-118	£6.30	CORNER SET, bonnet, 8 pieces	1	includes rivets
15	406-828	£24.20	BUFFER PLATE SET, bonnet	1	4 buffers & plates
16	281-138	£13.00	GROMMET SET, bulkhead	1	6 grommets
	600395	£1.00	GROMMET, temperature gauge	1	
17	280-250	£18.40	STRIP, cowl to bonnet	1	
18	454-710	NCA	TYRE, 5.50 x 15", Dunlop	5	similar to
19	454-420	£31.50	INNER TUBE, 5.50 x 15", Dunlop	5	original tyres
20	281-188	£5.35	PAD SET, windscreen bracket to cowl	1	2 pads
21	280-290	£11.50	STRIP, windscreen frame to cowl	1	under windscreen
22	280-300	£11.60	STRIP, windscreen glass to frame	1	
23	280-270	£0.82	GROMMET, windscreen wiper wire	1	in cowl
24	281-198	£4.74	BUFFER SET, door to body	1	4 buffers

ill.	Part Number	Price £ea.	Description	Req.	Details
25	281-218	£6.20	PAD SET, wing to running board	1	2 pads
26	281-248	£78.00	STRIP SET, running board	1	6 pieces, aluminium & rubber
27	281-258	£2.35	BUSH SET, wing to running board	1	2 bushes
28	281-208	£4.52	BUFFER SET, hood bow	1	2 buffers
29	281-798	£16.80	PAD SET, fuel tank to chassis	1	4 pads
30	281-298	£15.25	STRIP SET, fuel tank strap	1	2 strips
31	37H9871M	£1.20	PACKING SET, override to bumper	1	8 strips
32	249-120	£52.50	BLACK PIPING SET, 9 yards	1	exterior set
	249-220	£52.50	RED PIPING SET, 9 yards	1	
	249-320	£52.50	GREEN PIPING SET, 9 yards	1	
	249-370	NCA	CREAM PIPING SET, 9 yards	1	
	249-250	£52.50	BEIGE PIPING SET, 9 yards	1	
33	280-420	£13.60	FUME EXCLUDER	1	brake & clutch pedal
34	406-700	£7.70	RETAINING PLATE, pedal excluder	1	steel
35	ACA5359	£1.80	PAD, brake & clutch pedal	2	
36	408-690	£13.15	ROLLER, accelerator pedal	1	hard plastic
37	280-430	£5.90	PAD, floorboard to pedal box	1	
38	ACA5300	£2.92	PLUG, master cylinder inspection	1	LHD From (c) 4237, all RHD
39	280-400	£21.00	FOOTWELL, driver's floor	1	
40	CRM2001X	£12.60	HEEL MAT, driver's floor	1	LHD To (c) 4236, all RHD
41	280-260	£1.85	PAD, interior mirror	1	
42	282-670	£11.50	PAD, under floor & around roll bar	2	
43	454-040	£38.80	FUME EXCLUDER	1	steering column, leather
44	282-680	£36.50	RUBBER SNUG	1	gearshift remote control

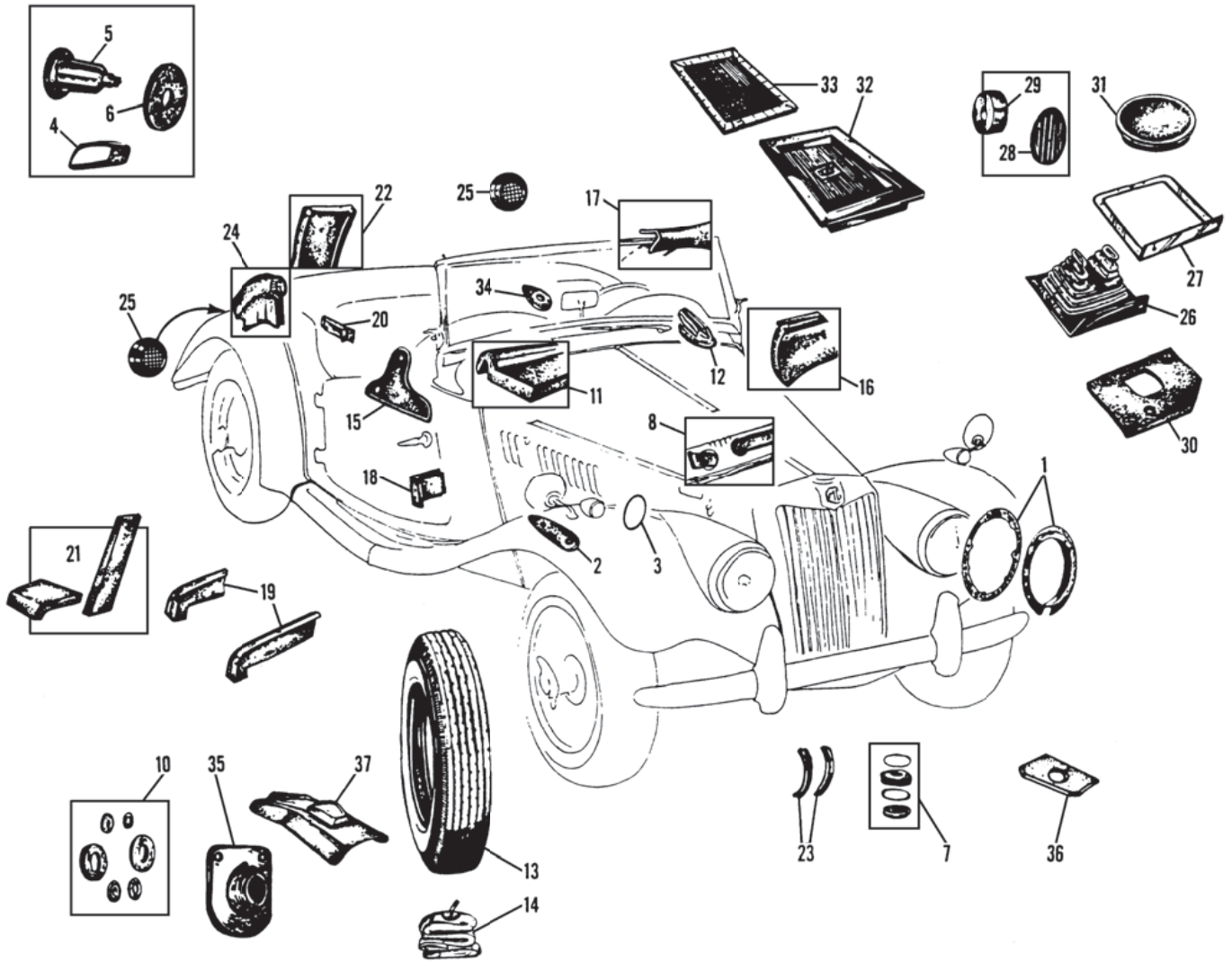

ill.	Part Number	Price £ea.	Description	Req.	Details
Rubber Fittings, TF					
1	281-108	£11.70	SEAL SET, headlamp	1	4 seals
2	281-068	£4.37	PAD SET, parking lamp	1	2 pads
3	281-088	£2.15	RING SET, parking lamp	1	2 rings
4	57H5368	£3.22	SEAL, number plate lamp	1	
5	37H5481	£2.60	BODY, tail lamp	2	
6	281-338	£5.20	PAD SET, tail lamp to wing	1	2 pads
7	281-648	£12.05	MOUNTING SET, radiator, 8 pieces	1	includes steel rings
8	280-010	£4.37	STRIP, radiator shell lacing	1	
10	281-138	£13.00	GROMMET SET, bulkhead	1	6 grommets
11	280-250	£18.40	STRIP, cowl to bonnet	1	
12	281-168	£29.00	GROMMET SET, wiper shaft	1	2 grommets
	280-280	£15.00	GROMMET, wiper shaft	2	single grommet
	600395	£1.00	GROMMET, temperature gauge	1	
13	454-710	NCA	TYRE, 5.50 x 15", Dunlop	5	similar to
14	454-420	£31.50	INNER TUBE, 5.50 x 15", Dunlop	5	original tyre
15	281-188	£5.35	PAD SET, windscreen bracket to cowl	1	2 pads
16	280-290	£11.50	STRIP, windscreen frame to cowl	1	under windscreen
17	280-300	£11.60	STRIP, windscreen glass to frame	1	
18	281-198	£4.74	BUFFER SET, door to body	1	4 buffers
19	281-218	£6.20	PAD SET, wing to running board	2	2 pads
20	281-208	£4.52	BUFFER SET, rear side-screen to hood	1	2 buffers
21	281-798	£16.80	PAD SET, fuel tank to chassis	1	4 pads
22	281-298	£15.25	STRIP SET, fuel tank strap	1	2 strips

ill.	Part Number	Price £ea.	Description	Req.	Details
23	37H9871M	£1.20	PACKING SET, overrider to bumper	1	8 strips
24	249-120	£52.50	BLACK PIPING SET, 9 yards	1	exterior set
	249-220	£52.50	RED PIPING SET, 9 yards	1	
	249-320	£52.50	GREEN PIPING SET, 9 yards	1	
	249-370	NCA	CREAM PIPING SET, 9 yards	1	
	249-250	£52.50	BEIGE PIPING SET, 9 yards	1	
25	144-600	£15.60	REFLECTOR	2	
26	280-420	£13.60	FUME EXCLUDER	1	brake & clutch pedal
27	406-700	£7.70	RETAINING PLATE, pedal excluder	1	steel
28	ACA5359	£1.80	PAD, brake & clutch pedal	2	
29	408-690	£13.15	ROLLER, accelerator pedal	1	hard plastic
30	280-430	£5.90	PAD, floorboard to pedal box	1	
31	ACA5300	£2.92	PLUG, master cylinder inspection	1	LHD only
32	280-400	£21.00	FOOTWELL, driver's floorboard	1	RHD only
33	CRM2001X	£12.60	HEEL MAT, driver's floorboard	1	
34	280-260	£1.85	PAD, interior mirror	1	
35	454-040	£38.80	FUME EXCLUDER	1	steering column, leather
36	282-670	£11.50	PAD, under floor & around roll bar	2	
37	282-680	£36.50	RUBBER SNUG	1	gearshift remote control
	AAA260C	£2.62	PAD SET, fuel pump	1	2 pads

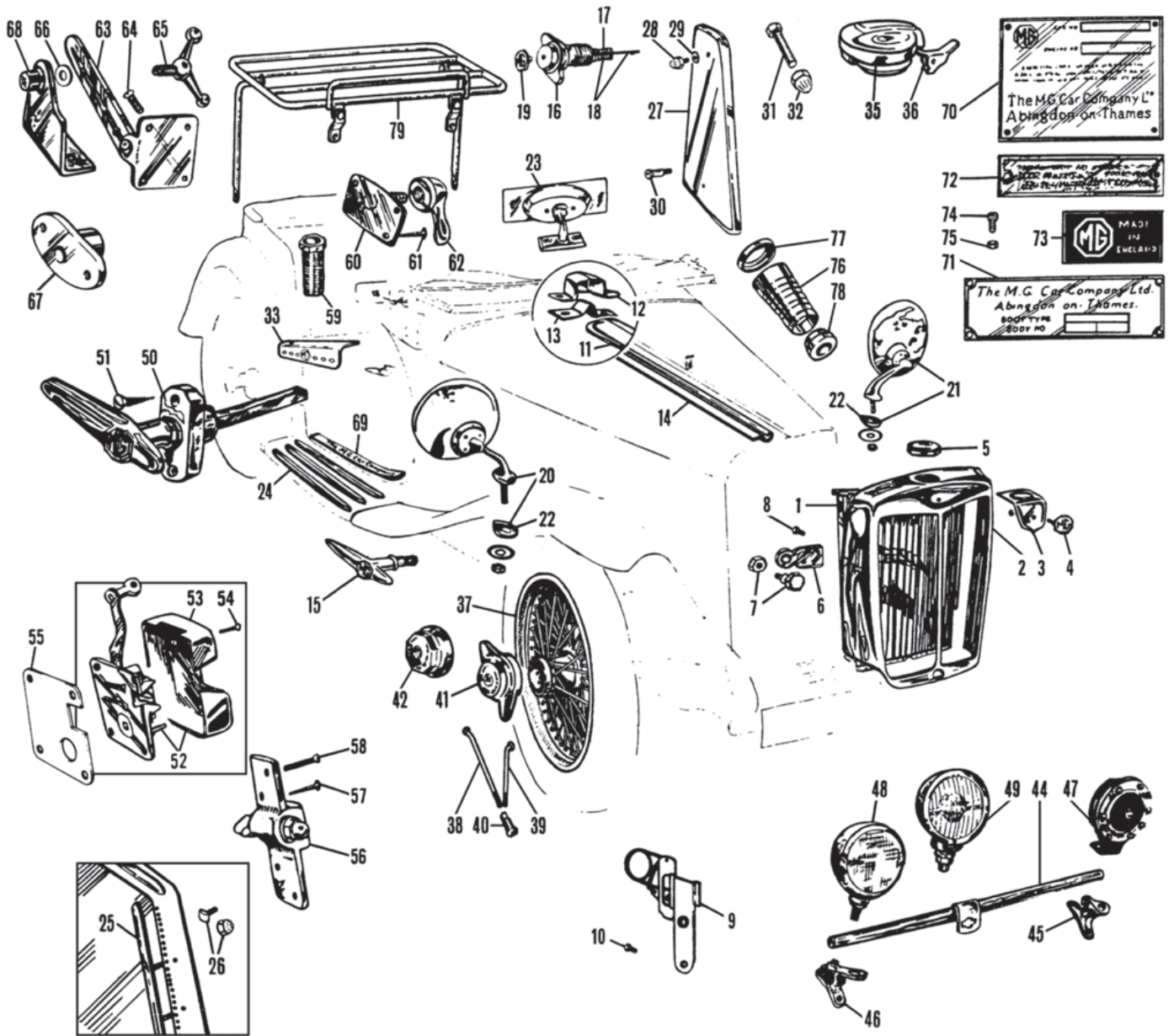

Part Number	Price £ea.	Description	Req.	Details
Exterior Body Fittings & Chrome Trim, TA-TB & TC				
Radiator Shell & Grille				
1 454-170	£80.90	SLATS, radiator shell, primed	1	
2 454-757	NCA	RADIATOR SHELL	1	not currently available
3 202-050	£158.60	FALSE NOSE, radiator shell	1	
4 E103	£25.10	MEDALLION, radiator shell	1	brown & cream
5 202-010	£52.50	RADIATOR CAP	1	
6 202-030	£35.60	BRACKET, headlamp	2	through radiator shell
7 321-288	£11.96	BOLT & NUT SET, outer bracket	2	1 of each, chrome
8 AJD6155Z	£0.70	BOLT, inner bracket, not chrome	4	

Note: Additional radiator parts are listed on page 11.

Bonnet Items & Miscellaneous Body Fittings

9 406-855	£25.10	BRACKET, bonnet catch, RH	2	} cadmium plated
406-860	£25.10	BRACKET, bonnet catch, LH	2	
10 158-018	£6.60	SCREW, (bonnet catch)	a/r	
11 453-050	£113.80	STRIP, centre bonnet	1	chrome plated brass
12 407-200	£10.40	OUTER SUPPORT, bonnet strip	2	chrome
13 407-300	£1.34	INNER SUPPORT, bonnet strip, steel	2	
14 451-675	£32.60	HINGE PLATE, welded to bonnet	2	
15 406-850	£28.30	BONNET HANDLE, RH	2	

406-840	£28.30	BONNET HANDLE, LH	2	
16 200-250	£79.30	WHEEL SPINNER, spare wheel	1	does not inc. key & spring
17 200-265	£2.87	SPRING	1	
18 200-255	£30.65	KEY & SPRING, with collar	1	
19 AAA523	£44.20	MEDALLION, spare wheel spinner	1	
20 WM1904	£12.60	MIRROR, convex lens, wing, RH	1	} reproduction of
21 WM1905	£12.60	MIRROR, convex lens, wing, LH	1	
22 280-140	£1.90	PAD, wing mirror, rubber	2	accessory
23 633-570	£112.00	DASH MIRROR, rear view	1	period accessory
24 281-008	£59.70	STRIP SET, running board, 12 pieces	1	TA & TB
25 281-238	£60.10	STRIP SET, running board, 8 pieces	1	TC
25 252-098	£146.10	STRIP SET, side screen, inc. hardware	1	} TA & TB
252-108	£134.00	STRIP SET, side screen, inc. hardware	1	TC
				with spoon ends
26 252-008	£17.50	BOLT & NUT SET, side screen strip	1	contains 63 of each
27 451-638	£172.20	END PANEL SET, fuel tank	1	2 end panels
28 320-830	£4.21	ACORN BOLT, fuel tank end panel	4	
29 011-176	£0.50	WASHER, end panel acorn bolt	4	
30 320-840	£15.55	BOLT, rear wing to fuel tank	2	not chrome
31 320-400	£1.03	BOLT, fuel tank strap mounting	2	not chrome
32 311-160	£3.55	ACORN NUT, fuel tank strap bolt	2	
33 229-655	NCA	DOOR TOP ARMREST SET	1	chrome, accessory
35 407-090	£77.10	FUEL CAP, original	1	
36 407-105	£19.75	RELEASE LEVER, fuel cap	1	

ill.	Part Number	Price £ea.	Description	Req.	Details
Wire Wheels					
37	454-607	£323.00	WIRE WHEEL, painted	5	TA To (c) 1769, outer laced 19"
	454-600	£284.00	WIRE WHEEL, painted	5	TA From (c) 1770 & TB
	454-795	£384.40	WIRE WHEEL, chrome	5	TC, centre laced 19"
38	200-010	£8.03	SPOKE, standard, long-outer	80	TA From (c) 1770 & TB,
39	200-020	£8.00	SPOKE, standard, short-inner	160	TC & centre laced 19"
40	7H1709	£0.40	NIPPLE, stainless steel	a/r	
41	AHH7317A	£23.80	WHEEL SPINNER, 2-eared, RH	4	with MG motif
	AHH7318A	£23.80	WHEEL SPINNER, 2-eared, LH	4	
42	AHH7315A	£24.00	WHEEL SPINNER, octagonal, RH	4	
	AHH7316A	£24.00	WHEEL SPINNER, octagonal, LH	4	

Badge Bar

44	451-070	£56.70	BADGE BAR	1	
45	406-310	£16.00	BRACKET, badge bar, LH	1	cast iron
46	406-320	£16.00	BRACKET, badge bar, RH	1	cast iron
47	165-900	£125.00	HORN	1	exact reproduction of the TC original
48	169-020	£425.30	FOG LAMP (Exact reproduction of Lucas FT27).	1	TA-TB & TC To (c) 4738
49	169-000	NCA	FOG LAMP (Exact reproduction of Lucas SFT462).	1	TC From (c) 4739

Handles/Locks, ID Plates & Miscellaneous Fittings

50	401-490	£29.50	EXTERIOR HANDLE, RH	1	
	401-480	£29.50	EXTERIOR HANDLE, LH	1	
51	323-540	£1.03	SCREW, handle securing	4	
52	401-200	£68.00	DOOR LOCK, RH	1	includes cover and screws
	401-100	£68.00	DOOR LOCK, LH	1	
53	401-250	£12.10	COVER, door lock, RH	1	
	401-150	£12.10	COVER, door lock, LH	1	
54	323-718	£5.90	SCREW SET, door lock cover	1	4 screws
55	401-170	£7.00	SHIM, door lock, 1/16"	a/r	
56	401-308	£44.50	STRIKER PLATE & WEDGE	2	includes screws
57	323-540	£1.03	WOOD SCREW, striker securing	4	
58	323-390	£2.98	MACHINE SCREW, striker securing	4	
59	405-400	£5.80	SOCKET, side screen, (in door top)	2	
60	408-615	£19.45	PLATE, side screen mounting	4	TA & TB
	405-200	£10.60	PLATE, side screen mounting	4	TC, (illustrated)
61	323-540	£1.03	WOOD SCREW, side screen plate	12	TA-TB & TC
	323-390	£2.98	MACHINE SCREW, side screen plate	4	TC
62	MB19331	£5.40	NUT, side screen plate	4	
63	406-110	£34.70	BRACKET, seat back	2	
64	323-090	£1.50	SCREW, seat back bracket	8	
65	406-100	£9.85	WING BOLT, seat adjusting	2	
66	324-610	£0.30	FIBRE WASHER	2	
67	408-625	£60.00	BRACKET, wheel arch, RH	1	TA & TB
	408-635	£60.00	BRACKET, wheel arch, LH	1	
68	406-130	£55.00	BRACKET, RH wheel arch	1	TC
	406-120	£55.00	BRACKET, LH wheel arch	1	
69	451-398	£40.00	THRESHOLD PLATE SET, (pair) (2 plates etched with 'The MG Car Company Ltd').	1	
70	408-405	£5.05	CHASSIS ID PLATE	1	TA
	408-415	£4.21	CHASSIS ID PLATE	1	TB
	408-700	£4.78	CHASSIS ID PLATE	1	TC
71	408-730	£5.10	BODY ID PLATE	1	
72	408-780	£3.60	PATENT NUMBER PLATE	1	
73	408-760	£3.55	'MADE IN ENGLAND' PLATE	1	
74	FAS3	£0.44	SCREW, brass, ID plates	a/r	
75	FAS4	£0.50	NUT, ID plate screw	a/r	
76	1D6163	£23.50	SPRING COVER, steering column	1	TA late, TB & TC
77	108611	£7.40	CAP, spring cover	1	spline fitting type
78	262-290	£20.30	WASHER, spring cover, not chrome	1	wheel only

Boot Rack, (Factory Style)

79	244-400	£235.00	BOOT RACK	1	chrome
	244-410	£236.70	BOOT RACK	1	stainless steel

Windscreen Components

80	CRCP329	£2.52	'AUSTER' NAME PLATE	1	
81	FAS1	£0.30	RIVET, name plate securing	2	
82	280-290	£11.50	STRIP, frame to cowl, rubber	1	
83	280-300	£11.60	STRIP, glass to frame, rubber	1	
84	AA45166	£7.00	WING BOLT, hood to windscreen	2	
85	408-600	£15.00	TOP CORNER BRACKET, LH	1	drilled
	408-610	£15.00	TOP CORNER BRACKET, RH	1	
	408-607	£9.50	TOP CORNER BRACKET, LH	1	not drilled
	408-617	£7.45	TOP CORNER BRACKET, RH	1	

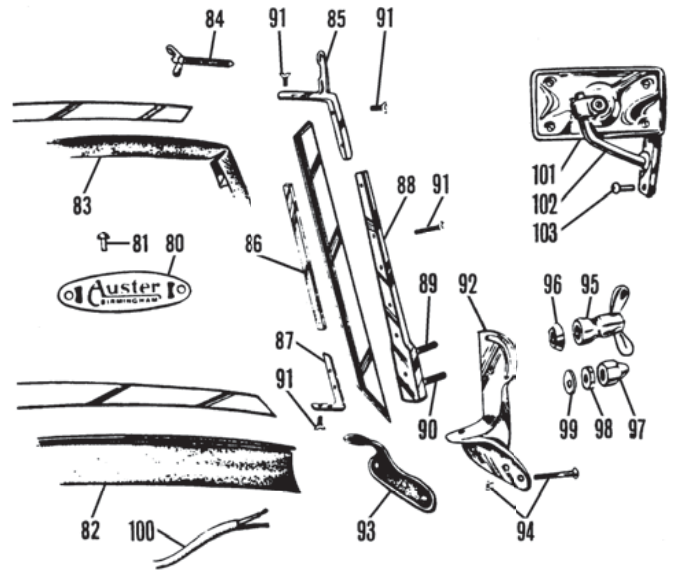

ill.	Part Number	Price £ea.	Description	Req.	Details
86	408-820	£10.05	THREADED STRIP, side windscreen	2	
87	408-620	£12.05	BRACKET, bottom corner	2	
88	408-235	NCA	SIDE SUPPORT, LH	1	
	408-245	NCA	SIDE SUPPORT, RH	1	
89	408-285	£2.45	STUD, upper	2	windscreen
90	408-295	£7.05	STUD, lower	2	side support
91	323-908	£21.80	SCREW SET, windscreen frame	1	28 screws
92	408-655	NCA	COWL BRACKET, LH	1	
	408-665	NCA	COWL BRACKET, RH	1	
93	281-178	£5.15	PAD SET, bracket to cowl	1	2 rubber pads
94	323-778	£12.32	SCREW SET, bracket to cowl	1	6 screws & nuts
95	225-400	£11.10	WING NUT	2	
96	408-660	£2.77	CONE SPACER, wing nut	2	
97	311-170	£6.60	DOME NUT, side support	2	
98	311-180	£1.44	LOCK NUT, dome nut	2	
99	408-650	£2.60	'D' WASHER, lock nut	2	
100	162-020	£10.10	WIPER 'WIRE', wiper motor, 8'	1	
101	407-350	£215.00	MIRROR, windscreen, RH	1	with bracket
	407-347	£146.60	MIRROR HEAD	1	TC type without medallion
	407-357	£13.25	GLASS LENS	1	
102	407-400	£62.50	BRACKET, for mirror, RH	1	
	407-500	£62.50	BRACKET, for mirror, LH*	1	optional
103	323-090	£1.50	SCREW	2	

*Note: See page 57 for alternative LH mirror bracket, (that does not require drilling).

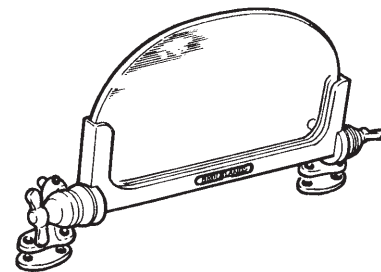

Brooklands Type Aero-Screens

This period style aero-screen incorporates a polished cast aluminium frame, chrome plated brass fittings and laminated safety glass. While similar to factory aero-screens they do not fit directly onto the T Series scuttle, mounting brackets are therefore supplied, sold individually.

700896	£71.50	AERO-SCREEN KIT, reproduction	2
AD606063	£0.29	SCREW, foot to scuttle	8

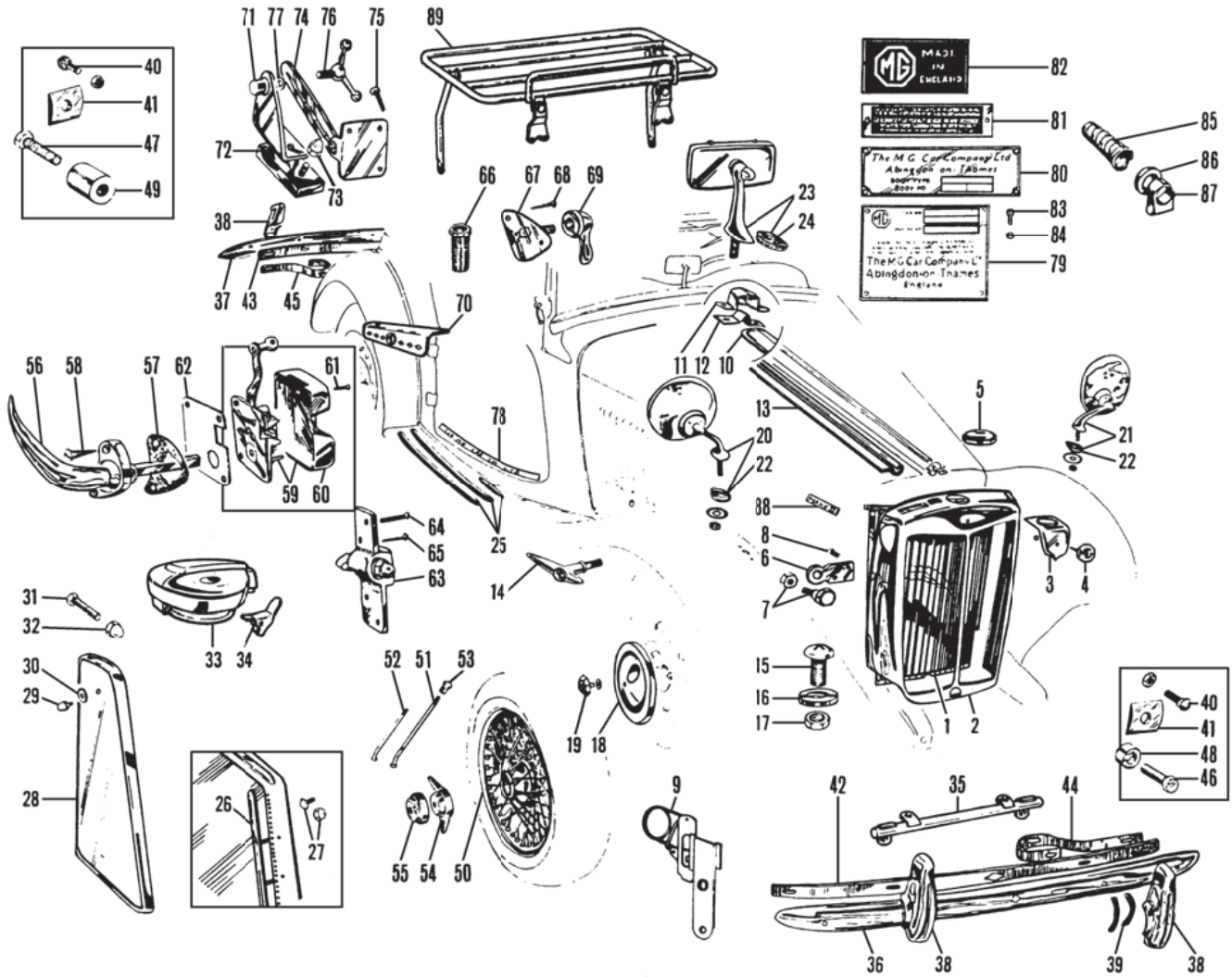

Part Number	Price £ea.	Description	Req.	Details
Exterior Body Fittings & Chrome Trim, TD				
Radiator Shell & Grille				
1	454-170	£80.90 SLATS, radiator shell, primed	1	
2	454-757	NCA RADIATOR SHELL	1	
3	202-050	£158.60 FALSE NOSE, radiator shell	1	
4	E103	£25.10 MEDALLION, radiator shell	1	brown & cream
5	202-010	£52.50 RADIATOR CAP	1	
6	202-030	£35.60 BRACKET, headlamp	2	through radiator shell
7	321-288	£11.96 BOLT & NUT SET, outer bracket	2	(1 of each), chrome
8	AJD6155Z	£0.70 BOLT, inner bracket, not chrome	4	

*Note: Additional radiator parts are listed on page 11.

Bonnet Items & Miscellaneous Body Fittings

9	406-855	£25.10 BRACKET, bonnet catch, RH	2	
	406-860	£25.10 BRACKET, bonnet catch, LH	2	
10	453-050	£113.80 STRIP, centre bonnet	1	chrome plated brass
11	407-200	£10.40 OUTER SUPPORT, bonnet strip	2	chrome
12	407-300	£1.34 INNER SUPPORT, bonnet strip	2	steel
13	451-675	£32.60 HINGE PLATE, welded to bonnet	2	
14	406-850	£28.30 BONNET HANDLE, RH	2	
	406-840	£28.30 BONNET HANDLE, LH	2	
15	323-160	£3.00 SCREW, splash apron	6	
16	324-455	£0.60 WASHER, splash apron screw	6	
17	AJD8105Z	£0.18 NUT, splash apron screw	a/r	
18	ACH8304	£25.00 HUB CAP, includes medallion	5	original type
	200-235	£21.00 HUB CAP, with hole	5	less medallion
19	200-277	£6.60 MEDALLION	5	
20	WM1904	£12.60 MIRROR, convex lens, wing, RH	1	reproduction of
21	WM1905	£12.60 MIRROR, convex lens, wing, LH	1	Lucas
22	280-140	£1.90 PAD, wing mirror, rubber	2	period accessory
23	165-090	£42.20 DASH MIRROR, rear view	1	

Part Number	Price £ea.	Description	Req.	Details
24	280-260	£1.85 PAD, dash mirror, rubber	1	
25	281-248	£78.00 STRIP SET, running board	1	6 pieces aluminium & rubber
26	252-208	£134.00 STRIP SET, side screen	1	2 bow hoods To (c) 20695 RHD (c) 20373 LHD, with 2 free standing metal bows
	252-308	£134.00 STRIP SET, side screen	1	3 bow hoods From (c) 20696 RHD (c) 20374 LHD, with 3 free-standing metal bows
27	252-018	£34.70 BOLT & NUT SET, side screen strip	1	58 of each
28	451-648	£178.80 END PANEL SET, fuel tank	1	2 end panels
29	320-830	£4.21 ACORN BOLT, fuel tank end panel	4	
30	011-176	£0.50 WASHER, end panel acorn bolt	4	
31	320-400	£1.03 BOLT, fuel tank strap mounting	4	not chrome
32	311-160	£3.55 ACORN NUT, fuel tank strap bolt	4	
33	407-090	£77.10 FUEL CAP	1	TC type
34	407-105	£19.75 RELEASE LEVER, fuel cap	1	
35	451-060	£68.50 BADGE BAR	1	

Bumpers & Fittings

36	AAA4936	£125.00 BUMPER FACE BAR, front	1	
37	AAA4941	£126.30 BUMPER FACE BAR, rear	1	
38	27H9612	£51.50 OVERRIDER, front & rear	4	with bolts
39	37H9871M	£1.20 PACKING SET, overrider	4	8 pieces
40	554700K	£1.52 BOLT, bumper, with nut	5	
41	ACC5811	£2.15 PACKING, bumper to back bar	9	
42	AAA4937	£36.50 BACK BAR, front bumper	1	
43	453-060	£33.50 BACK BAR, rear bumper	1	
44	454-020	£40.00 BRACKET, front bumper	2	
45	454-030	£37.90 BRACKET, rear bumper	2	
46	320-720	£3.66 BOLT, front bracket to chassis	2	
47	320-730	£3.66 BOLT, rear bracket to chassis	2	
48	400-100	£5.40 SPACER, front bracket to chassis	2	
49	400-200	£8.30 SPACER, rear bracket to chassis	2	

ill. Part Number Price £ea. Description Req. Details

Wire Wheel Conversion Kit

The following wire wheel conversion kits are designed to convert your disc wheeled TD to wire wheels. Each kit includes four splined hubs, four brake drums, one spare wheel adaptor with spinner (to convert spare wheel carrier to wire wheels), and all the studs, nuts, etc... for an easy installation. These kits will enhance the appearance of any TD and are identical to the original factory option for the TF.

Note: Our conversion kits do not include wheel or spinners. Parts required in addition to the conversion kit are listed here.

111-518	£790.00	WIRE WHEEL CONVERSION KIT	1
---------	---------	---------------------------	---

Wire Wheels

50	WWP450	£154.80	WIRE WHEEL, painted	5	48 spoke
	WWC450	£211.00	WIRE WHEEL, chrome	5	
	WWP452	£154.20	WIRE WHEEL, painted	5	60 spoke
	WWC452	£222.20	WIRE WHEEL, chrome	5	
51	7H1805	£3.90	SPOKE, long-outer, standard	80	48 spoke
	7H1805CP	£7.12	SPOKE, long-outer, chrome	80	
	17H8619	£3.82	SPOKE, long-outer, standard	100	60 spoke
	17H8619CP	£7.12	SPOKE, long-outer, chrome	100	
52	7H1806	£3.91	SPOKE, short-inner, standard	160	48 spoke
	7H1806CP	£7.12	SPOKE, short-inner, chrome	160	
	17H8620	£3.91	SPOKE, short-inner, standard	200	60 spoke
	17H8620CP	£7.52	SPOKE, short-inner, chrome	200	
53	7H1709	£0.40	NIPPLE, stainless steel	a/r	
	37H3651	£1.64	NIPPLE, chrome	a/r	
54	AHH7317A	£23.80	WHEEL SPINNER, 2-eared, RH	4	with MG motif
	AHH7318A	£23.80	WHEEL SPINNER, 2-eared, LH	4	
55	AHH7315A	£24.00	WHEEL SPINNER, octagonal, RH	4	
	AHH7316A	£24.00	WHEEL SPINNER, octagonal, LH	4	

Handles/Locks, ID Plates & Miscellaneous Fittings

56	401-657	£21.00	EXTERIOR HANDLE	2	
57	401-634	£1.20	GASKET, exterior handle	1	
	401-648	£1.90	GASKET SET, exterior handle	1	2 gaskets
58	323-530	£1.10	SCREW, handle securing	4	
59	401-200	£68.00	DOOR LOCK, RH	1	includes cover and screws
	401-100	£68.00	DOOR LOCK, LH	1	
60	401-250	£12.10	COVER, door lock, RH	1	
	401-150	£12.10	COVER, door lock, LH	1	
61	323-718	£5.90	SCREW SET, door lock cover	1	4 screws
62	401-170	£7.00	SHIM, door lock, 1/16"	a/r	
63	401-408	£44.50	STRIKER PLATE & WEDGE	2	includes screws
64	AJD2246	£0.46	MACHINE SCREW, striker securing	4	
65	323-530	£1.10	WOOD SCREW, striker securing	4	
66	405-400	£5.80	SOCKET, side screen, in door top	2	
67	AAA5154	£7.40	PLATE, side screen mounting	4	
68	323-530	£1.10	SCREW, side screen plate	12	
69	MB19331	£5.40	NUT, side screen plate	4	
70	229-655	NCA	DOOR TOP ARMREST SET, chrome	1	accessory
71	406-140	£22.00	BRACKET, wheel arch	2	
72	406-150	£6.46	PLATE, wheel arch bracket retaining	2	not chrome
73	406-160	£3.76	DOME NUT, wheel arch bracket	4	
74	406-110	£34.70	BRACKET, seat back	2	
75	AJD2246	£0.46	SCREW, seat back bracket	8	
76	406-100	£9.85	WING BOLT, seat adjusting	2	
77	324-610	£0.30	FIBRE WASHER	2	
78	451-398	£40.00	THRESHOLD PLATE SET, (pair)	1	
			(2 plates etched with 'The MG Car Company Ltd').		
79	CRB195	£6.80	CHASSIS ID PLATE	1	
80	408-730	£5.10	BODY ID PLATE	1	
81	408-780	£3.60	PATENT NUMBER PLATE	1	
82	408-760	£3.55	'MADE IN ENGLAND' PLATE	1	
83	FAS3	£0.44	SCREW, brass, ID plates	10	
84	FAS4	£0.50	NUT, ID plate screw	10	
85	AAA1651	£10.20	SPRING COVER, steering column	1	
86	AAA1650	£3.22	CAP, spring cover	1	
87	AAA192	£7.36	CLAMP ASSEMBLY, column	1	includes nut, bolt & washer
88	408-200	£25.50	MEDALLION 'MARK II'	2/3	TD, MkII

Boot Rack (Factory Style)

89	244-500	£168.50	BOOT RACK, chrome	1
	244-510	£236.70	BOOT RACK, stainless steel	1
	243-705	£136.50	BOOT RACK, Runyon type	1

Windscreen Components

95	CRCP329	£2.52	'AUSTER' NAME PLATE	1
96	FAS1	£0.30	RIVET, name plate securing	2
97	280-290	£11.50	STRIP, frame to cowl, rubber	1

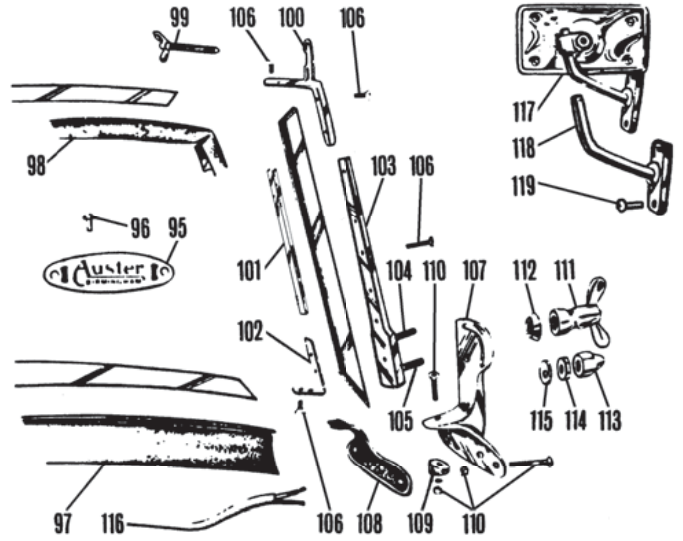

98	280-300	£11.60	STRIP, glass to frame, rubber	1	
99	AAA5166	£7.00	WING BOLT, hood to windscreen	2	
100	408-600	£15.00	TOP CORNER BRACKET, LH	1	drilled
	408-610	£15.00	TOP CORNER BRACKET, RH	1	
	408-607	£9.50	TOP CORNER BRACKET, LH	1	not drilled
	408-617	£7.45	TOP CORNER BRACKET, RH	1	
101	408-630	£21.00	THREADED STRIP, side windscreen	2	
102	408-620	£12.05	BRACKET, bottom corner	2	
103	408-230	NCA	SIDE SUPPORT, LH	1	
	408-240	NCA	SIDE SUPPORT, RH	1	
104	408-285	£2.45	STUD, upper, windscreen side support	2	
105	408-295	£7.05	STUD, lower, windscreen side support	2	
106	323-918	£29.00	SCREW SET, windscreen frame	1	26 screws
107	408-315	NCA	COWL BRACKET, LH	1	
	408-325	NCA	COWL BRACKET, RH	1	
108	281-188	£5.35	PAD SET, bracket to cowl, rubber	1	2 rubber pads
109	408-250	£3.92	SPACER, bracket to cowl	2	
110	323-898	£11.04	SCREW SET, bracket to cowl	1	8 screws & nuts
111	225-400	£11.10	WING NUT	2	
112	408-660	£2.77	CONE SPACER, wing nut	2	
113	311-170	£6.60	DOME NUT, side support	2	
114	311-180	£1.44	LOCK NUT, dome nut	2	
115	408-650	£2.60	'D' WASHER, lock nut	2	
116	162-020	£10.10	WIRE, wiper motor	1	
117	407-350	£215.00	SIDE MIRROR, windscreen, RH	1	with bracket TC style
	407-347	£146.60	MIRROR HEAD	1	TC type without medallion
	407-357	£13.25	GLASS LENS	1	
118	407-400	£62.50	BRACKET, for mirror, RH	1	
	407-500	£62.50	BRACKET, for mirror, LH*	1	
119	AJD2246	£0.46	SCREW	2	

*Note: Windscreen bracket will require drilling and tapping to mount above mirrors. See page 57 for alternative LH mirror bracket (that does not require drilling).

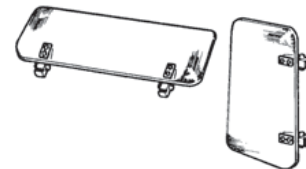

Wind Wings & Period Sun Visors

Our classic polished clear Plexiglas wind wings eliminate side draughts to make motoring in your T Series MG more pleasurable. Sold in pairs complete with chrome mounting hardware. Installation is easy, no windscreen frame drilling required. The green tinted Plexiglas sun visors are easily fitted and require no drilling, they have chrome plated mountings similar to the wind wings and are a most useful accessory. Sold individually.

240-100	£90.00	WIND WING SET, accessory	1
MM240-300	£24.50	SUN VISOR, accessory	2

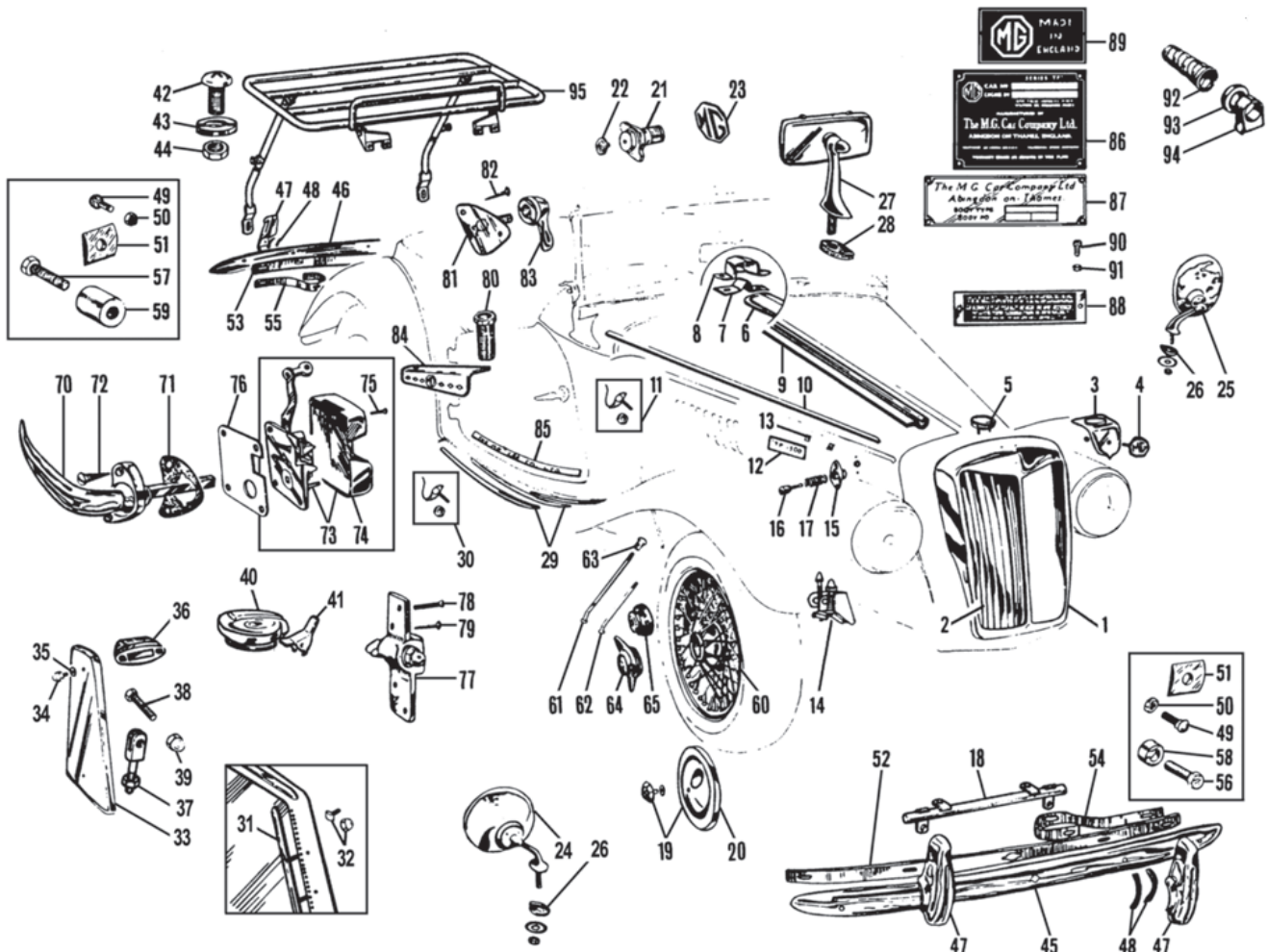

Part Number	Price £ea.	Description	Req.	Details
Body Fittings & Chrome Trim, TF				
Radiator Shell & Grille				
1	NCA	RADIATOR SHELL	1	
2	£197.00	GRILLE SLAT SET, radiator shell	1	12 slats
	£22.00	451-030 GRILLE SLAT, radiator shell, each	12	
3	NCA	FALSE NOSE, radiator shell	1	
4	£23.00	ARH900 MEDALLION, radiator shell	1	black & white
5	NCA	RADIATOR CAP, dummy	1	

Part Number	Price £ea.	Description	Req.	Details
Bonnet Items & Miscellaneous Body Fittings				
6	£113.80	453-050 STRIP, centre bonnet	1	chrome plated brass
7	£10.40	407-200 OUTER SUPPORT, bonnet strip	2	chrome
8	£1.34	407-300 INNER SUPPORT, bonnet strip	2	steel
9	£32.60	451-675 HINGE PLATE, welded to bonnet	2	
10	£52.30	453-070 STRIP, bonnet side	2	chrome plated brass
11	£0.48	AHH6360 STUD PLATE & NUT, bonnet strip	10	5 per strip
12	£17.80	408-300 MEDALLION, 'TF 1500'	2	as fitted
13	£0.40	326-510 SPIRE CLIP, medallion attaching	4	
14	NCA	457-895 BONNET CATCH, RH	2	
	NCA	457-905 BONNET CATCH, LH	2	
15	£56.80	406-950 HOUSING, bonnet button	4	
16	£40.00	406-955 BUTTON, bonnet	4	
17	£5.54	329-090 SPRING, for button	4	
18	£68.50	451-060 BADGE BAR	1	
19	£25.00	ACH8304 HUB CAP, includes medallion	5	original type
	£21.00	200-235 HUB CAP, with hole	5	less medallion
20	£6.60	200-277 MEDALLION	5	
21	£80.30	200-260 WHEEL SPINNER, spare wheel	1	
22	£23.00	ARH900 MEDALLION, spare wheel spinner	1	
23	£36.90	AAA5021 MEDALLION, spare wheel	1	steel wheels
24	£12.60	WM1904 MIRROR, convex lens, wing, RH	1	reproduction of
25	£12.60	WM1905 MIRROR, convex lens, wing, LH	1	Lucas
26	£1.90	280-140 PAD, wing mirror, rubber	2	period accessory

Part Number	Price £ea.	Description	Req.	Details
27	£42.20	165-090 DASH MIRROR, rear view	1	
28	£1.85	280-260 PAD, dash mirror, rubber	1	
29	£139.40	451-745 STRIP SET, running boards	1	chrome-plated brass, (set of 6)
30	£0.48	AHH6360 STUD & NUT, running board strips	26	
31	£134.00	252-408 STRIP SET, side screen, complete	1	stainless steel
32	£34.70	252-018 BOLT & NUT SET, side screen strip	1	58 of each
33	£172.20	451-658 END PANEL SET, fuel tank	1	2 end panels
34	£4.21	320-830 ACORN BOLT, fuel tank end panel	4	
35	£0.50	011-176 WASHER, end panel acorn bolt	4	
36	£22.95	407-110 TOP BRACKET, fuel tank strap	2	chrome
37	£42.00	449-005 BOTTOM BRACKET, fuel tank strap	2	
38	£0.67	AJD6216Z BOLT, fuel tank strap mounting	4	not chrome
39	£3.55	311-160 ACORN NUT, petrol tank strap bolt	4	
40	£77.10	407-090 FUEL CAP, original type	1	
41	£19.75	407-105 RELEASE LEVER, fuel cap	1	
42	£3.00	323-160 SCREW, splash apron	2	
43	£0.60	324-455 WASHER, splash apron screw	2	
44	£0.18	AJD8105Z NUT, splash apron screw	2	

Part Number	Price £ea.	Description	Req.	Details
Bumpers & Fittings				
45	£125.00	AAA4936 BUMPER FACE BAR, front	1	
46	£140.00	ACG5024 BUMPER FACE BAR, rear	1	
47	£51.50	27H9612 OVERRIDER, front & rear	4	with bolts
48	£1.20	37H9871M PACKING SET, overrider	1	8 pieces
49	£1.52	554700K BOLT, bumper	6	
50	£0.12	GHF202 NUT, bumper bolt	6	
51	£2.15	ACC5811 PACKING, bumper to back bar	10	
52	£36.50	AAA4937 BACK BAR, front bumper	1	
53	£33.50	453-060 BACK BAR, rear bumper	1	
54	£40.00	454-020 BRACKET, front bumper	2	
55	£37.90	454-030 BRACKET, rear bumper	2	
56	£3.66	320-720 BOLT, front bracket to chassis	2	
57	£3.66	320-730 BOLT, rear bracket to chassis	2	
58	£5.40	400-100 SPACER, front bracket to chassis	2	
59	£8.30	400-200 SPACER, rear bracket to chassis	2	

ill.	Part Number	Price Eea.	Description	Req.	Details
Wire Wheels					
60	WWP450	£154.80	WIRE WHEEL, painted	5	48 spoke
	WWC450	£211.00	WIRE WHEEL, chrome	5	
	WWP452	£154.20	WIRE WHEEL, painted	5	60 spoke
	WWC452	£222.20	WIRE WHEEL, chrome	5	
61	7H1805	£3.90	SPOKE, long-outer, standard	80	48 spoke
	7H1805CP	£7.12	SPOKE, long-outer, chrome	80	
	17H8619	£3.82	SPOKE, long-outer, standard	100	60 spoke
	17H8619CP	£7.12	SPOKE, long-outer, chrome	100	
62	7H1806	£3.91	SPOKE, short-inner, standard	160	48 spoke
	7H1806CP	£7.12	SPOKE, short-inner, chrome	160	
	17H8620	£3.91	SPOKE, short-inner, standard	200	60 spoke
	17H8620CP	£7.52	SPOKE, short-inner, chrome	200	
63	7H1709	£0.40	NIPPLE, stainless steel	a/r	
	37H3651	£1.64	NIPPLE, chrome	a/r	
64	AHH7317A	£23.80	WHEEL SPINNER, 2-eared, RH	4	
	AHH7318A	£23.80	WHEEL SPINNER, 2-eared, LH	4	with MG motif
65	AHH7315A	£24.00	WHEEL SPINNER, octagonal, RH	4	
	AHH7316A	£24.00	WHEEL SPINNER, octagonal, LH	4	

Handles/Locks, ID Plates & Miscellaneous Fittings

70	401-657	£21.00	EXTERIOR HANDLE	2	
71	401-634	£1.20	GASKET, exterior handle	1	
	401-648	£1.90	GASKET SET, exterior handle	1	2 gaskets
73	401-200	£68.00	DOOR LOCK, RH	1	includes
	401-100	£68.00	DOOR LOCK, LH	1	cover & screws
74	401-250	£12.10	COVER, door lock, RH	1	
	401-150	£12.10	COVER, door lock, LH	1	
75	323-718	£5.90	SCREW SET, door lock cover	1	4 screws
76	401-170	£7.00	SHIM, door lock, 1/16"	a/r	
77	401-408	£44.50	STRIKER PLATE & WEDGE	2	includes screws
78	AJD2246	£0.46	MACHINE SCREW, striker securing	4	
79	323-530	£1.10	WOOD SCREW, striker securing	4	
80	405-400	£5.80	SOCKET, side screen, in door top	2	
81	AAA5154	£7.40	PLATE, side screen mounting	4	
82	323-530	£1.10	SCREW, side screen plate	12	
83	MB19331	£5.40	NUT, side screen plate	4	
84	229-655	NCA	DOOR TOP ARMREST SET	1	chrome accessory

Note: Additional door parts are listed on page 46.

85	451-398	£40.00	THRESHOLD PLATE SET, (pair) (2 plates etched with 'The MG Car Company Ltd').	1	
86	408-710	£6.30	CHASSIS ID PLATE	1	
87	408-730	£5.10	BODY ID PLATE	1	
88	CRCP367	£3.00	PATENT NUMBER PLATE	1	
89	408-760	£3.55	'MADE IN ENGLAND' PLATE	1	
90	FAS3	£0.44	SCREW, ID plate	a/r	
91	FAS4	£0.50	NUT, ID plate screw	a/r	
92	AAA1651	£10.20	SPRING COVER, steering column	1	
93	AAA1650	£3.22	CAP, spring cover	1	
94	AAA192	£7.36	CLAMP ASSEMBLY, column	1	includes nut, bolt & washer

Boot Rack, (Factory Style)

95	244-600	£235.00	BOOT RACK	1	chrome
	244-610	£236.70	BOOT RACK	1	stainless steel

Windscreen Components

100	CRCP329	£2.52	'AUSTER' NAME PLATE	1	
101	FAS1	£0.30	RIVET, name plate securing	1	
102	280-290	£11.50	STRIP, frame to cowl, rubber	1	
103	280-300	£11.60	STRIP, glass to frame, rubber	1	
104	AAA5166	£7.00	WING BOLT, hood to windscreen	2	
105	408-600	£15.00	TOP CORNER BRACKET, LH	1	drilled
	408-610	£15.00	TOP CORNER BRACKET, RH	1	
	408-607	£9.50	TOP CORNER BRACKET, LH	1	not drilled
	408-617	£7.45	TOP CORNER BRACKET, RH	1	
106	408-630	£21.00	THREADED STRIP, side windscreen	2	
107	408-620	£12.05	BRACKET, bottom corner	2	
108	408-230	NCA	SIDE SUPPORT, LH	1	
	408-240	NCA	SIDE SUPPORT, RH	1	
109	408-285	£2.45	STUD, upper, windscreen side support	2	
110	408-295	£7.05	STUD, lower, windscreen side support	2	
111	323-918	£29.00	SCREW SET, windscreen frame	1	26 screws
112		NCA	COWL BRACKET, LH	1	
		NCA	COWL BRACKET, RH	1	
113	281-188	£5.35	PAD SET, bracket to cowl	1	2 rubber pads
114	408-250	£3.92	SPACER, bracket to cowl	2	
115	323-898	£11.04	SCREW SET, bracket to cowl	1	8 screws & nuts
116	225-400	£11.10	WING NUT	2	

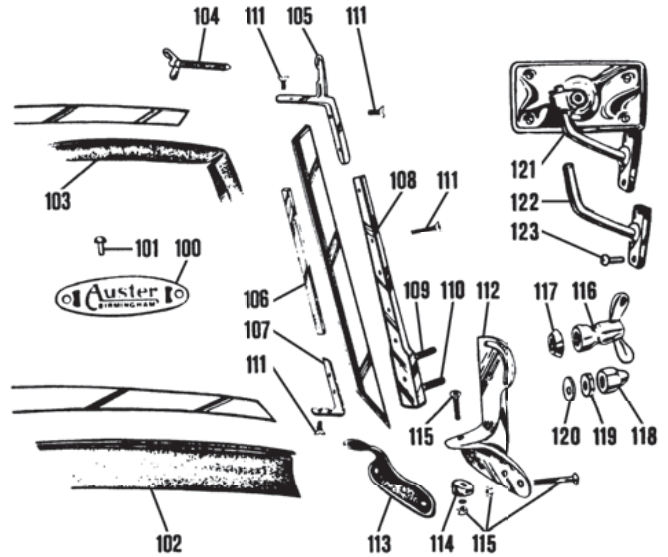

ill.	Part Number	Price Eea.	Description	Req.	Details
	117 408-660	£2.77	CONE SPACER, wing nut	2	
	118 311-170	£6.60	DOME NUT, side support	2	
	119 311-180	£1.44	LOCK NUT, dome nut	2	
	120 408-650	£2.60	'D' WASHER, lock nut	2	
	121 407-350	£215.00	SIDE MIRROR, windscreen, RH*	1	with bracket, TC style
	407-347	£146.60	MIRROR HEAD	1	TC type without medallion
	407-357	£13.25	GLASS LENS	1	
	122 407-400	£62.50	BRACKET, for mirror, RH	1	
	407-500	£62.50	BRACKET, for mirror, LH*	1	
	123 AJD2246	£0.46	SCREW	2	

*Note: Windscreen bracket will require drilling and tapping to mount the above mirrors. For an alternative bracket that doesn't require drilling, read on.

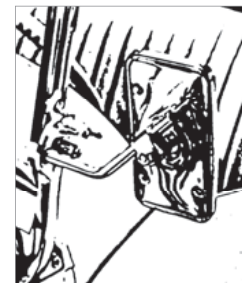

Easy Fit (Side) Mirror Bracket & Stem

The TA-TB-TC mirror bracket was attached to the windscreen by two screws and, if you wanted to fit the same optional mirror to the passenger side of the windscreen on TD and TF models, then holes had to be drilled and tapped in the windscreen frame. Our new style of bracket (supplied with dome nut, taper & flat washers) is suitable for right or left hand installation, fitting directly into the securing slot of the windscreen when in the lowered position. Now you can put down that electric drill and stop trembling because no drilling is required! Moreover, the bracket is not a permanent fitment. Using the 407-347 mirror head, excellent rear visibility is offered - even when the high mount luggage rack is installed.

407-488	£32.60	BRACKET KIT, (side mirror) (Fits left or right hand side of windscreen).	a/r
407-347	£146.60	MIRROR HEAD	a/r

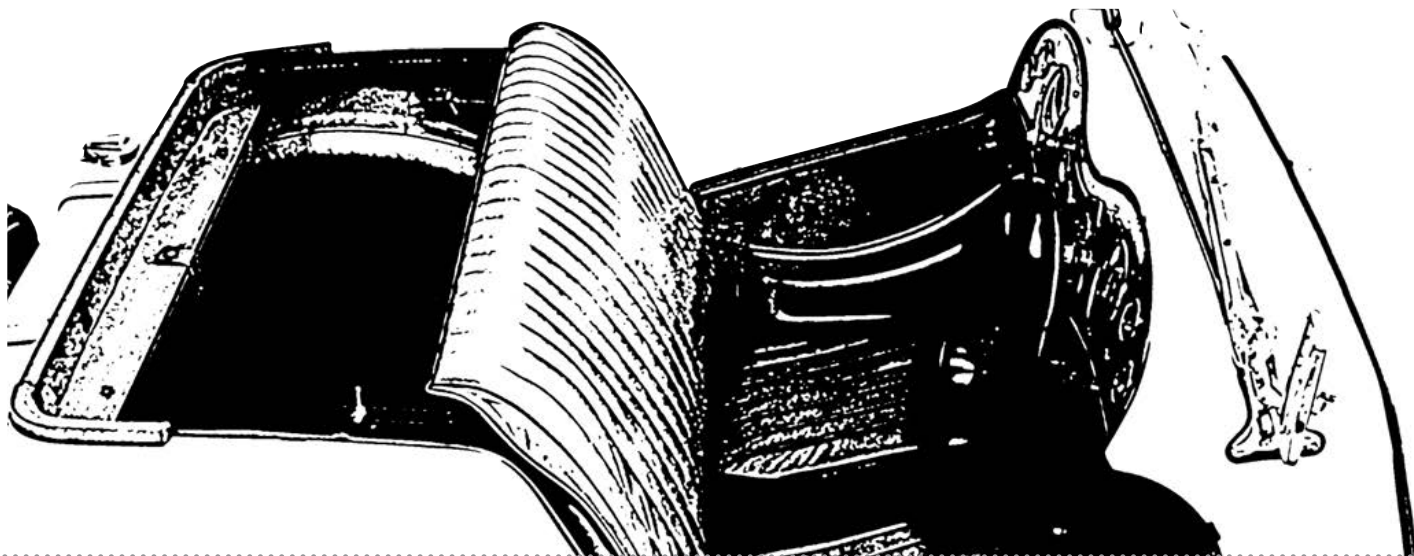

iii. Part Number Price £ea. Description Req. Details

Interior Trim

Our complete range of interior trim for MG T Types is designed to delight the purists. We incorporate many original design features which a custom upholstery shop could not hope to duplicate. All leather and vinyl materials have been carefully selected for texture and are production-dyed to recreate the original colours, beige (TA-TB only), biscuit, green & red. We also offer a selection of alternative colours for those looking to personalise their interiors; black, tan & honey tan.

Trim Panel Kits

All components are pre-cut and pre-sewn by our own upholstery shop with extraordinary results. Every stitch follows the course of the original. The hidem tacking strip matches perfectly and is sewn through the plywood for exact placement and easy installation. The door pockets are stitched to the door panel and topped off with genuine leather. Leather piping also finishes off the door tops. Wheel arch covers are also bound with the slot for TC seat back brackets (where required). Material is also included to cover the dash & sidescreen compartment, interior piping etc. This attention to detail ensures you get the best interior for your T Type.

Trim Panel Kits are available in a choice of leather panel & vinyl trim, or vinyl panel & vinyl trim.

Leather Panel & Vinyl Trim Kits

245-260	£525.00	TRIM KIT, leather & vinyl trim, biscuit	1	TC
245-270	NCA	TRIM KIT, leather & vinyl trim, black	1	TC
245-250	£525.00	TRIM KIT, leather & vinyl trim, green	1	TC
245-542	£525.00	TRIM KIT, leather & vinyl trim, honey tan	1	TC
245-240	£525.00	TRIM KIT, leather & vinyl trim, red	1	TC
245-540	£525.00	TRIM KIT, leather & vinyl trim, tan	1	TC
245-300	£631.00	TRIM KIT, leather & vinyl trim, biscuit	1	TD
245-310	£631.00	TRIM KIT, leather & vinyl trim, black	1	TD
245-290	£631.00	TRIM KIT, leather & vinyl trim, green	1	TD
245-552	£631.00	TRIM KIT, leather & vinyl trim, honey tan	1	TD
245-280	£631.00	TRIM KIT, leather & vinyl trim, red	1	TD
245-550	£631.00	TRIM KIT, leather & vinyl trim, tan	1	TD
245-340	£525.00	TRIM KIT, leather & vinyl trim, biscuit	1	TF
245-470	£441.00	TRIM KIT, leather & vinyl trim, black	1	TF
245-330	£525.00	TRIM KIT, leather & vinyl trim, green	1	TF
245-562	£525.00	TRIM KIT, leather & vinyl trim, honey tan	1	TF
245-320	£525.00	TRIM KIT, leather & vinyl trim, red	1	TF
245-560	£525.00	TRIM KIT, leather & vinyl trim, tan	1	TF

Vinyl Panel & Vinyl Trim Kits

449-475	£518.00	TRIM KIT, vinyl & vinyl trim, beige	1	TA-TB
449-470	£518.00	TRIM KIT, vinyl & vinyl trim, green	1	TA-TB
449-480	£518.00	TRIM KIT, vinyl & vinyl trim, red	1	TA-TB
245-380	£522.00	TRIM KIT, vinyl & vinyl trim, biscuit	1	TC
245-390	£441.00	TRIM KIT, vinyl & vinyl trim, black	1	TC
245-370	£441.00	TRIM KIT, vinyl & vinyl trim, green	1	TC
245-572	£441.00	TRIM KIT, vinyl & vinyl trim, honey tan	1	TC
245-360	£441.00	TRIM KIT, vinyl & vinyl trim, red	1	TC
245-570	£441.00	TRIM KIT, vinyl & vinyl trim, tan	1	TC
245-420	£441.00	TRIM KIT, vinyl & vinyl trim, biscuit	1	TD
245-430	£441.00	TRIM KIT, vinyl & vinyl trim, black	1	TD
245-410	£441.00	TRIM KIT, vinyl & vinyl trim, green	1	TD
245-582	£441.00	TRIM KIT, vinyl & vinyl trim, honey tan	1	TD
245-400	£441.00	TRIM KIT, vinyl & vinyl trim, red	1	TD
245-580	£441.00	TRIM KIT, vinyl & vinyl trim, tan	1	TD
245-460	£441.00	TRIM KIT, vinyl & vinyl trim, biscuit	1	TF
245-350	£525.00	TRIM KIT, vinyl & vinyl trim, black	1	TF
245-450	£441.00	TRIM KIT, vinyl & vinyl trim, green	1	TF
245-592	£441.00	TRIM KIT, vinyl & vinyl trim, honey tan	1	TF

iii. Part Number Price £ea. Description Req. Details

245-440	£441.00	TRIM KIT, vinyl panel & vinyl trim, red	1	TF
245-590	£441.00	TRIM KIT, vinyl panel & vinyl trim, tan	1	TF

Seat Assemblies & Cover Kits

Seat Assemblies

Our seat assemblies are the ideal option for those enthusiasts who need new seats but do not want to undertake re-trimming themselves. Our hand crafted leather covers are upholstered on to new timber frames, springs and padding by our specialist trimmers giving a beautifully finished seat assembly. Trimming T Type seats is a complicated job. These assemblies are ready to install, making them a simple and labour saving way to great seats in your T Type.

449-430	NCA	SEAT ASSEMBLY, leather, beige	1	TA-TB
449-425	NCA	SEAT ASSEMBLY, leather, green	1	TA-TB
449-435	£1,538.00	SEAT ASSEMBLY, leather, red	1	TA-TB
245-028	£1,328.00	SEAT ASSEMBLY, leather, biscuit	1	TC
245-038	£1,328.00	SEAT ASSEMBLY, leather, black	1	TC
245-018	£1,328.00	SEAT ASSEMBLY, leather, green	1	TC
245-458	£1,328.00	SEAT ASSEMBLY, leather, honey tan	1	TC
245-008	£1,328.00	SEAT ASSEMBLY, leather, red	1	TC
245-488	£1,328.00	SEAT ASSEMBLY, leather, tan	1	TC
245-068	£1,328.00	SEAT ASSEMBLY, leather, biscuit	1	TD
245-078	£1,328.00	SEAT ASSEMBLY, leather, black	1	TD
245-058	£1,328.00	SEAT ASSEMBLY, leather, green	1	TD
245-468	£1,328.00	SEAT ASSEMBLY, leather, honey tan	1	TD
245-048	£1,328.00	SEAT ASSEMBLY, leather, red	1	TD
245-498	£1,328.00	SEAT ASSEMBLY, leather, tan	1	TD
245-428	£2,300.00	SEAT ASSEMBLY, leather, biscuit	1	TF
245-448	£2,300.00	SEAT ASSEMBLY, leather, black	1	TF
245-418	£2,300.00	SEAT ASSEMBLY, leather, green	1	TF
245-478	£2,300.00	SEAT ASSEMBLY, leather, honey tan	1	TF
245-438	£2,300.00	SEAT ASSEMBLY, leather, red	1	TF
245-408	£2,300.00	SEAT ASSEMBLY, leather, tan	1	TF

Seat Cover Kits

Our seat cover kits are manufactured to the same exacting standards as all our T Type interior trim products. If you are re-trimming your seats we recommend replacing springs and foams to ensure a top quality finish.

449-520	£708.00	SEAT COVER KIT, leather, beige	1	TA-TB
449-515	£738.00	SEAT COVER KIT, leather, green	1	TA-TB
449-525	£708.00	SEAT COVER KIT, leather, red	1	TA-TB
245-020	£606.00	SEAT COVER KIT, leather, biscuit	1	TC
245-030	£606.00	SEAT COVER KIT, leather, black	1	TC
245-010	£606.00	SEAT COVER KIT, leather, green	1	TC
245-482	£606.00	SEAT COVER KIT, leather, honey tan	1	TC
245-000	£606.00	SEAT COVER KIT, leather, red	1	TC
245-480	£606.00	SEAT COVER KIT, leather, tan	1	TC
245-060	£606.00	SEAT COVER KIT, leather, biscuit	1	TD
245-070	£606.00	SEAT COVER KIT, leather, black	1	TD
245-050	£606.00	SEAT COVER KIT, leather, green	1	TD
245-492	£606.00	SEAT COVER KIT, leather, honey tan	1	TD
245-040	£606.00	SEAT COVER KIT, leather, red	1	TD
245-490	£606.00	SEAT COVER KIT, leather, tan	1	TD
245-100	£590.00	SEAT COVER KIT, leather, biscuit	1	TF
245-110	£590.00	SEAT COVER KIT, leather, black	1	TF
245-090	£590.00	SEAT COVER KIT, leather, green	1	TF
245-502	£590.00	SEAT COVER KIT, leather, honey tan	1	TF
245-080	£590.00	SEAT COVER KIT, leather, red	1	TF
245-500	£590.00	SEAT COVER KIT, leather, tan	1	TF

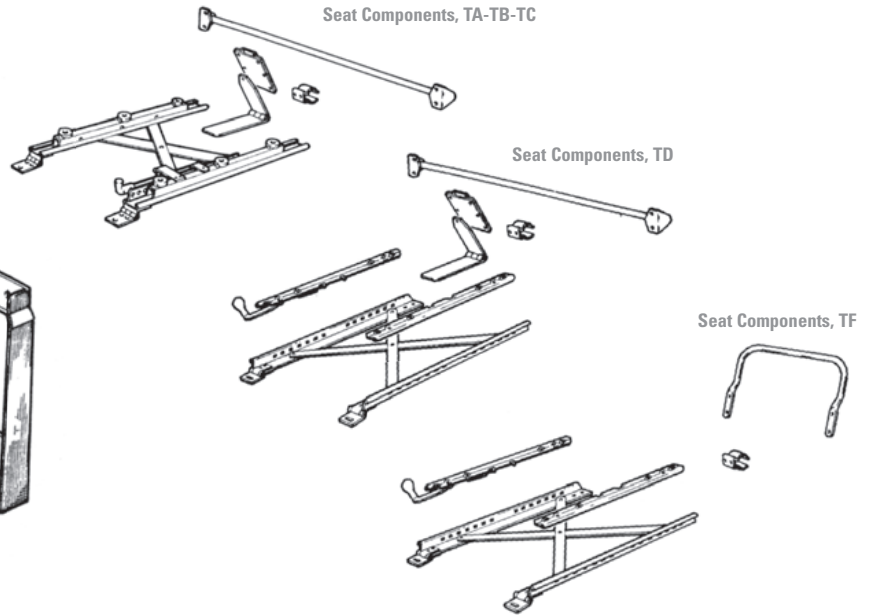
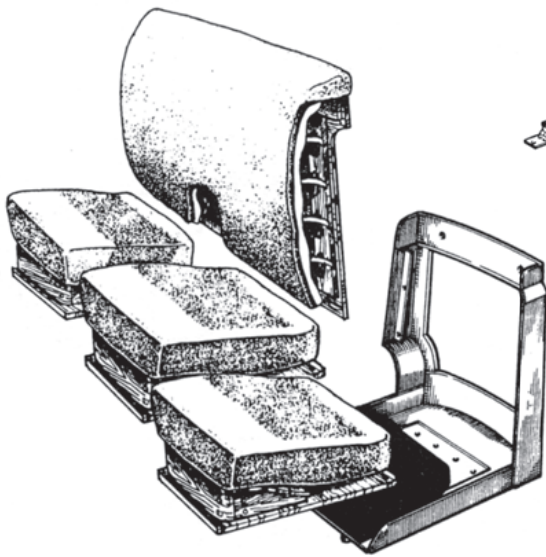

ill. Part Number Price £ea. Description Req. Details

Seat Frames & Components

Restore your interior to its original look and comfort. Even brand new upholstery won't look right if the foundation isn't up to par. These superb reproduction uncovered seat back and cushion assemblies are supplied complete with plywood bases, springs and foam padding as original.

TA- TC Seat Frames & Components

449-405	NCA	SQUAB & CUSHION SET	1	TA-TB
456-590	£399.50	SQUAB & CUSHION SET	1	TC
454-008	£352.80	SEAT SLIDE SET, RH/LH	1	
449-390	£41.00	TONNEAU BAR, top of seat back	1	TA-TB
451-750	£67.80	TONNEAU BAR, top of seat back	1	TC
406-070	£5.00	CLIP, starting handle storage	3	
406-080	£12.90	HINGE, seat back to cushion	2	
406-090	£14.35	SLEEVE, seat back hinge	2	

TD Seat Frames & Components

456-595	£399.50	SQUAB & CUSHION SET	1	
449-395	£89.20	SEAT SLIDE SET, RH/LH	1	
454-005	£48.40	SEAT SLIDE, LH	1	
454-015	£48.40	SEAT SLIDE, RH	1	
451-730	£60.80	TONNEAU BAR, top of seat back	1	
406-070	£5.00	CLIP, starting handle storage	3	
406-080	£12.90	HINGE, seat back to cushion	2	
406-090	£14.35	SLEEVE, seat back hinge	2	

TF Seat Frames & Components

456-615	£505.00	FRAME ASSEMBLY, RH	1	
456-605	£505.00	FRAME ASSEMBLY, LH	1	
456-635	£121.20	BASE & FOAM, RH	1	
456-625	£121.20	BASE & FOAM, LH	1	
456-645	£46.10	SPRING SET, seat squab	2	
454-028	£94.40	SEAT SLIDE SET, RH/LH	1	
453-195	£48.20	TONNEAU BAR, top of seat back	2	
406-070	£5.00	CLIP, starting handle storage	3	

Vinyl Material

Our standard colour vinyls are available per yard (91.4cm). The roll width is 52" (132cm). We will supply a continuous length as ordered.

456-315	£27.70	VINYL, red, per yard	a/r	
456-330	£26.70	VINYL, green, per yard	a/r	
456-415	£26.45	VINYL, black, per yard	a/r	
456-423	£26.40	VINYL, biscuit, per yard	a/r	
456-435	£28.50	VINYL, tan, per yard	a/r	

Note: Leather hides are also available in the above colours to special order. Please enquire at a branch.

ill. Part Number Price £ea. Description Req. Details

Carpet Kits, Mats & Boots

Our carpet kits are made to very exacting specifications - bound only where original and supplied with rubber heel mats. Carpet kits for TA-TB & TC include a leather handbrake boot, while TD & TF kits incorporate a leather gear shift boot. Rear deck areas were not carpeted originally but, are included in our TA-TD carpet kits

449-290	£216.40	CARPET KIT, black	1	TA-TB
449-310	NCA	CARPET KIT, red	1	
449-315	NCA	CARPET KIT, beige	1	
454-448	£124.30	CARPET KIT, black	1	TC
443-320	£124.30	CARPET KIT, red	1	
449-325	NCA	CARPET KIT, beige	1	
454-449	£124.30	CARPET KIT, honey tan	1	
454-060	£31.50	BOOT, handbrake lever	1	TA- TC
454-468	£136.70	CARPET KIT, black	1	TD
454-469	£136.70	CARPET KIT, honey tan	1	RHD flat floor
454-466	£136.70	CARPET KIT, red	1	
454-458	£168.00	CARPET KIT, black	1	TD to 4236
454-459	£168.00	CARPET KIT, honey tan	1	LHD
454-456	£168.00	CARPET KIT, red	1	
454-478	£168.00	CARPET KIT, black	1	TD from 4237
454-479	£168.00	CARPET KIT, honey tan	1	LHD
454-476	£168.00	CARPET KIT, red	1	
449-360	NCA	CARPET KIT, black	1	TF RHD
449-380	NCA	CARPET KIT, red	1	TF LHD
449-385	NCA	CARPET KIT, beige	1	without footwell mats
CRM2001X	£12.60	HEEL MAT, rubber	1	TD LHD To (c) 4256 & All TD RHD & TF RHD
280-400	£21.00	FOOTWELL MAT, rubber	1	TD LHD From (c) 4237 & TF With MG Motif
454-070	£26.40	BOOT, handbrake lever	1	TD- TF

Carpet Fittings

Carpet To Floorboards

1	610624	£0.29	STUD, floor mounting	8
2	GHF400	£0.10	SCREW, for stud	8
3	14G8736	£0.35	SPIKED RING	8
4	CD23803	£0.80	FASTENER, for spiked ring	8

Carpet To Bulkhead

5	552650	£0.60	FASTENER, socket, 'Lift the Dot'	4
	552650Z	NCA	FASTENER, socket, 'Lift the Dot'	4 unbranded
6	552651	£0.42	CLINCH PLATE, 'Lift the Dot'	4
7	97H717	£1.00	PEG, 'Lift the Dot'	4
8	GHF206	£0.08	NUT, for peg	4
9	WL700101	£0.12	LOCK WASHER, for nut	4

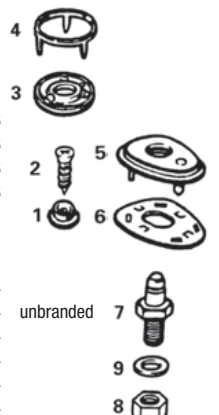



iii. Part Number Price £ea. Description Req. Details

T Type Hoods

TA's-TB's, and early TC's were originally trimmed in black Duck, a heavy single-ply canvas. Later TC's and TD's were trimmed in the same material but with a Tan duck which was light khaki Tan colour with a greenish cast to it. This material was known for its stiffness and its tendency to fading in bright light. TF's were originally trimmed in a multi-ply canvas material, which was light Tan with a pinkish cast to it. As both of these materials are now obsolete we now supply our weather equipment in our best double duck, which is a 2 ply with a membrane of rubber between layers for waterproofing.

As the listings indicate, we offer a full range of hood and tonneau covers. We do not install the hardware so that you can match the existing stud placement on your car. Although installation instructions are not included with our soft trim, most people find the task quite straight forward. We recommend you seek professional advice if you encounter any installation difficulties.

Hood Frames & Rails

449-240	£226.30	HOOD FRAME	1	TA & TB
453-335	£226.00	HOOD FRAME, 2-bow	1	TC
453-345	£215.90	HOOD FRAME, 2-bow	1	TD
453-355	£257.20	HOOD FRAME, 3-bow	1	TD
453-365	£257.20	HOOD FRAME	1	TF
453-230	£78.80	HOOD RAIL WOOD OVER WINDSCREEN	1	TA-TB & TC
453-240	£78.80	HOOD RAIL WOOD OVER WINDSCREEN	1	TD & TF
446-055	£15.00	WEBBING, black	1	car set
446-060	£15.00	WEBBING, tan	1	car set
CCHP1	£15.00	HOOD FRAME PAINT*	1	

*Note: 12 ounce spray can, custom formulated to duplicate original colour.

Hood Kits

449-245	£400.00	HOOD KIT SPLIT WINDOW, duck, tan	1	TA & TB
449-250	£400.00	HOOD KIT SPLIT WINDOW, duck, black	1	TA & TB
	NCA	HOOD KIT SPLIT WINDOW, vinyl, black	1	TA & TB
241-905	£394.80	HOOD KIT SPLIT WINDOW, duck, tan	1	TC
241-915	£394.80	HOOD KIT SPLIT WINDOW, duck, black	1	TC
	NCA	HOOD KIT SPLIT WINDOW, vinyl, black	1	TC
241-970	£395.00	HOOD KIT SINGLE WINDOW, duck, tan	1	TC
241-950	£395.00	HOOD KIT SINGLE WINDOW, duck, black	1	TC
	NCA	HOOD KIT SINGLE WINDOW, vinyl, black	1	TC
242-070	£395.00	HOOD KIT 2-BOW, duck, tan	1	TD
242-050	£395.00	HOOD KIT 2-BOW, duck, black	1	TD
242-010	£385.00	HOOD KIT 2-BOW, vinyl, black	1	TD

iii. Part Number Price £ea. Description Req. Details

242-170	£395.00	HOOD KIT 3-BOW, duck, tan	1	TD
242-150	£395.00	HOOD KIT 3-BOW, duck, black	1	TD
242-110	£385.00	HOOD KIT 3-BOW, vinyl, black	1	TD
242-270	£395.00	HOOD KIT, duck, tan	1	TF
242-250	£395.00	HOOD KIT, duck, black	1	TF
242-210	£385.00	HOOD KIT, vinyl, black	1	TF

Tonneau Covers

449-255	£318.00	TONNEAU COVER, duck, tan	1	TA & TB, full cover
449-260	£318.00	TONNEAU COVER, duck, black	1	TA & TB, full cover
	NCA	TONNEAU COVER, vinyl, black	1	TA & TB, full cover
449-265		NCA TONNEAU COVER, duck, tan	1	TA & TB, 1/2 cover
449-270	£226.50	TONNEAU COVER, duck, black	1	TA & TB, 1/2 cover
	NCA	TONNEAU COVER, vinyl, black	1	TA & TB, 1/2 cover
241-150	£324.00	TONNEAU COVER, duck, tan	1	TC, full cover
241-140	£324.00	TONNEAU COVER, duck, black	1	TC, full cover
	NCA	TONNEAU COVER, vinyl, black	1	TC, full cover
241-155	£232.00	TONNEAU COVER, duck, tan	1	TC, 1/2 cover
241-145	£232.00	TONNEAU COVER, duck, black	1	TC, 1/2 cover
	NCA	TONNEAU COVER, vinyl, black	1	TC, 1/2 cover
241-250	£324.00	TONNEAU COVER, duck, tan	1	TD, full cover
241-240	£324.00	TONNEAU COVER, duck, black	1	TD, full cover
241-220	£324.00	TONNEAU COVER, vinyl, black	1	TD, full cover
241-255	£232.00	TONNEAU COVER, duck, tan	1	TD, 1/2 cover
241-245	£232.00	TONNEAU COVER, duck, black	1	TD, 1/2 cover
	NCA	TONNEAU COVER, vinyl, black	1	TD, 1/2 cover
241-350	£324.00	TONNEAU COVER, duck, tan	1	TF, full cover
241-340	£324.00	TONNEAU COVER, duck, black	1	TF, full cover
241-320	£324.00	TONNEAU COVER, vinyl, black	1	TF, full cover
241-355	£232.00	TONNEAU COVER, duck, tan	1	TF, 1/2 cover
241-345	£232.00	TONNEAU COVER, duck, black	1	TF, 1/2 cover
	NCA	TONNEAU COVER, vinyl, black	1	TF, 1/2 cover

Hood & Tonneau Fittings

97H717	£1.00	LIFT-THE-DOT PEG	a/r	
GHF206	£0.08	NUT FOR PEG	a/r	
WL700101	£0.12	LOCK WASHER FOR NUT	a/r	
552667	£0.90	SELF-TAPPING STUD	a/r	
LFS100S	£1.00	LIFT-THE-DOT SNAP & PLATE	a/r	4 prong
227-108	£0.97	BUTTON SNAP	a/r	
610624	£0.29	BUTTON SNAP STUD	a/r	

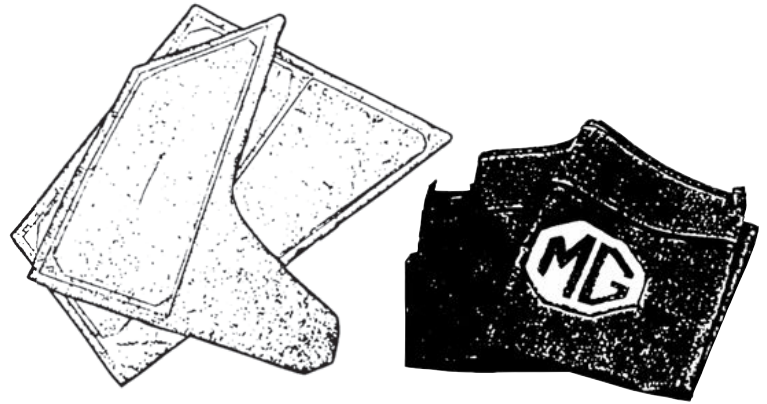
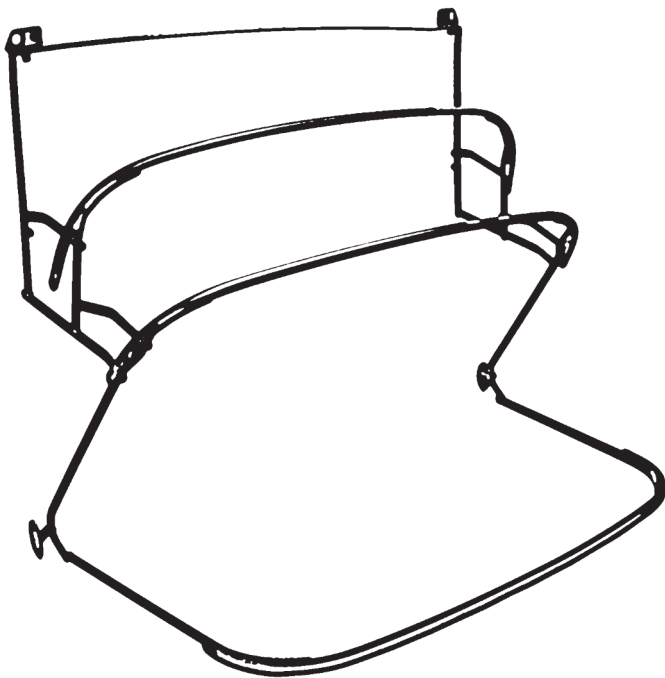

iii. Part Number Price £ea. Description Req. Details

Side Screen Covers & Frames

Our side screens duplicate exactly the size and fit of the original and, because they're crafted from the same material, they match our hood kits perfectly. The finishing strips supplied have spoon ends - which is correct for the TD and TF.

For TA-TB & TC owners that are die-hard purists or Concourse enthusiasts we offer a do-it-yourself mitre finishing strip kit. These kits include over-length strips which must be custom mitred to duplicate the original. Side screen frames are supplied in grey primer only, for the original beige paint, see inside back cover.

449-275	£394.80	COVERING KIT, duck, tan	1	TA & TB
449-280	£394.80	COVERING KIT, duck, black	1	TA & TB
449-285	£191.00	FRAME SET, 4 frames	1	TA & TB
252-508	NCA	STRIP KIT, with unfinished ends (Mitre for a perfect original-type fit).	1	TA & TB
252-008	£17.50	NUT & BOLT SET STRIP KIT, 63 of each	1	TA & TB
256-500	£395.00	COVERING KIT, duck, tan	1	TC
256-510	£395.00	COVERING KIT, duck, black	1	TC
253-100	£73.00	FRAME, front, left	1	TC
253-200	£73.00	FRAME, front, right	1	TC
253-300	£73.00	FRAME, rear, left	1	TC
253-400	£73.00	FRAME, rear, right	1	TC
252-108	£134.00	STRIP SET, with spoon ends	1	TC
252-508	NCA	STRIP KIT, with unfinished ends (All 16 strips need cutting to suit as they have mitred corners).	1	TC
252-008	£17.50	NUT & BOLT SET STRIP KIT, 63 of each	1	TC
256-600	£395.00	COVERING KIT, 2-Bows, duck, tan	1	TD
256-610	£395.00	COVERING KIT, 2-Bows, duck, black	1	TD
256-210	£385.00	COVERING KIT, 2-Bows, vinyl, black	1	TD
253-600	£73.00	FRAME, 2-Bows, front, left	1	TD
253-700	£73.00	FRAME, 2-Bows, front, right	1	TD
253-800	£73.00	FRAME, 2-Bows, rear, left	1	TD
253-900	£73.00	FRAME, 2-Bows, rear, right	1	TD
252-208	£134.00	STRIP KIT COMPLETE, 2-Bows	1	TD
252-018	£34.70	NUT & BOLT SET, 2-Bows, 58 of each	1	TD
256-700	£395.00	COVERING KIT, 3-Bows duck, tan	1	TD
256-710	£395.00	COVERING KIT, 3-Bows duck, black	1	TD
256-310	£385.00	COVERING KIT, 3-Bows vinyl, black	1	TD
254-100	£73.00	FRAME, 3-Bows, front, left	1	TD
254-200	£73.00	FRAME, 3-Bows, front, right	1	TD
254-300	£73.00	FRAME, 3-Bows, rear, left	1	TD
254-400	£73.00	FRAME, 3-Bows, rear, right	1	TD

iii. Part Number Price £ea. Description Req. Details

252-308	£134.00	STRIP KIT COMPLETE, 3-Bows	1	TD
252-018	£34.70	NUT & BOLT SET, 3-Bows, 58 of each	1	TD
256-800	£395.00	COVERING KIT, duck, tan	1	TF
256-810	£395.00	COVERING KIT, duck, black	1	TF
256-410	£385.00	COVERING KIT, vinyl, black	1	TF
254-600	£73.00	FRAME, front, left	1	TF
254-700	£73.00	FRAME, front, right	1	TF
254-800	£73.00	FRAME, rear, left	1	TF
254-900	£73.00	FRAME, rear, right	1	TF
252-408	£134.00	STRIP KIT COMPLETE	1	TF
252-018	£34.70	NUT & BOLT SET, 58 of each	1	TF

Side Screen Stowage Bag Set

Includes four custom tailored covers made from a soft yet sturdy cotton material, finished off with a large embroidered MG motif. All models.

259-808	£154.50	STOWAGE BAG SET	1	
---------	---------	-----------------	---	--

Side Screen & Tool Box Felt Kits

Felt sections to allow trimming of side screens and lining of the tool box.

456-448	£62.00	FELT KIT, side screens (Complete car set to re-trim all side screens).	1	
456-468	£63.50	FELT KIT, side screens (Complete car set to re-trim all side screens).	1	
456-420	£46.20	FELT KIT, tool box liner	1	

Threaded Fittings On MG 'T' Types

It's probably a good idea to explain the different thread forms employed on the hardware fitted to your car.

1 - 'Nuffield Metric'

This is the 'oddball' thread/hex head combination to be found on MPJG and XPAG/XPEG engines and gearboxes. When Morris took over the French Hotchkiss Plant at Coventry in 1923, they retained the continental metric tooling (presumably for reasons of cost). To make the situation more palatable for the Whitworth spanner wielding British public, Morris devised imperial hex head sizes for the metric hardware. This is why power unit production up to and including the T Type used such a strange, hybrid range of nuts, bolts and studs.

While the thread angle of the Nuffield metric form is the same as standard ISO metric thread (60°), the pitch is different; although you can hunt around and might find an old metric screw that fits your engine, it really is more worthwhile and less time consuming to purchase your engine hardware from us. An added bonus of taking the latter course is the peace of mind gained from knowing that our hardware is made from the correct material for the task!

2 - Whitworth

Conceived by Sir Joseph Whitworth in 1841, the range of Whitworth forms consists of four distinct types: British Standard Whitworth (BSW), British Standard Fine (BSF), British Standard Pipe (BSP) and British Standard Pipe Tapered (BSPT). On T Types, most body and chassis hardware is BSF, with a sprinkling of BSW. All pipe-work (oil, fuel and brake hydraulics) is BSP.

3 - British Association

A particularly fine thread form originally developed for clock and watch manufacture, "British Association" (BA) hardware is used in electrical components and generally wherever screws smaller than 1/4" BSF are required. Unlike other threads which are identified by their dimensions, the BA sizes range from 0BA to 16BA (the higher the number, the smaller the size). The most common automotive size is 2BA.

4 - Unified

A comparatively recent thread form, "Unified National Fine" (UNF) and "Unified National Coarse" (UNC) are only to be found on the running gear of late TD's & TF's (and just about everything on MGA's, MGB's).



Thread Restorer

For restoring damaged threads on bolts/studs.

- 386-600 THREAD RESTORER, (BSW/BSF) a/r
- 386-610 THREAD RESTORER, (metric) a/r

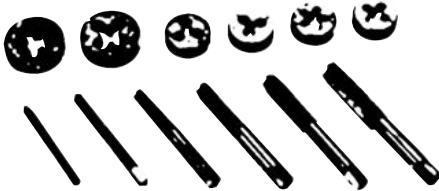

Taps & Dies

385-708	TAP & DIE SET (25 piece set, inc. all items listed below).	a/r
Taps		
5mm x 0.75mm	385-705	385-825
6mm x 1.0mm	385-710	385-830
8mm x 1.0mm	385-715	385-835
10mm x 1.5mm	385-720	385-840
12mm x 1.5mm	385-725	385-845
2BA 385-730	385-850	
1/4 BSF x 26	385-735	385-855
5/16 BSF x 22	385-740	385-860
Dies		

Taps & Dies (Continued)

	Taps	Dies
3/8 BSF x 20	385-745	385-865
7/16 BSF x 18	385-750	385-870
1/2 BSF x 16	385-755	385-875
Tap Spanner	385-700	
Die Holder, 1 5/16" stock	385-810	
Die Holder, 1" stock	385-820	

'Screw & Washer' and 'Bolt & Nut' Sets

323-818	Screw & Washer Set, floorboards	1	TA-TB & TC
323-828	Screw & Washer Set, floorboards	1	TD & TF1
323-838	Screw & Washer Set, dash, (8 each)	1	TA-TB & TC
323-848	Screw & Washer Set, dash, (8 each)	1	TD
321-778	Bolt & Nut Set, wing & running boards to body	1	TA-TB & TC
321-478	Bolt & Nut Set, instrument panel, dash, (8 of each)	1	TA-TB-TC&TD
321-758	Bolt & Nut Set, wing & running boards to body	1	TD
321-768	Bolt & Nut Set, wing & running boards to body	1	TF
323-778	Bolt & Nut Set, windscreen bracket to cowl, (6 screws & nuts)	1	TA-TB & TC
323-898	Bolt & Nut Set windscreen bracket to cowl, (8 screws & nuts)	1	TD & TF

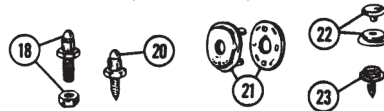

18	226-708	Stud & Nut, (1 stud & 1 nut)	a/r
20	552667	Stud, self-tapping	a/r
21	LFS100S	'Snap & Plate', 4-prong ('Lift the Dot')	a/r
22	227-108	Button Snap	a/r
23	610624	Stud, (button snap)	a/r

General Fasteners

Part No.	Item	Spanner Size	TPI	Dia.	Thread	Length
AJD6155Z	BOLT	3/16"	26	1/4"	BSF	5/8"
AJD6108Z	BOLT	3/16"	26	1/4"	BSF	1"
320-200	BOLT	3/16"	26	1/4"	BSF	1 1/4"
320-360	BOLT	1/4"	22	5/16"	BSF	3/4"
320-370	BOLT	1/4"	22	5/16"	BSF	1"
320-380	BOLT	1/4"	22	5/16"	BSF	1 1/4"
320-390	BOLT	1/4"	22	5/16"	BSF	1 1/2"
320-400	BOLT	1/4"	22	5/16"	BSF	1 3/4"
AJD6216Z	BOLT	1/4"	22	5/16"	BSF	2"
320-420	BOLT	1/4"	22	5/16"	BSF	2 1/2"
320-430	BOLT	1/4"	22	5/16"	BSF	2 3/4"
320-560	BOLT	5/16"	20	3/8"	BSF	3/4"
AJD6308Z	BOLT	5/16"	20	3/8"	BSF	1"
AJD6310Z	BOLT	5/16"	20	3/8"	BSF	1 1/4"
320-600	BOLT	5/16"	20	3/8"	BSF	1 1/2"
320-610	BOLT	5/16"	20	3/8"	BSF	2 1/2"
320-620	BOLT	5/16"	20	3/8"	BSF	2 3/4"
320-680	BOLT	3/8"	18	7/16"	BSF	1"
320-690	BOLT	3/8"	18	7/16"	BSF	2"
320-720	BOLT	7/16"	16	1/2"	BSF	1 3/4"
320-730	BOLT	7/16"	16	1/2"	BSF	2 1/2"
320-260	BOLT	1/4"	1mm	8mm	special metric	17mm
320-270	BOLT	1/4"	1mm	8mm	nyloc metric	21.5mm
320-290	BOLT	1/4"	1mm	8mm	nyloc metric	1"
AJD8012Z	NUT	1/8"	30	3/16"	2BA	
AJD8104	NUT	3/16"	26	1/4"	BSF	
AJD8105Z	NUT	1/4"	22	5/16"	BSF	
311-150**	NUT	1/4"	22	5/16"	BSF	
311-220	NUT	5/16"	20	3/8"	BSF	
311-240**	NUT	5/16"	20	3/8"	BSF	
311-280	NUT	3/8"	18	7/16"	BSF	
311-100	NUT	1/4"	1mm	8mm	special metric	
311-080**	NUT	13mm	1mm	8mm	metric nyloc	
311-190	NUT	17mm	1.5mm	10mm	special metric	

*Note: All spanner sizes refer to Whitworth and metric spanners.
**Note: Denotes self-locking hex nut.

Self Tapping Screws

Size	Length	Pan Head	Countersunk Head
No.4	1/4"	AB604021	AC604021
No.6	1/4"	AB606021	
No.6	3/8"	AB606031	
No.6	1/2"	AB606041	AC606041
No.6	3/4"	AB606061	AC606061
No.6	1"	AB606081	AC606081
No.8	1/2"	AB608041	AC608041
No.8	3/4"	AB608061	AC608061
No.8	1"	AB608081	
No.10	1/2"	AB610041	AC610041
No.10	3/4"	AB610061	AC610061
No.10	1"	AB610081	AC610081
No.12	1/2"	AB612041	AC612041
No.12	3/4"	AB612061	
No.12	1"	AB612081	AC612081
No.14	3/4"	AB614061	AC614061
No.14	1"	AB614081	AC614081

- B** = Pan Head
- C** = Countersunk Head
- 1st digit** = thread type (coarse or fine)
- 2nd/3rd digit** = diameter
- 4th/5th** = length in 1/8" increments
- 6th** = finish (1 = zinc plated)

Plain Brass - Manifold

(Full Nut) (Not used on T-Types, but what about your other classic?).

Part No.	Thread Size	Spanner Size
GHF261	5/16" UNF	1/2"
GHF262	3/8" UNF	9/16"
GHF270	5/16" UNC	1/2"
GHF269	3/8" UNC	9/16"

Spring/Spire Nut

Screw Size	Flat Type	'U' Type
No.6	GHF700	GHF711
No.8	GHF701	GHF712
No.10	GHF702	GHF713
No.12	GHF703	GHF714
No.14	GHF704	

Captive Nuts

Captive nuts consist of a square nut & cage which we supply individually as required. Always match nut & cage A.F. sizes.

Part No.	Description	Thread Size
NQ2707	Nut, 7/16" AF	1/4"
NQ2708	Nut, 5/8" AF	5/16"
CN4	Nut, fits CN3 cage	1/4"
CN5	Nut, /2" AF	5/16"

Part No.	Description	Spanner (AF) Size
CN2	Cage, square	7/16"
CN3	Cage, oblong	7/16"
600032	Cage, square	1/2"

Shake-proof Washers

Hole Size	Internal Star	External Star
No.6	WF704061	WE704061
3/16"	WF702101	WE702101
1/4"	WF600041	WE600041
5/16"	WF600051	WE600051
3/8"	WF600061	WE600061
7/16"	WF600071	WE600071
1/2"	WF600081	WE600081
9/16"	WF600091	WE600091
5/8"	WF600101	WE600101

Locking Washers Spring Type

Hole Size	Single Coil	Double Coil
No.6	WL700061	
No.8	WL700081	
3/16"	WL700101	AJD7721
1/4"	GHF331	AJD7722
5/16"	GHF332	AJD7731
3/8"	GHF333	AJD7742
7/16"	GHF334	
1/2"	GHF335	
5/8"	GHF336	

Plain Washers

Hole Size	Standard Type	Repair Type
No.6		WP3
No8		WP4
3/16"	GHF306	WP5
1/4"	GHF300	WP120
5/16"	GHF301	WP105
3/8"	GHF302	WP130
7/16"	GHF303	WM69
1/2"	GHF304	
9/16"		WP12
5/8"		PWZ110

Sealing Washers

Hole Size	Fibre Washer	Copper Washer
3/16"	WF505	
1/4"	GHF342	GHF361
5/16"	GHF343	GHF362
3/8"	GHF344	GHF363
7/16"	GHF345	GHF364
1/2"	GHF346	GHF365
9/16"	GHF347	
5/8"	GHF348	

Studs

A stud is a length of round bar threaded at both ends. The length of thread at each end of the stud may vary for specific applications. The following list is of studs have fine (UNF) threads at both ends.

Part No.	Dia.	Overall Length
TE604081	1/4"	1"
TE604091	1/4"	1 1/8"
TE604101	1/4"	1 1/4"
TE605101	5/16"	1 1/4"
TE605111	5/16"	1 3/8"
TE605121	5/16"	1 1/2"
TE605131	5/16"	1 5/8"
TE605141	5/16"	1 3/4"
TE605151	5/16"	1 7/8"
TE605181	5/16"	2 1/4"
TE605201	5/16"	2 1/2"
TE605221	5/16"	2 3/4"
TE605251	5/16"	3 1/8"
TE605291	5/16"	3 5/8"
TE606101	3/8"	1 1/4"
TE606111	3/8"	1 3/8"
TE606121	3/8"	1 1/2"
TE606141	3/8"	1 3/4"
TE606151	3/8"	1 7/8"

Note: The following studs have fine (UNF) threads at one end and course (UNC) at the other.

Part No.	Dia.	Overall Length
TE504081	1/4"	1"
TE504131	1/4"	1 5/8"
TE505091	5/16"	1 1/8"
TE505111	5/16"	1 3/8"
TE505121	5/16"	1 1/2"
TE505131	5/16"	1 5/8"
TE505141	5/16"	1 3/4"
TE505151	5/16"	1 7/8"
TE505161	5/16"	2"
TE505181	5/16"	2 1/4"
TE505201	5/16"	2 1/2"
TE505221	5/16"	2 3/4"
TE505241	5/16"	3"
TE505261	5/16"	3 1/4"
TE505271	5/16"	3 3/8"
TE505281	5/16"	3 1/2"
TE505341	5/16"	4 1/4"
TE506101	3/8"	1 5/16"
TE506131	3/8"	1 5/8"
TE506141	3/8"	1 3/4"
TE506161	3/8"	2"
TE506201	3/8"	2 1/2"
TE506361	3/8"	3 1/2"

Note: The following studs have course (UNC) threads at both ends.

Part No.	Dia.	Overall Length
101442	3/8"	1 5/8"
058688	3/8"	1 11/16"
115696	3/8"	1 1 3/16"
058917	3/8"	1 15/16"

Studs (Continued)

Part No.	Dia.	Overall Length
102474	3/8"	2 1/16"
107055	3/8"	2 3/8"

Dowels

Part No.	Dia.	Overall Length
DP204	1/8"	1/4"
DP205	1/8"	5/16"
DP306	3/16"	3/8"
DP407	1/4"	7/16"
DP408	1/4"	1/2"
DP410	1/4"	5/8"
DP411	1/4"	11/16"
DP414	1/4"	7/8"
DP508	5/16"	1/2"
DP514	5/16"	7/8"
DP608	3/8"	1/2"
DP619	3/8"	CTF

Clevis Pins

(Measured from under head to end).

Part No.	Length	Dia.
108326	1/2"	1/8"
PJ8504	3/8"	3/16"
CLZ307	7/16"	3/16"
CLZ308	1/2"	3/16"
CLZ309	9/16"	3/16"
CLZ310	5/8"	3/16"
CLZ311	11/16"	3/16"
CLZ312	3/4"	3/16"
CLZ313	1 3/16"	3/16"
CLZ314	7/8"	3/16"
CLZ315	15/16"	3/16"
CLZ316	1"	3/16"
CLZ317	1 1/16"	3/16"

CLZ408	1/2"	3/8"
CLZ409	9/16"	7/16"
CLZ410	5/8"	7/16"
CLZ411	11/16"	7/16"
CLZ412	3/4"	7/16"
CLZ413	13/16"	7/16"
CLZ414	7/8"	7/16"
CLZ415	15/16"	7/16"
CLZ416	1"	7/16"
CLZ417	1 1/16"	7/16"
CLZ427	1 11/16"	7/16"

CLZ510	1/2"	5/16"
CLZ511	9/16"	5/16"
CLZ512	5/8"	5/16"
CLZ513	11/16"	5/16"
CLZ514	3/4"	5/16"
CLZ515	13/16"	5/16"
CLZ516	7/8"	5/16"
CLZ517	15/16"	5/16"
CLZ518	1"	5/16"
	1 1/16"	5/16"
	1 1/8"	5/16"

Split Pins

Part No.	Length	Dia.
GHF500	1 1/2"	1/16"
GHF501	1 1/2"	5/64"
GHF502	1 1/2"	3/32"
GHF503	2 1/4"	7/64"
GHF504	2 1/4"	1/8"
GHF505	2 1/4"	9/64"
GHF506	2 1/4"	5/32"
GHF513	3"	5/16"

Brake & Fuel Pipe

Supplied in 25 foot rolls.

Part No.	Material	Dia.
MPKF125	Cupro-nickel	3/16"
MPKF225	Cupro-nickel	1/4"
MPKF325	Cupro-nickel	5/16"
EF125	Steel	3/16"
EF225	Steel	1/4"
EF325	Steel	5/16"

Pipe Nuts

Male, Steel

Part No.	Thread Size	Pipe Bore
TM606031	3/8" UNF	3/16"
TM110051	10mm x 1mm	3/16"
LK21994	3/8" BSF	3/16"
BCA4370	7/16" UNF	1/4"
BHA4706	7/16" UNF	3/16"
AUSU40A	1/2" UNF	5/16"

Male, Brass

Part No.	Thread Size	Pipe Bore
AEHU1	3/8" UNF	3/16"
AEHU2	10mm x 1mm	3/16"
AEHU3	3/8" BSF	3/16"
AEHU7	7/16" UNF	3/16"

Female, Steel

Part No.	Thread Size	Pipe Bore
TN606031	3/8" UNF	3/16"
SU2A	10mm x 1mm	3/16"
SU4A	7/16" UNF	1/4"
HU41A	1/2" UNF	5/16"

Female, Brass

Part No.	Thread Size	Pipe Bore
AEHU1A	3/8" UNF	3/16"
AEHU2A	10mm x 1mm	3/16"
AEHU4A	7/16" UNF	1/4"

Bleed Screws

Part No.	Thread Size
556508A	3/8" UNF
608400A	10mm metric
27H7166	3/8" BSF

Pipe Clips

Part No.	Capacity
GHF1191	SINGLE, 3/16"
GHF1192	SINGLE, 1/4"
624155	DOUBLE, 3/16"
	DOUBLE, 1/4"

Grease Nipples

Part No.	Thread Size	Angle
UHN400	1/8" BSP	straight, short
UHN445	1/8" BSP	450 angle
LN30041	1/8" BSP	900 angle
144825	1/8" BSP	straight, long
056935	1/4" BSP	straight
125361	1/4" BSP	450 angle
056934	1/4" BSP	900 angle

Petrol Pipe Clips, (Metric)

('Enots' type)

Part No.	to suit dia.
GGT1108X	8mm
GGT1109X	9mm
GGT1110X	10mm
GGT1111X	11mm
GGT1112X	12mm
GGT1113X	13mm
GGT1114X	14mm
GGT1115X	15mm
GGT1116X	16mm
GGT1117X	17mm

Hose Clips, ('Jubilee' type)

Mild Steel, (Imperial)

Part No.	to suit dia.
GHC304	3/8" - 1/2"
GHC405	7/16" - 5/8"
GHC406	1/2" - 3/4"
GHC507	5/8" - 7/8"
GHC608	3/4" - 1"
GHC709	5/8" - 1 1/8"
GHC811	1" - 1 3/8"
GHC913	1 1/8" - 1 5/8"
GHC1015	1 3/8" - 2"
GHC1217	1 1/2" - 2 1/4"
GHC1622	2" - 2 3/4"
GHC2228	2 3/4" - 3 1/2"
GHC2632	3 1/4" - 4"
GHC3036	3 3/4" - 4 1/2"
GHC3340	4 1/8" - 5"

Hose Clips**Stainless Steel, (Metric)**

Part No.	to suit dia.
GHC10408	8 - 12 mm
GHC10410	12 - 18 mm
GHC10411	8 - 16 mm
GHC10412	12 - 20 mm
GHC10413	16 - 25 mm
GHC10414	20 - 32 mm
GHC10415	25 - 40 mm
GHC10416	32 - 50 mm
GHC10417	46 - 60 mm
GHC10418	50 - 70 mm
GHC10419	60 - 80 mm
GHC10420	70 - 90 mm
GHC10421	80 - 100 mm

Hose Clips, ('Supergrip' type)

(With single slotted hexagon head)

Part No.	to suit dia.
CS4009	7/16" - 9/16"
CS4011	1/2" - 11/16"
CS4012	9/16" - 3/4"
CS4013	5/8" - 13/16"
CS4014	11/16" - 7/8"
CS4016	3/4" - 1"
CS4017	13/16" - 1 1/16"
CS4018	7/8" - 1 1/8"
CS4020	1" - 1 1/4"
CS4022	1 1/8" - 1 3/8"
CS4023	1 1/4" - 1 7/16"
CS4024	1 5/16" - 1 1/2"
CS4025	1 3/8" - 1 9/16"
CS4026	1 7/16" - 1 5/8"
CS4028	1 9/16" - 1 3/4"
CS4029	1 5/8" - 1 13/16"
CS4030	1 11/16" - 1 7/8"
CS4032	1 7/8" - 2"
CS4034	1 15/16" - 2 1/8"
CS4036	2 1/16" - 2 1/4"
CS4037	2 1/8" - 2 5/16"
CS4038	2 3/16" - 2 7/16"
CS4039	2 1/4" - 2 7/16"
CS4040	2 5/16" - 2 1/2"
CS4041	2 3/8" - 2 9/16"
CS4042	2 7/16" - 2 5/8"
CS4048	2 13/16" - 3"
CS4052	3 1/16" - 3 1/4"

Original "Supergrip" clips were supplied with a single slotted round-head screw. The modern replacement comes with a hexagon headed screw. For the authentic look we have resourced the original type screw, (sold separately).

CS4099, (round-head screw)

'P' Clips**Imperial**

Part No.	Cable Dia.	Hole Size
PCR207	1/8"	7/32"
PCR307	3/16"	7/32"
PCR309	3/16"	9/32"
PCR311	3/16"	11/32"
PCR407	1/4"	7/32"
PCR409	1/4"	9/32"
PCR411	1/4"	11/32"
PCR507	5/16"	7/32"
PCR509	5/16"	9/32"
PCR511	5/16"	11/32"
PCR607	3/8"	7/32"
PCR609	3/8"	9/32"
PCR611	3/8"	11/32"
PCR707	7/16"	7/32"
PCR709	7/16"	9/32"
PCR711	7/16"	11/32"
PCR807	1/2"	7/32"
PCR809	1/2"	9/32"
PCR811	1/2"	11/32"
PCR813	1/2"	13/32"
PCR1007	5/8"	7/32"
PCR1009	5/8"	9/32"
PCR1011	5/8"	11/32"
PCR1207	3/4"	7/32"
PCR1209	3/4"	9/32"
PCR1211	3/4"	11/32"

'P' Clips**Imperial**

Part No.	Cable Dia.	Hole Size
PCR1407	7/8"	7/32"
PCR1409	7/8"	9/32"
PCR1411	7/8"	11/32"
PCR1607	1"	7/32"

'P' Clips**Metric**

Part No.	Cable Dia.	Fixing Hole size
CP105081	8mm	5mm
PCR611	10mm	8mm
CP108121	12mm	8mm
CP106161	16mm	6mm
CP108165	16mm	8mm

Steel Balls

Part No.	Dia.
BLS106	3/16"
BLS108	1/4"
BLS110	5/16"
BLS112	3/8"
BLS28	7/16"

Pop Rivets**Open End Type**

Part No.	Dia.
RA607096	2.9 x 5mm
RA608126	1/8" x 3/16"
RA608176	1/8" x 1/4"
RA608236	1/8" x 5/16"
RA608253	1/8" x 3/8"

Pop Rivets**Closed End Type**

Part No.	Dia.
RU608123	1/8" x 3/8"
RU608313	1/8" x 1/2"
RU612123	3/16" x 5/16"

Cable Ties

Part No.	Length
GHF1265	3 1/2"
GHF1266	5 1/4"
RTC222A	6"
GHF1267	8 3/4"
GHF1268	11"



Paint and colour codes

Here is a list of the colours used on the MGT-Type. The colours are carefully blended to be an exact match to the original paint as used by the factory, but it is worth observing that your car may well have faded from its original colour over the years. For this reason before you start, we recommend that you do a test spray of any aerosol on a piece of old metal or a carefully selected area of the car where a mismatch will not be noticed.

We can supply paint in either aerosol and touch up (TU) format. For engine paint we can also supply paint in brush-on format (BR). The paint we supply is not for spray shop use. The aerosols come in 400ml cans and the brush-on paints are available in 125ml cans with a brush in the cap except for engine and chassis paints, which are supplied in 500ml tins).

Key to paint codes

Saxe Blue	Abingdon Blue	Trafalgar Blue	CCBU37 (TU)
-----------	---------------	----------------	-------------

The colour in the first column on the right are the paint colours applied to MGT-Type models during production (see example above).

- Saxe Blue - Is the factory listed T-Type colour name.
- Abingdon Blue - Is the alternative name.
- Trafalgar Blue - Is the classic car colour name.
- CCBU37 (TU) - Is the Moss paint code.
- (TU) - Means that a touch up option is available.
- (BR) - Means that a brush on option is available.
- Means that the colour was not available at the time of print and to contact Moss.

Saxe Blue is the factory listed T-Type colour name, Abingdon Blue is the alternative name, and Trafalgar Blue is the classic car colour name. It is available from Moss as an aerosol (part no. CCBU37) or as a touch up can (part no. CCBU37TU).

Trim colours

Moss supply trim for the MGT-TA, TB, TC and TF, from complete interior trim kits right through to replacement door trim panels. Moss can supply these in both leather and vinyl materials. The colours available were: Green (TA-TF), Beige (TA-TF), Red (TA-TF), and Tan (TF). Our interior trim kits are all made from original colour vinyls of correct specification mounted on accurately die cut boards. Much time and money has been invested in producing exact replacement parts including the tooling to produce original heat formed patterns. Please see the colour chart below or contact Moss Europe for full details.

	Green (TA-TF)
	Beige (TA-TF)
	Red (TA-TF)
	Tan (TF Only)

MG TA (1936-39)

Factory listed T-Type colour	Alternative names	Classic car colours name	Moss paint code
Saxe Blue	Abingdon Blue	Trafalgar Blue	CCBU37 (TU)
Racing Green	Dublin Green Emgee Green Apple Green	Racing Green	CCGN25 (TU)
Carmine Red	Emgee Red	Reno Red	CCRD14 (TU)
Black		Super Gloss Black	CCSB1 (TU)

MG TB (1939)

Saxe Blue	Abingdon Blue	Trafalgar Blue	CCBU37 (TU)
Coral Red	Emgee Red Carmine Red	Reno Red	CCRD14 (TU)
Apple Green	Dublin Green Emgee Green	Racing Green	CCGN25 (TU)
Duo Green		Willow Green Westminster Green	CCGN33 (TU) CCGN32 (TU)
Maroon		Embassy Maroon	CCRD21 (TU)
Metallic Grey		Regency Grey Metallic	CCGR14 (TU)
Black		Super Gloss Black	CCSB1 (TU)

MG TC (1945-49)

Red	MG Red Regency Red	Reno Red	CCRD14 (TU)
Green	Shires Green MG Green	Almond Green	CCGN37 (TU)
Cream	Sequoia Cream	Ivory	CCYL5 (TU)
Blue		Clipper Blue	CCBU14 (TU)
Black		Super Gloss Black	CCSB1 (TU)

MG TD (1949-53)

Black		Super Gloss Black	CCSB1 (TU)
MG Red		Reno Red	CCRD14 (TU)
Autumn Red		Autumn Red	CCRD6 (TU)
Almond Green		Almond Green	CCGN37 (TU)
Ivory		Ivory	CCYL5 (TU)
Clipper Blue		Clipper Blue	CCBU14 (TU)
Sun Bronze			Contact Moss
Woodland Green		British Racing Green (Dark)	CCGN29 (TU)
Silver Streak Grey Met.	Silver Streak Grey Met.		CCGR25 (TU)

MG TF (1953-55)

Black		Super Gloss Black	CCSB1 (TU)
MG Red		Reno Red	CCRD14 (TU)
Almond Green		Almond Green	CCGN37 (TU)
Ivory		Ivory	CCYL5 (TU)
Birch Grey		Birch Grey	CCGR3 (TU)
MG Green Metallic	MG Green Metallic		CCGN31 (TU)

To provide those (vital) final touches, the following colours are also available

Paint description	Colour names	Moss paint code
Engine Paint	Dark Green, (TA, TB, very early TC) Grey, (TC up to 1948) Dark Red, (TC 1948 on, TD, TF)	CCEP14 CCEP13 CCEP1
Wheel Paint	Silver, (Wire or Steel)	CCWP1
Chassis Paint	Black Enamel	CCCB1 (BR)
Hood/Side Screen Frames	Tan	CCHP1
Instrument Panel	Black, (TA, TB early TC)	CCSB1
	Bronze, (Later TC, TD, TF)	CCDP1

DYNOLITE

EUROPE'S CLASSIC MOTOR OIL

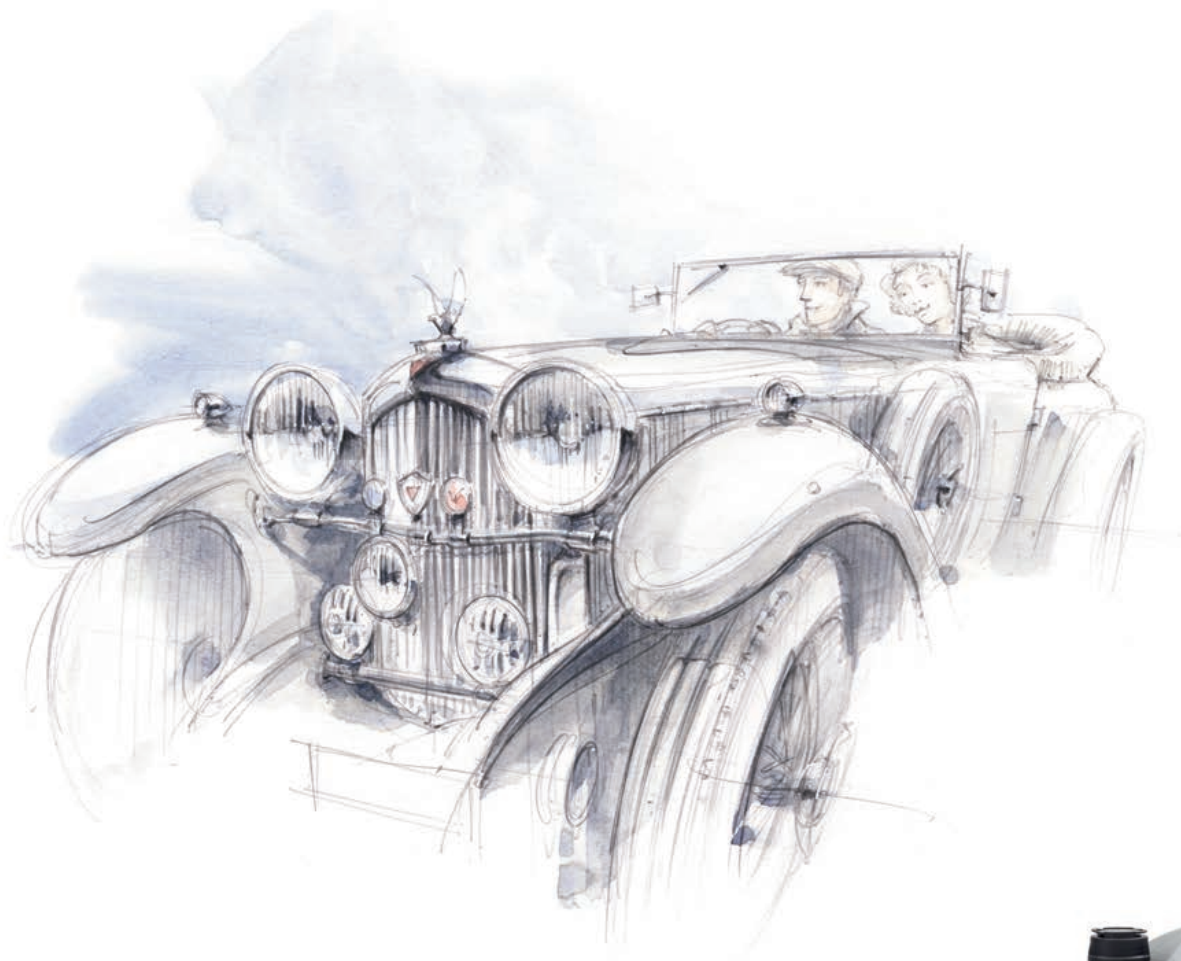

Dynolite Oil produces high quality oils and lubricants for vintage, classic and racing applications. Including lubricants for engines, gearboxes, steering boxes and greases. Dynolite lubricants are specially developed for historic vehicles to offer far superior mechanical protection.

www.dynolite.com

Dynolite Stockist: Moss Europe Ltd +44 (0)20 8867 2020



LONDON

LONDON

Unit 16, Hampton Business Park
Bolney Way, Feltham
TW13 6DB

London Tel
+44 (0) 20 8867 2020

E-mail
sales@moss-europe.co.uk

Fax
+44 (0) 20 8867 2030



BRADFORD

BRADFORD

Unit 12-13, Acorn Park Ind. Est.
Otley Road, Shipley
BD17 7SW

Bradford Tel
+44 (0) 1274 539 999

E-mail
bradford@moss-europe.co.uk

Fax
+44 (0) 1274 539 990



BRISTOL

BRISTOL

1-3 Elton Street
Bristol
BS2 9EH

Bristol Tel
+44 (0) 117 923 2523

E-mail
bristol@moss-europe.co.uk

Fax
+44 (0) 117 942 8236



MANCHESTER

MANCHESTER

111-117 Stockport Road
Stockport, Cheshire
SK3 0JE

Manchester Tel
+44 (0) 161 480 6402

E-mail
manchester@moss-europe.co.uk

Fax
+44 (0) 161 429 0349



PARIS MOTOR DREAM

PARIS

7 rue Chaponval
ZAC du Cornouiller
78870 Bailly, France

Paris Tel
+33 (0) 1 30 80 20 30

E-mail
sales@moss-europe.fr

Sav
+33 (0) 1 30 80 21 50

Moss Website
moss-europe.co.uk

 stores.ebay.co.uk/moss-europe-ltd

 Facebook
facebook.com/mosseurope

 Twitter
twitter.com/mosseurope

 Pinterest
pinterest.com/mosseurope

Moss Paris Website
moss-europe.fr